

# Catalogue

GB • Valid from 01.06.2018



**ESBE Made in Sweden since 1906**



**Hydronic system control units for your daily work**  
Product assortment overview with technical facts





# CONTENTS

**THE COMPANY**  
4-7

**1**

**ROTARY VALVES**  
40-66

**5**

**FAN COIL VALVES  
& ACTUATORS**  
96-100

**9**

**THERMOSTATIC  
MIXING VALVES**  
126-142

**13**



**CIRCULATION  
UNITS**  
8-27

**2**



**RETURN TEMPERATURE  
UNITS**  
28-35

**3**



**FRESH HYDRO  
UNITS**  
36-39

**4**



**ROTARY ACTUATORS**  
67-74

**6**



**CONTROLLERS**  
75-90

**7**



**ROOM THERMOSTATS**  
91-95

**8**



**SOLID FUEL  
PRODUCTS**  
101-111

**10**



**DIVERTING VALVES  
& ZONE VALVES**  
112-120

**11**



**THERMOSTATIC  
UNITS**  
121-125

**12**



**LINEAR  
VALVES**  
143-160

**14**



**LINEAR  
ACTUATORS**  
161-165

**15**



**COMPLEMENTARY  
PRODUCTS**  
166-171

**16**

**INDEX**  
172-174

**17**

**CERTIFICATES & PRODUCT  
DECLARATIONS**  
175

**18**









# SWEDISH EXPERTISE

**WHO WOULD YOU CONSULT ABOUT HEATING IF NOT A SWEDE?**

Living in Europe's most northerly corner our climate gives us reason to care about heating almost year round. And we know to appreciate it to both work reliably and not wasting any energy unnecessarily .

**ESBE is a truly Swedish company.** Our product development and manufacturing are still based in the small Swedish village of Reftele – where it all started. We are proud of the fact that Sweden and Swedish products have a good reputation all over the world. This inspires us in our daily business.

At the same time, ESBE has a local presence nowadays via our own colleagues and sales agents

around Europe, which are, of course, not all Swedish. But we are glad to have their help spreading the ESBE brand even further and with one common goal: to get more installers to discover the world of ESBE and choosing the right product for optimizing energy savings, comfort and safety.



# IT WORKS!

We continually and consistently move forward, and collaborate with our customers as well as with our suppliers. We have done so for 100 years – it's our way of working – and a tradition that we do not intend to break.

**For more than 100 years** we have been establishing new standards time after time for what valves and actuators can do in different systems. All our products have one or more of the following features in common: they use less energy, they enhance com-

fort and they improve safety; in systems for heating, cooling and tap water.

All the time in your daily work, installing valves and actuators, it is important that you can rely on the products you use. We can ensure you of this. It works!

<p><b>1906</b> In a small village named Reftele in Sweden, the company was founded.</p>	<p><b>1935</b> The first mixing valve. With trademark ESBE from day one.</p>	<p><b>1974</b> The first ESBE actuator.</p>	<p><b>1988</b> Compact mixing valves in brass set a new standard.</p>	<p><b>1991</b> Actuator series 60 revolutionize the market.</p>	<p><b>2001</b> The series VTA300 raise a new standard both for design and performance.</p>	<p><b>2003</b> Introducing the linear segment.</p>





**2007**

The brand new generation: valves VRG/VRB + actuator ARA600.



**2008**

VTC/LTC load valves completes the solid fuel segment.



**2010**

Controllers CRB/CRA bring ESBE even closer to the enduser.



**2014**

Increasing focus on system units.



**2015**

ESBE are the winner of the Red Dot Award: Product Design



**2018**

We look forward with excitement of what the future will bring to us and what we will be able to offer you.

# CIRCULATION UNITS SIZE DOESN'T MATTER

**ESBE offers a range of circulation units** developed specifically for the domestic market where few units serves a wide range of demands. All due to the built in 100 years of experience by ESBE in controlling and regulation of hydronic systems.







With Controller ready and mounted on the Circulation unit. Registered design.

GRC111      GRC112      GRC141      GRC142      GRC211      GRC212

## CIRCULATION UNIT

### Mixing function series GRC

- **Outstanding flow control thanks to the progressive characteristic of the valve**
- **Perfect heating curve characteristic**
- **High class insulation shell**
- **One size fit all – auto adapt + progressive characteristic**

The ESBE series GRC is a circulation mixing unit which is intended for heating circulations where outstanding flow and outside temperature control are required. Equipped with two shut-off valves with thermometers, check valve, high class isolation shell and high efficiency circulation pump. The GRC series is delivered with the 3-way rotary progressive mixing valve and actuator combined with controller. The Circulation Mixing Unit ensures best regulation performances independent from flow rate and low oversizing risk thanks to the progressive valve characteristic, as well the perfect heating curve characteristic.

#### TECHNICAL DATA

Pressure class: \_\_\_\_\_ PN 6  
 Media temperature: \_\_\_\_\_ max. +110°C  
 \_\_\_\_\_ min. 0°C  
 Ambient temperature, GRC100: \_\_\_\_\_ max. +50°C  
 GRC200: \_\_\_\_\_ max. +40°C  
 \_\_\_\_\_ min. 0°C  
 Working pressure: \_\_\_\_\_ 0,6 MPa (6 bar)  
 Connections: \_\_\_\_\_ Internal thread (G), ISO 228/1  
 \_\_\_\_\_ External thread (G), ISO 228/1  
 Insulation: \_\_\_\_\_ EPP λ 0,036 W/mK  
 Media: \_\_\_\_\_ Heating water (in accordance with VDI2035)  
 \_\_\_\_\_ Water / Glycol mixtures, max. 50%  
 (above 20% admixture, the pumping data must be checked)  
 \_\_\_\_\_ Water / Ethanol mixtures, max. 28%

Material, in contact with water:  
 Components of: \_\_\_\_\_ Brass, Cast iron, Steel  
 Sealing material of: \_\_\_\_\_ PTFE, Aramid fibre, EPDM

Conformities and certificates:  
 PED 2014/68/EU, article 4.3

CE LVD 2014/35/EU ErP 2009/125/EU  
 EMC 2014/30/EU ErP 2015  
 RoHS 2011/65/EU ErEV 2014

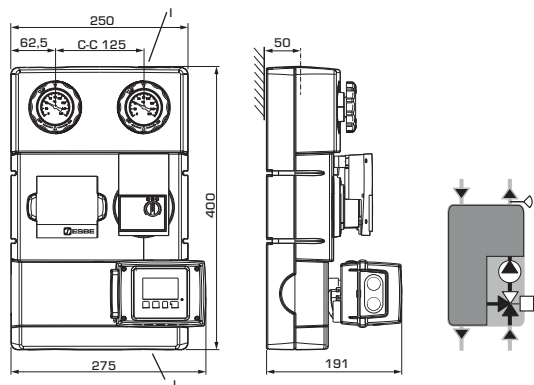

With Controller 90C-1A-90, weather compensated with pump control

Art. No.	Reference	DN	Pump	Connections		Weight [kg]	Note
				I	J		
61040300	GRC211	25	Wilo 25/6	G 1"	G 1½"	7,2	
61040800		32	Wilo 25/7,5	G 1¼"		7,9	
61041000	GRC212	25	Grundfos 25-50	G 1"	G 1½"	7,3	
61041200		32	Grundfos 25-70	G 1¼"		8,0	

SEE NEXT PAGE FOR MORE TABLES »



#### ADDITIONAL GUIDANCE

Accessories..... 19      Installation examples..... 25–26  
 Guide & Dimensioning..... 20      For further detailed information ..... [www.esbe.eu](http://www.esbe.eu)

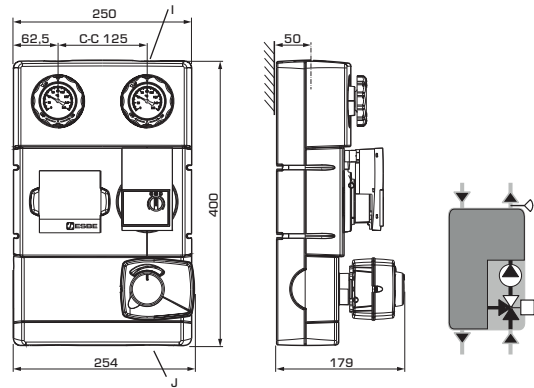

**CIRCULATION UNIT**  
Mixing function series GRC

With Controller CRD122, combined indoor and weather compensated

Art. No.	Reference	DN	Pump	Connections		Weight [kg]	Note
				I	J		
61041300	GRC141	25	Wilo 25/6	G 1"	G 1½"	7,0	With Room display unit
61041400		32	Wilo 25/7,5	G 1¼"		7,8	
61041500	GRC142	25	Grundfos 25-50	G 1"	G 1½"	7,1	
61041600		32	Grundfos 25-70	G 1¼"		7,9	

With Controller CRC111, weather compensated

Art. No.	Reference	DN	Pump	Connections		Weight [kg]	Note
				I	J		
61040200	GRC111	25	Wilo 25/6	G 1"	G 1½"	6,2	
61040700		32	Wilo 25/7,5	G 1¼"		7,0	
61040900	GRC112	25	Grundfos 25-50	G 1"	G 1½"	6,3	
61041100		32	Grundfos 25-70	G 1¼"		7,1	

With Actuator ready and mounted on the Circulation unit. Registered design.



**CIRCULATION UNIT**  
Mixing function series GRA

- **Outstanding flow control thanks to the progressive characteristic of the valve**
- **Ready to use with most controllers available on the market**
- **High class insulation shell**
- **One size fit all - auto adapt + progressive characteristic**

The ESBE series GRA is a circulation mixing unit which is intended for heating circulations where outstanding flow and temperature control are required. Equipped with two shut-off valves with thermometers, check valve, high class isolation shell and high efficiency circulation pump. The GRA series is delivered with a 3-way rotary progressive mixing valve and actuator. The Circulation Mixing Unit ensures best regulation performances independent from flow rate and low oversizing risk thanks to progressive valve characteristic, as well as the working possibility with most controllers available on the market.

Series GRA300 is in compact design with less outlet spacing than the others, and using a "Quick fit" connection between Valve and Actuator.

**TECHNICAL DATA**

Pressure class: \_\_\_\_\_ PN 6  
 Media temperature: \_\_\_\_\_ max. +110°C  
 \_\_\_\_\_ min. 0°C  
 Ambient temperature: \_\_\_\_\_ max. +50°C  
 \_\_\_\_\_ min. 0°C  
 Working pressure: \_\_\_\_\_ 0,6 MPa (6 bar)  
 Connections: \_\_\_\_\_ Internal thread (G), ISO 228/1  
 \_\_\_\_\_ External thread (G), ISO 228/1  
 Insulation: \_\_\_\_\_ EPP λ 0,036 W/mK  
 Media: \_\_\_\_\_ Heating water (in accordance with VDI2035)  
 \_\_\_\_\_ Water / Glycol mixtures, max. 50%  
 \_\_\_\_\_ (above 20% admixture, the pumping data must be checked)  
 \_\_\_\_\_ Water / Ethanol mixtures, max. 28%

Material, in contact with water:  
 Components of: \_\_\_\_\_ Brass, Cast iron, Steel  
 Sealing material of: \_\_\_\_\_ PTFE, Aramid fibre, EPDM

Conformities and certificates:  
 PED 2014/68/EU, article 4.3

LVD 2014/35/EU  
 EMC 2014/30/EU  
 RoHS 2011/65/EU  
 ErP 2009/125/EU  
 ErP 2015  
 EnEV 2014



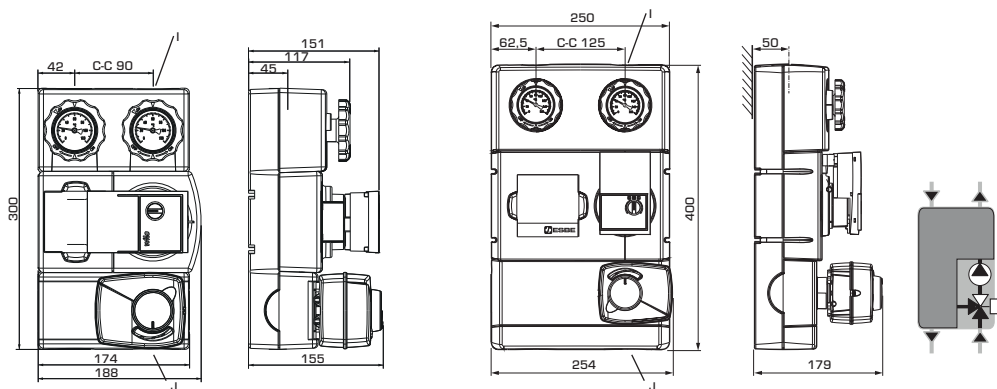

GRA311

GRA111, GRA112, GRA131, GRA132

**With Actuator ARA661, 230V 3-point**

Art. No.	Reference	DN	Pump	Outlet spacing [mm]	Connections		Weight [kg]	Note
					I	J		
61043100	GRA311	20	Wilo 15/7,5	90	G 3/4"	G 1"	4,5	
61040100	GRA111	25	Wilo 25/6	125	G 1"	G 1 1/2"	5,7	
61040400		32	Wilo 25/7,5		G 1 1/4"		6,4	
61040500	GRA112	25	Grundfos 25-50	125	G 1"	G 1 1/2"	5,8	
61040600		32	Grundfos 25-70		G 1 1/4"		6,5	

**With Actuator ARA639, 24V proportional/3-point**

Art. No.	Reference	DN	Pump	Outlet spacing [mm]	Connections		Weight [kg]	Note
					I	J		
61043200	GRA131	25	Wilo 25/6	125	G 1"	G 1 1/2"	5,7	
61043300		32	Wilo 25/7,5		G 1 1/4"		6,4	
61043400	GRA132	25	Grundfos 25-50	125	G 1"	G 1 1/2"	5,8	
61043500		32	Grundfos 25-70		G 1 1/4"		6,5	



**ADDITIONAL GUIDANCE**

Accessories..... 19  
 Guide & Dimensioning..... 20

Installation examples..... 25, 27  
 For further detailed information ..... [www.esbe.eu](http://www.esbe.eu)

Circulation unit intended for direct supply of heating. Registered design.



GDA311



GDA111



GDA112

**CIRCULATION UNIT**  
Direct supply series GDA

- High efficiency circulation pump
- High class insulation shell
- Pre tested and ready to use
- One size fit all – auto adapt function on board

The ESBE series GDA is a direct supply circulation unit designed for applications, where the energy transport in the most efficient way is required. Equipped with two shut-off valves with thermometers, check valve, high class isolation shell and high efficiency circulation pump. You can be sure that ESBE delivers the best circulation unit for both your economy as well as for the environment. It is simply the most efficient direct supply unit available. When designing the circulation unit product line the focus at ESBE has been to simplify installation. This goes through the whole product from pre assembly, mounting brackets and insulation to packaging design.

Series GDA300 is in compact design with less outlet spacing than the others.

**TECHNICAL DATA**

Pressure class: \_\_\_\_\_ PN 6  
 Media temperature: \_\_\_\_\_ max. +110°C  
 \_\_\_\_\_ min. 0°C  
 Ambient temperature: \_\_\_\_\_ max. +50°C  
 \_\_\_\_\_ min. 0°C  
 Working pressure: \_\_\_\_\_ 0,6 MPa (6 bar)  
 Connections: \_\_\_\_\_ Internal thread (G), ISO 228/1  
 \_\_\_\_\_ External thread (G), ISO 228/1  
 Insulation: \_\_\_\_\_ EPP λ 0,036 W/mK  
 Media: \_\_\_\_\_ Heating water (in accordance with VDI2035)  
 \_\_\_\_\_ Water / Glycol mixtures, max. 50%  
 (above 20% admixture, the pumping data must be checked)  
 \_\_\_\_\_ Water / Ethanol mixtures, max. 28%

Material, in contact with water:  
 Components of: \_\_\_\_\_ Brass, Cast iron, Steel  
 Sealing material of: \_\_\_\_\_ PTFE, Aramid fibre, EPDM

Conformities and certificates:  
 PED 2014/68/EU, article 4.3

CE LVD 2014/35/EU ErP 2009/125/EU  
 EMC 2014/30/EU ErP 2015  
 RoHS 2011/65/EU EnEV 2014

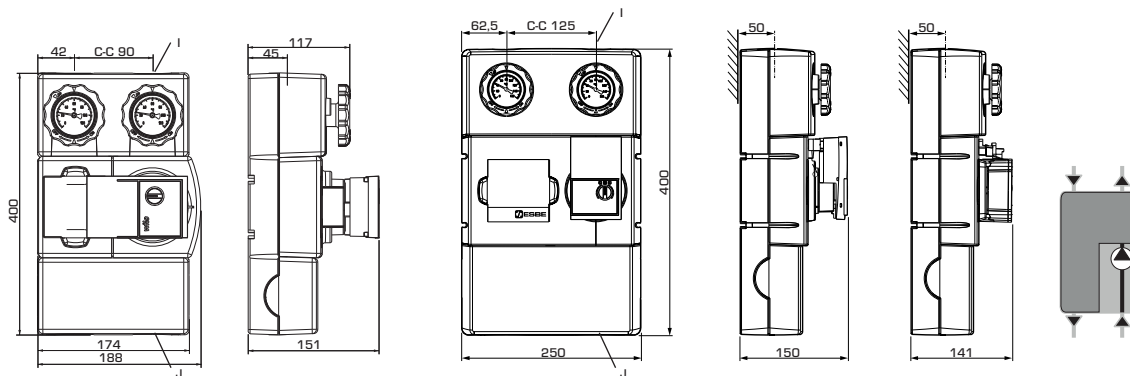

GDA311

GDA111, GDA112

Art. No.	Reference	DN	Pump	Outlet spacing [mm]	Connections		Weight [kg]	Note
					I	J		
61003100	GDA311	20	Wilo 15/7,5	90	G 3/4"	G 1"	3,7	
61000100	GDA111	25	Wilo 25/6	125	G 1"	G 1 1/2"	4,8	
61000200		32	Wilo 25/7,5		5,4			
61000300	GDA112	25	Grundfos 25-50	125	G 1"	G 1 1/2"	4,9	
61000400		32	Grundfos 25-70		5,5			



**ADDITIONAL GUIDANCE**

Accessories.....19  
 Guide & Dimensioning.....21

Installation examples.....25, 27  
 For further detailed information ..... [www.esbe.eu](http://www.esbe.eu)



Circulation unit intended for fixed temperature operation. Registered design.



GFA311

GFA111

GFA112

## CIRCULATION UNIT

### Fixed temperature series GFA

- **Thermostatic constant temperature control**
- **Adjustable temperature setting**
- **High class insulation shell**
- **High efficiency circulation pump**

The ESBE series GFA is a circulation mixing unit designed for heating circuits, where the constant temperature control is required. Equipped with two shut-off valves with thermometers, check valve, high class insulation shell and high efficiency circulation pump. The GFA series is delivered with the 3-way thermostatic mixing valve for constant temperature control of the heating circuit. The thermostatic mixing valve has adjustable temperature setting.

Series GFA300 is in compact design with less outlet spacing than the others.



#### TECHNICAL DATA

Pressure class: \_\_\_\_\_ PN 6  
 Media temperature: \_\_\_\_\_ max. +110°C  
 \_\_\_\_\_ min. 0°C  
 Ambient temperature: \_\_\_\_\_ max. +50°C  
 \_\_\_\_\_ min. 0°C  
 Working pressure: \_\_\_\_\_ 0,6 MPa (6 bar)  
 Connections: \_\_\_\_\_ Internal thread (G), ISO 228/1  
 \_\_\_\_\_ External thread (G), ISO 228/1  
 Insulation: \_\_\_\_\_ EPP λ 0,036 W/mK  
 Media: \_\_\_\_\_ Heating water (in accordance with VDI2035)  
 \_\_\_\_\_ Water / Glycol mixtures, max. 50%  
 (above 20% admixture, the pumping data must be checked)  
 \_\_\_\_\_ Water / Ethanol mixtures, max. 28%

Material, in contact with water:  
 Components of: \_\_\_\_\_ Brass, Cast iron, Steel  
 Sealing material of: \_\_\_\_\_ PTFE, Aramid fibre, EPDM

Conformities and certificates:  
 PED 2014/68/EU, article 4.3

 LVD 2014/35/EU  
 EMC 2014/30/EU  
 RoHS 2011/65/EU

 ErP 2009/125/EU  
 ErP 2015  
 EnEV 2014

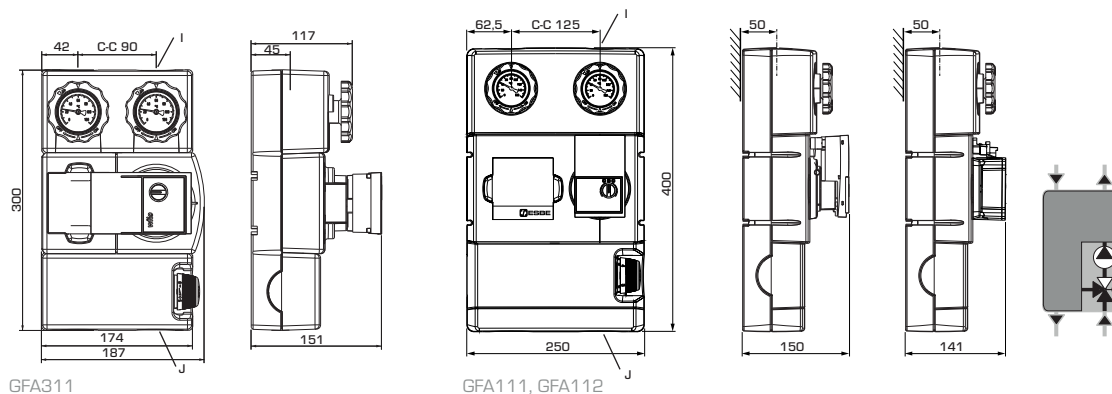

GFA311

GFA111, GFA112

Art. No.	Reference	DN	Pump	Outlet spacing [mm]	Temperature range	Connections		Weight [kg]	Note
						I	J		
61023100	GFA311	20	Wilo 15/7,5	90	20-55 °C	G 3/4"	G 1"	4,0	
61020100	GFA111	25	Wilo 25/6	125	20-55 °C	G 1"	G 1 1/2"	5,4	
61020200		32	Wilo 25/7,5			6,0			
61020300	GFA112	25	Grundfos 25-50	125	20-55 °C	G 1"	G 1 1/2"	5,5	
61020400		32	Grundfos 25-70			6,1			



#### ADDITIONAL GUIDANCE

Accessories.....19  
 Guide & Dimensioning.....22

Installation examples..... 25-27  
 For further detailed information ..... www.esbe.eu



GBC211



GBC212

With Controller ready and mounted on the Circulation unit. Registered design.

**CIRCULATION UNIT**  
 Bivalent mixing function series GBC

- **Efficient use of energy thanks to the bivalent valve**
- **Actuator combined with outside temperature controller**
- **System control**
- **One size fits all – auto adapt**

The ESBE series GBC is a circulation mixing unit which is intended for heating circulations where the outside temperature control and the efficient use of energy are required. Equipped with two shut-off valves with thermometers, check valve, high class isolation shell and high efficiency circulation pump. The GBC series is delivered with the bivalent rotary mixing valve and actuator combined with outside temperature controller. The Circulation Mixing Unit ensures efficient use of energy thanks to the bivalent rotary mixing valve, as well the system control thanks to the controller features.

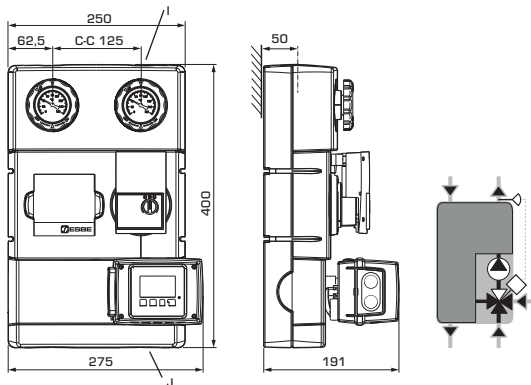

**With Controller 90C-3B-90, weather compensated**

Art. No.	Reference	DN	Pump	Connections		Weight [kg]	Note
				I	J		
61060200	GBC211	25	Wilo 25/6	G 1"	G 1½"	7,6	
61060400		32	Wilo 25/7,5	G 1¼"		8,3	
61060600	GBC212	25	Grundfos 25-50	G 1"	G 1½"	7,7	
61060800		32	Grundfos 25-70	G 1¼"		8,4	

**TECHNICAL DATA**

Pressure class: \_\_\_\_\_ PN 6  
 Media temperature: \_\_\_\_\_ max. +110°C  
 \_\_\_\_\_ min. 0°C  
 Ambient temperature: \_\_\_\_\_ max. +40°C  
 \_\_\_\_\_ min. 0°C  
 Working pressure: \_\_\_\_\_ 0,6 MPa (6 bar)  
 Connections: \_\_\_\_\_ Internal thread (G), ISO 228/1  
 \_\_\_\_\_ External thread (G), ISO 228/1  
 Insulation: \_\_\_\_\_ EPP λ 0,036 W/mK  
 Media: \_\_\_\_\_ Heating water (in accordance with VDI2035)  
 \_\_\_\_\_ Water / Glycol mixtures, max. 50%  
 (above 20% admixture, the pumping data must be checked)  
 \_\_\_\_\_ Water / Ethanol mixtures, max. 28%

Material, in contact with water: \_\_\_\_\_  
 Components of: \_\_\_\_\_ Brass, Cast iron, Steel  
 Sealing material of: \_\_\_\_\_ PTFE, Aramid fibre, EPDM

Conformities and certificates:  
 PED 2014/68/EU, article 4.3

- CE LVD 2014/35/EU
- EMC 2014/30/EU
- RoHS 2011/65/EU
- ErP 2009/125/EU
- ErP 2015
- EnEV 2014



**ADDITIONAL GUIDANCE**

- Accessories ..... 19
- Installation examples ..... 26
- Guide & Dimensioning ..... 23
- For further detailed information ..... [www.esbe.eu](http://www.esbe.eu)



With Actuator ready and mounted on the Circulation unit. Registered design.



GBA111



GBA112

## CIRCULATION UNIT

### Bivalent mixing function series GBA

- **Efficient use of energy thanks to the bivalent valve**
- **Ready to use with most controllers available on the market**
- **High class insulation shell**
- **One size fit all – auto adapt**

The ESBE series GBA is a circulation mixing unit which is intended for heating circulations where the flow temperature control and the efficient use of energy are required. Equipped with two shut-off valves with thermometers, check valve, high class isolation shell and high efficiency circulation pump. The GBA series is delivered with the bivalent rotary mixing valve and actuator. The Circulation Mixing Unit ensures efficient use of energy thanks to the bivalent rotary mixing valve, as well the working possibility with most controllers available on the market.

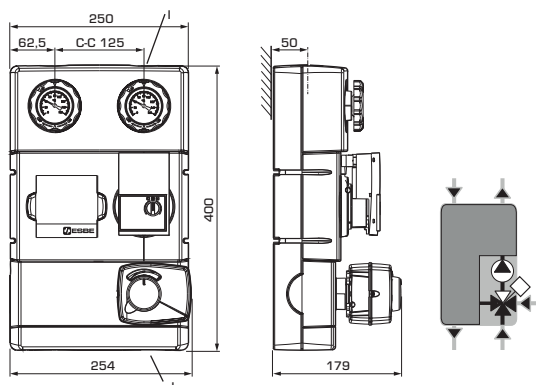

#### TECHNICAL DATA

Pressure class: \_\_\_\_\_ PN 6  
 Media temperature: \_\_\_\_\_ max. +110°C  
 \_\_\_\_\_ min. 0°C  
 Ambient temperature: \_\_\_\_\_ max. +50°C  
 \_\_\_\_\_ min. 0°C  
 Working pressure: \_\_\_\_\_ 0,6 MPa (6 bar)  
 Connections: \_\_\_\_\_ Internal thread (G), ISO 228/1  
 \_\_\_\_\_ External thread (G), ISO 228/1  
 Insulation: \_\_\_\_\_ EPP  $\lambda$  0,036 W/mK  
 Media: \_\_\_\_\_ Heating water (in accordance with VDI2035)  
 \_\_\_\_\_ Water / Glycol mixtures, max. 50%  
 (above 20% admixture, the pumping data must be checked)  
 \_\_\_\_\_ Water / Ethanol mixtures, max. 28%

Material, in contact with water:

Components of: \_\_\_\_\_ Brass, Cast iron, Steel  
 Sealing material of: \_\_\_\_\_ PTFE, Aramid fibre, EPDM

Conformities and certificates:

PED 2014/68/EU, article 4.3



LVD 2014/35/EU  
 EMC 2014/30/EU  
 RoHS 2011/65/EU



ErP 2009/125/EU  
 ErP 2015  
 EnEV 2014

#### With Actuator ARA661, 230V 3-point

Art. No.	Reference	DN	Pump	Connections		Weight [kg]	Note
				I	J		
61060100	GBA111	25	Wilo 25/6	G 1"	G 1½"	5,7	
61060300		32	Wilo 25/7,5	G 1¼"		6,4	
61060500	GBA112	25	Grundfos 25-50	G 1"	G 1½"	5,8	
61060700		32	Grundfos 25-70	G 1¼"		6,5	



#### ADDITIONAL GUIDANCE

Accessories ..... 19  
 Guide & Dimensioning ..... 23

Installation examples ..... 26  
 For further detailed information ..... [www.esbe.eu](http://www.esbe.eu)



GRF111



GRF121

Without pump and without/with Actuator ready and mounted on the Circulation unit. Registered design.

**CIRCULATION UNIT**  
Mixing function series GRF

- **Perfect control thanks to progressive valve characteristic**
- **180mm pump ready – be free to use favorite pump manufacturer**
- **Control the system manually, via actuator or even controller**
- **High class, adjustable insulation shell**

The ESBE series GRF100 is a circulation mixing unit which is intended for heating circulations where the flow and temperature control are required. Equipped with two shut-off valves with thermometers, check valve and high class isolation shell. The GRF100 is delivered with the 3-way rotary progressive mixing valve, which ensures low oversizing risk and best regulation performances independent from flow rate.

The ESBE Circulation Unit GRF100 is ready to work with 180mm pumps. The smart adjustable insulation shell makes it sure that any kind of pump will be isolated in a right way. Choose the best system control and select one of the actuators or controllers from ESBE program.

**TECHNICAL DATA**

Pressure class: \_\_\_\_\_ PN 6  
 Media temperature: \_\_\_\_\_ max. +110°C  
 \_\_\_\_\_ min. 0°C  
 Ambient temperature, GRF121: \_\_\_\_\_ max. +50°C / min. 0°C  
 GRF111: \_\_\_\_\_ max. °C / min. °C  
 (depends on the chosen electronic equipment)  
 Working pressure: \_\_\_\_\_ 0,6 MPa (6 bar)  
 Connections: \_\_\_\_\_ Internal thread (G), ISO 228/1  
 \_\_\_\_\_ External thread (G), ISO 228/1  
 Insulation: \_\_\_\_\_ EPP λ 0,036 W/mK  
 Media: \_\_\_\_\_ Heating water (in accordance with VDI2035)  
 \_\_\_\_\_ Water / Glycol mixtures, max. 50%  
 (above 20% admixture, the pumping data must be checked)

Material, in contact with water: \_\_\_\_\_  
 Components of: \_\_\_\_\_ Brass, Steel  
 Sealing material of: \_\_\_\_\_ PTFE, Aramid fibre, EPDM

Conformities and certificates:  
 PED 2014/68/EU, article 4.3

CE LVD 2014/35/EU  
 EMC 2014/30/EU  
 RoHS 2011/65/EU



EnEV 2014

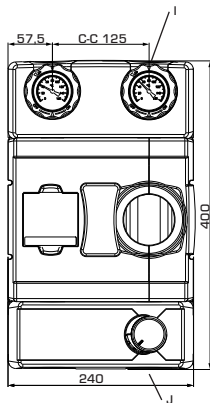

GRF111

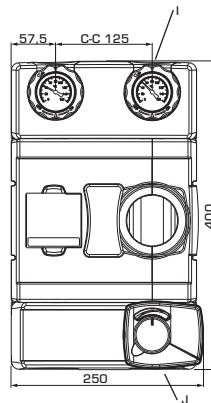
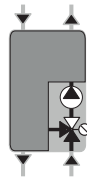
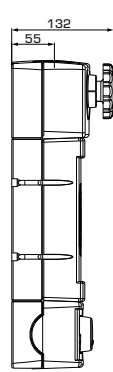

GRF121

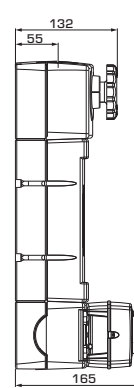

**With Actuator ARA661, 230 V 3-point**

Art. No.	Reference	DN	Connections		Weight [kg]	Note
			I	J		
61241100	GRF121	25	G 1"	G 1½"	4,2	

**Without Actuator**

Art. No.	Reference	DN	Connections		Weight [kg]	Note
			I	J		
61240100	GRF111	25	G 1"	G 1½"	3,8	



**ADDITIONAL GUIDANCE**

Accessories ..... 19  
 Guide & Dimensioning ..... 23

Installation examples ..... 27  
 For further detailed information ..... [www.esbe.eu](http://www.esbe.eu)



Circulation unit without pump intended for direct supply of heating. Registered design.

GDF111

## CIRCULATION UNIT

### Direct supply series GDF

- **180mm pump ready – be free to use favorite pump manufacturer**
- **High class, adjustable insulation shell**

The ESBE series GDF100 is a direct supply circulation unit designed for applications, where the energy transport is required. Equipped with two shut-off valves with thermometers, check valve and high class insulation shell.

The ESBE Circulation Unit GDF100 is ready to work with 180mm pumps. The smart adjustable insulation shell makes it sure that any kind of pump will be isolated in a right way.

#### TECHNICAL DATA

Pressure class: \_\_\_\_\_ PN 6  
 Media temperature: \_\_\_\_\_ max. +110°C  
 \_\_\_\_\_ min. 0°C  
 Ambient temperature: \_\_\_\_\_ max. °C / min. °C  
 (depends on the chosen electronic equipment)  
 Working pressure: \_\_\_\_\_ 0,6 MPa (6 bar)  
 Connections: \_\_\_\_\_ Internal thread (G), ISO 228/1  
 \_\_\_\_\_ External thread (G), ISO 228/1  
 Insulation: \_\_\_\_\_ EPP λ 0,036 W/mK  
 Media: \_\_\_\_\_ Heating water (in accordance with VDI2035)  
 \_\_\_\_\_ Water / Glycol mixtures, max. 50%  
 (above 20% admixture, the pumping data must be checked)

Material, in contact with water:  
 Components of: \_\_\_\_\_ Brass, Steel  
 Sealing material of: \_\_\_\_\_ PTFE, Aramid fibre, EPDM

Conformities and certificates:  
 PED 2014/68/EU, article 4.3



EnEV 2014

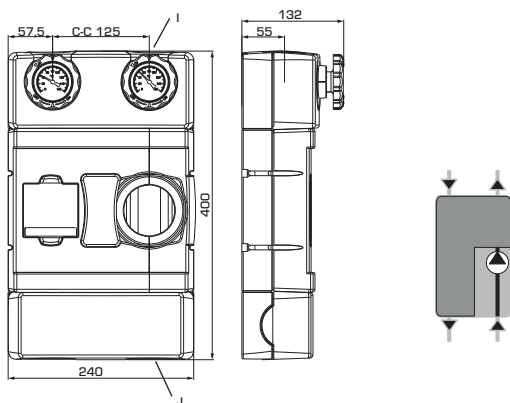

Art. No.	Reference	DN	Connections		Weight [kg]	Note
			I	J		
61200100	GDF111	25	G 1"	G 1½"	2,9	



#### ADDITIONAL GUIDANCE

Accessories.....	19	Installation examples.....	27
Guide & Dimensioning.....	23	For further detailed information .....	<a href="http://www.esbe.eu">www.esbe.eu</a>





Circulation unit without pump intended for fixed temperature operation. Registered design.

GFF111

**CIRCULATION UNIT**  
 Fixed temperature series GFF

- **Constant temperature control thanks to the thermostatic valve**
- **Adjustable flow temperature settings**
- **180mm pump ready – be free to use favorite pump manufacturer**
- **High class, adjustable insulation shell**

The ESBE series GFF100 is a circulation mixing unit which is intended for heating circulations where the constant temperature control are required. Equipped with two shut-off valves with thermometers, check valve and high class isolation shell. The GFF100 is delivered with the 3-way thermostatic valve, which provides constant temperature regulation of the heating system and adjustable temperature setting.

The ESBE Circulation Unit GFF100 is ready to work with 180mm pumps. The smart adjustable insulation shell makes it sure that any kind of pump will be isolated in a right way.

**TECHNICAL DATA**

Pressure class: \_\_\_\_\_ PN 6  
 Media temperature: \_\_\_\_\_ max. +95 °C  
 \_\_\_\_\_ min. 0 °C  
 Ambient temperature: \_\_\_\_\_ max. °C / min. °C  
 (depends on the chosen electronic equipment)  
 Working pressure: \_\_\_\_\_ 0,6 MPa (6 bar)  
 Connections: \_\_\_\_\_ Internal thread (G), ISO 228/1  
 \_\_\_\_\_ External thread (G), ISO 228/1  
 Insulation: \_\_\_\_\_ EPP λ 0,036 W/mK  
 Media: \_\_\_\_\_ Heating water (in accordance with VDI2035)  
 \_\_\_\_\_ Water / Glycol mixtures, max. 50%  
 (above 20% admixture, the pumping data must be checked)

Material, in contact with water:  
 Components of: \_\_\_\_\_ Brass, Steel  
 Sealing material of: \_\_\_\_\_ PTFE, Aramid fibre, EPDM

Conformities and certificates:  
 PED 2014/68/EU, article 4.3

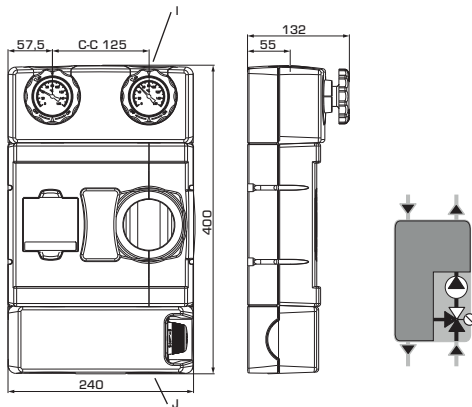

Art. No.	Reference	DN	Temperature range	Connections		Weight [kg]	Note
				I	J		
61220100	GFF111	25	20-55 °C	G 1"	G 1½"	3,8	



**ADDITIONAL GUIDANCE**

- Accessories ..... 19  
 Guide & Dimensioning ..... 23

- Installation examples ..... 27  
 For further detailed information ..... [www.esbe.eu](http://www.esbe.eu)



GMA321

GMA331



GMA121

GMA131

GMA221

GMA231

## MANIFOLD Series GMA

- **Insulation Fulfilling the EnEV2014 directive**
- **Easy installation with wall brackets included**
- **Reliable function and elegant look**

Series GMA120 is manifolds for 2 circulation units and Series GMA130 is manifolds for 3 circulation units including insulation according to EnEV2014 and wall brackets. Series GMA220 is manifolds for 2 circulation units and Series GMA230 is manifolds for 3 circulation units including integrated hydronic junction, insulation according to EnEV2014 and wall brackets.

The ESBE series GMA300 manifolds are dedicated for ESBE circulation units series GxA300. The manifolds have standard outlet dimension of 90mm and are equipped with insulation shell according to EnEV2014. The manifolds are delivered with wall brackets.

### TECHNICAL DATA

Pressure class: \_\_\_\_\_ PN 4  
 Media temperature: \_\_\_\_\_ max. +110°C  
 \_\_\_\_\_ min. 0°C  
 Working pressure: \_\_\_\_\_ 0,4 MPa (4 bar)  
 Flow rate: \_\_\_\_\_ 3,0 m<sup>3</sup>/h  
 Output: \_\_\_\_\_ 70 kW at Δt 20K

Material, in contact with water: \_\_\_\_\_  
 Components of: \_\_\_\_\_ Black coated steel S235  
 Insulation: \_\_\_\_\_ EPP λ 0,036 W/mK

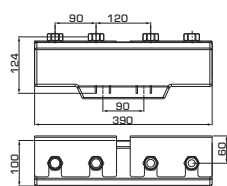

GMA321

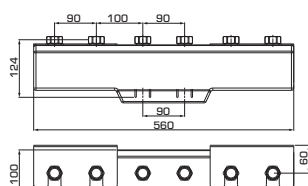

GMA331

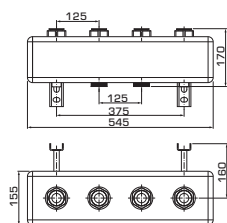

GMA121

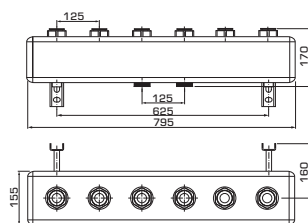

GMA131

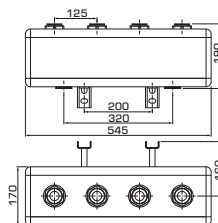

GMA221

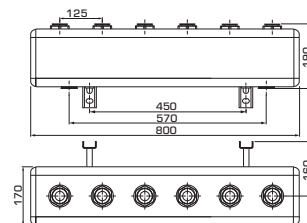

GMA231

Art. No.	Reference	No. of circulation units	Outlet spacing [mm]	Connections		With hydraulic separator	Weight [kg]	Note
				To system	From Heat source			
66000500	GMA321	2	90	RN 1" *	G 1"	No	3,1	
66000600	GMA331	3					No	4,5
66000100	GMA121	2	125	RN 1½" *	G 1½"	No	5,6	
66000200	GMA131	3					7,5	
66000300	GMA221	2				6,6		
66000400	GMA231	3				9,1		

\* RN = Rotating nut



### ADDITIONAL GUIDANCE

Guide & Dimensioning..... 24  
 Installation examples..... 25–27

For further detailed information ..... [www.esbe.eu](http://www.esbe.eu)

# CIRCULATION UNITS DIMENSIONING

Example: Start with the heating demand of heating circuit (e.g. 25 kW) and move horizontally to the right in the diagram to the  $\Delta t = 15^\circ\text{C}$  (temperature difference between flow and return of the heating circuit). Next go up and find working point and read the available pressure of the pump on the left -  $\Delta p = 45 \text{ kPa}$ .

**SERIES GRCx00, GRA100** - available pressure Wilo

Pump Capacity diagram

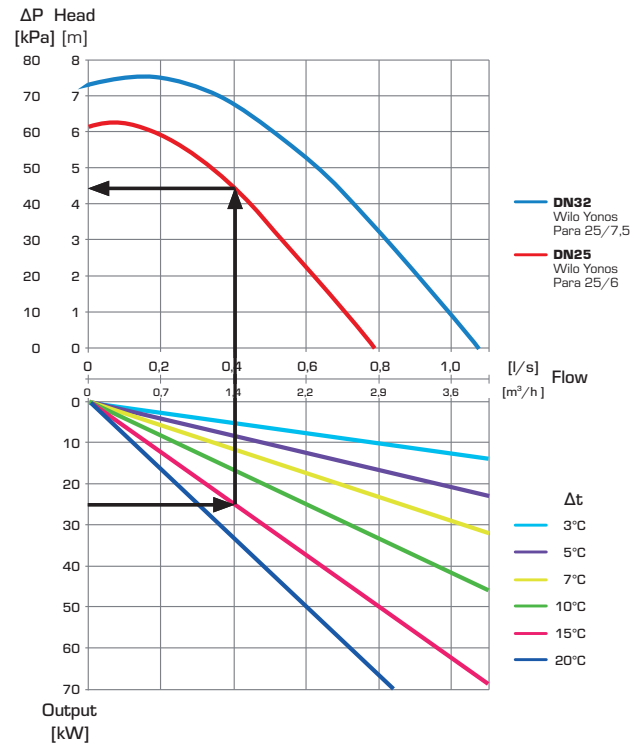

**SERIES GRA300** - constant speed

Pump Capacity diagram

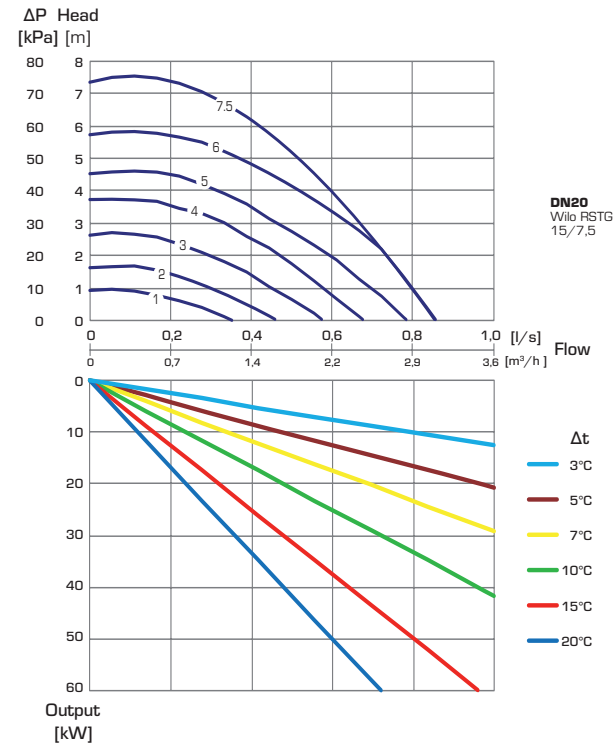

**SERIES GRCx00, GRA100** - available pressure Grundfos

Pump Capacity diagram

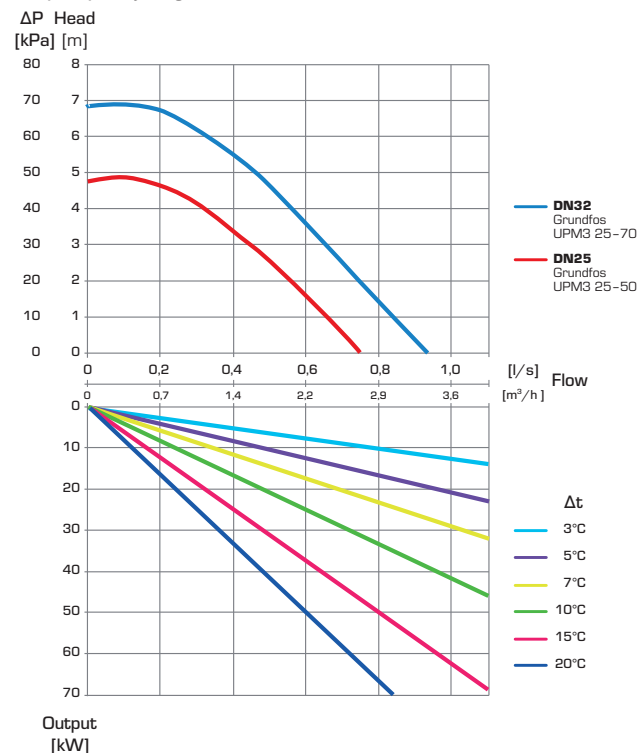

**SERIES GRA300** - variable pressure

Pump Capacity diagram

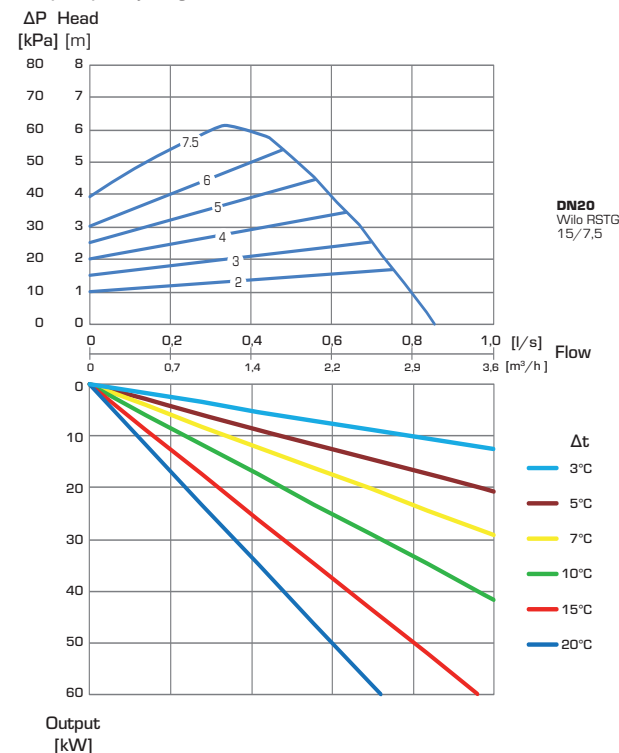



# CIRCULATION UNITS DIMENSIONING

## SERIES GDA100 – available pressure Wilo

Pump Capacity diagram

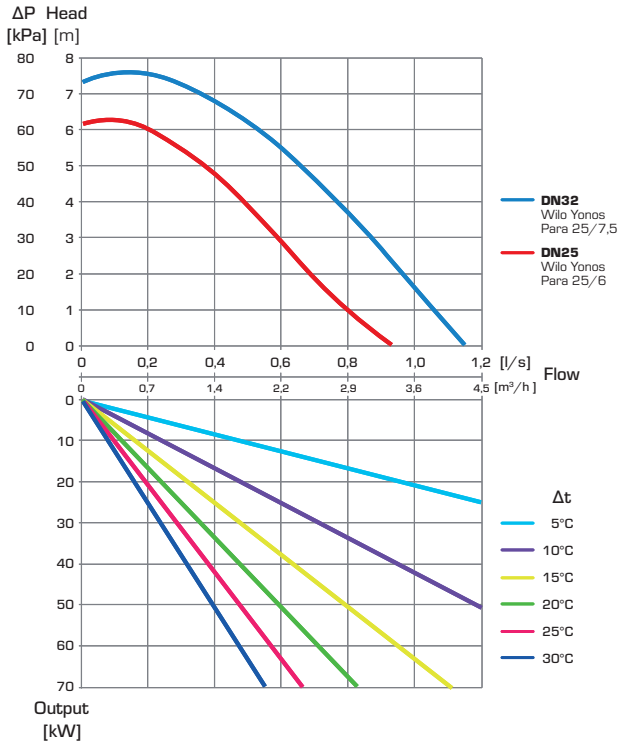

## SERIES GDA300 – constant speed

Pump Capacity diagram

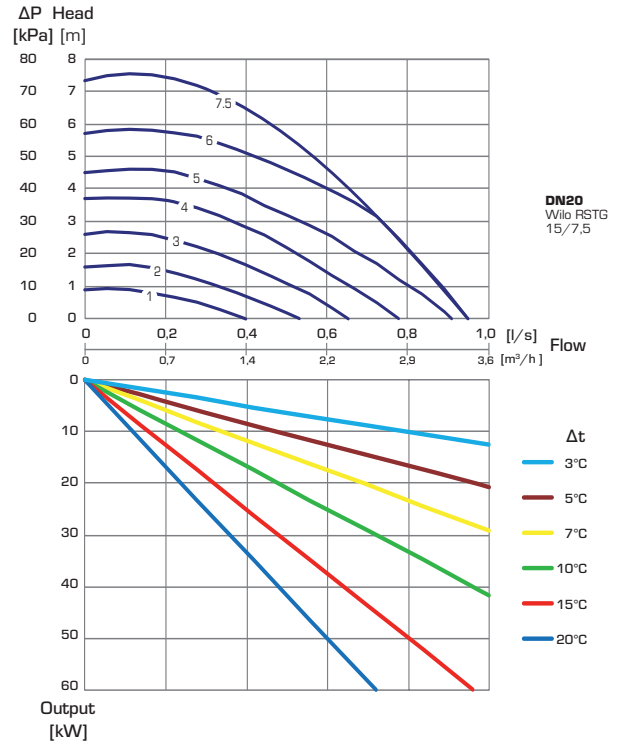

## SERIES GDA100 – available pressure Grundfos

Pump Capacity diagram

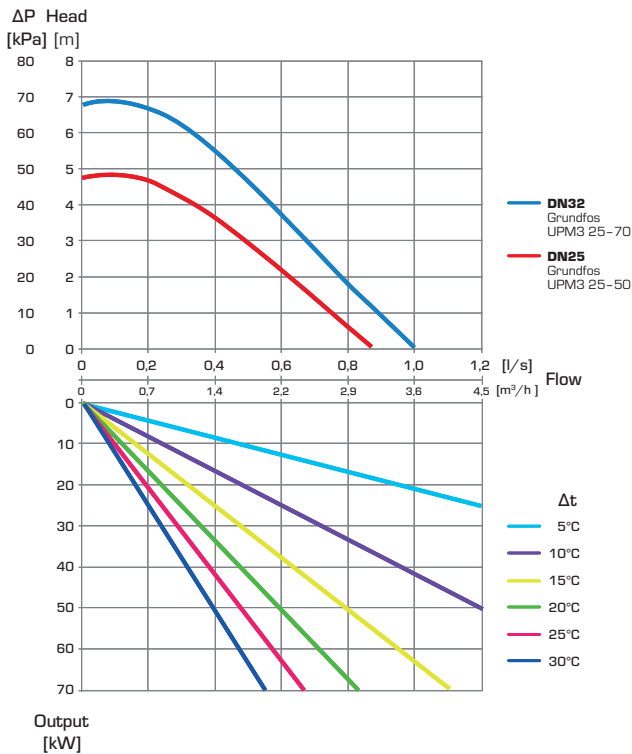

## SERIES GDA300 – variable pressure

Pump Capacity diagram

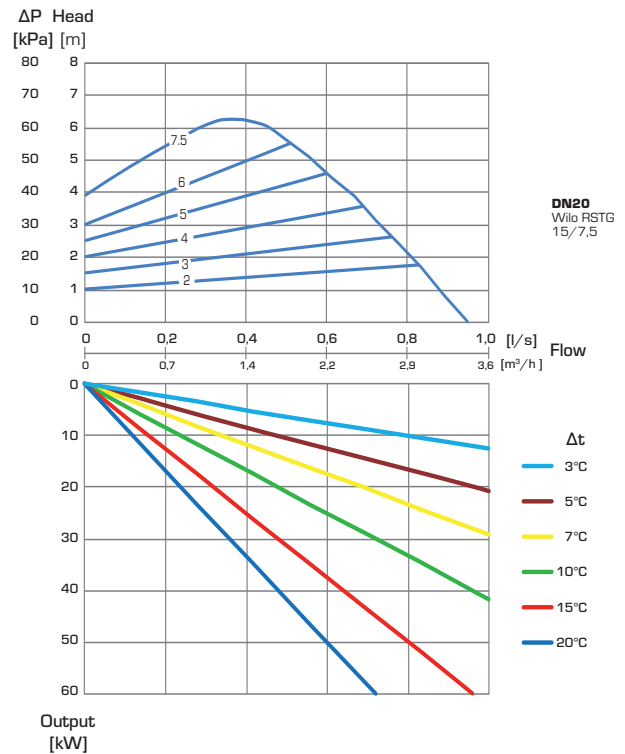

For further detailed information..... [www.esbe.eu](http://www.esbe.eu)

ESBE CATALOGUE • EN • A  
Valid from 01.06.2018

© Copyright. Rights reserved to make alterations.

# CIRCULATION UNITS DIMENSIONING

## SERIES GFA100 – available pressure Wilo

Pump Capacity diagram

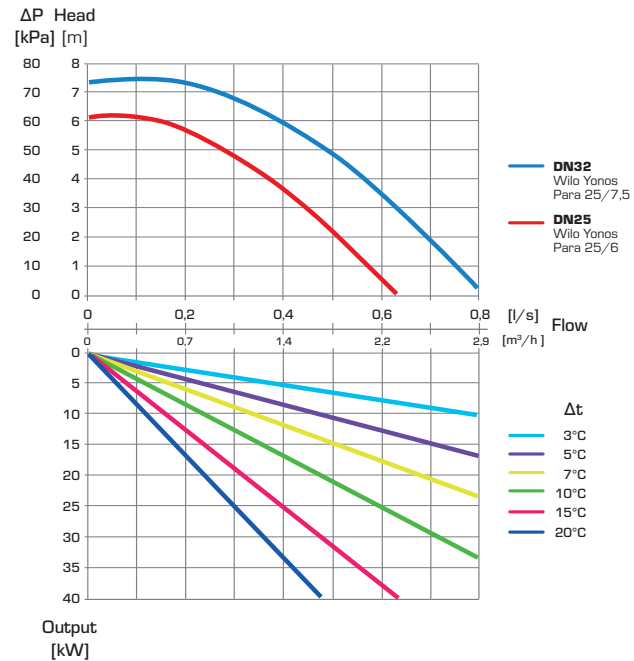

## SERIES GFA300 – constant speed

Pump Capacity diagram

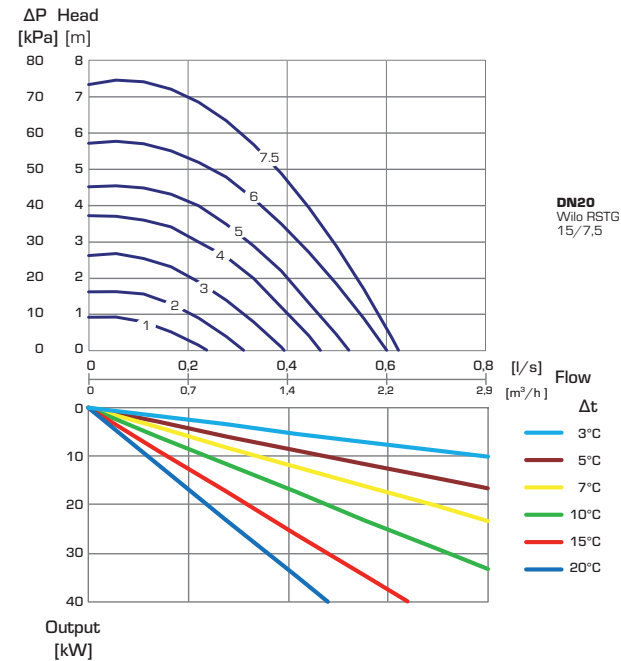

## SERIES GFA100 – available pressure Grundfos

Pump Capacity diagram

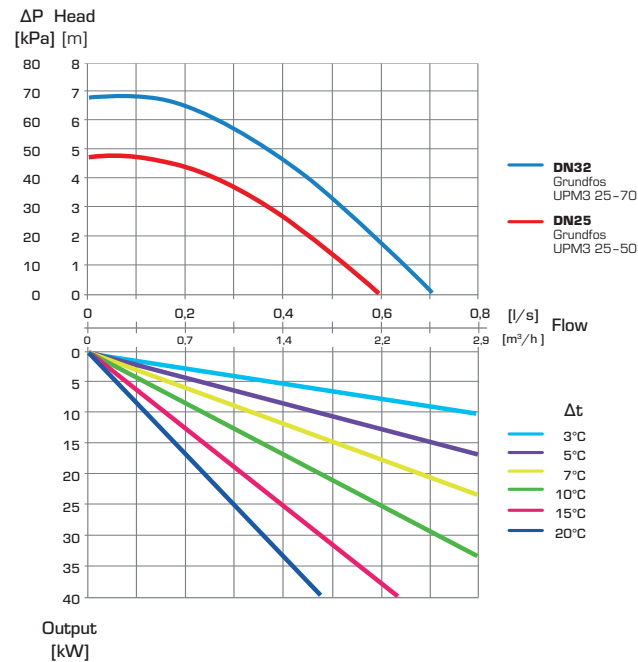

## SERIES GFA300 – variable pressure

Pump Capacity diagram

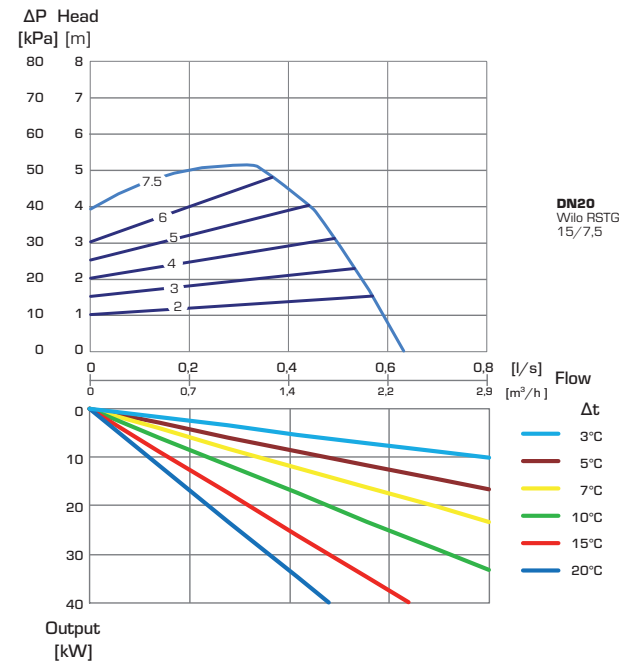

# CIRCULATION UNITS DIMENSIONING

## SERIES GBx – available pressure Wilo

### Pump Capacity diagram

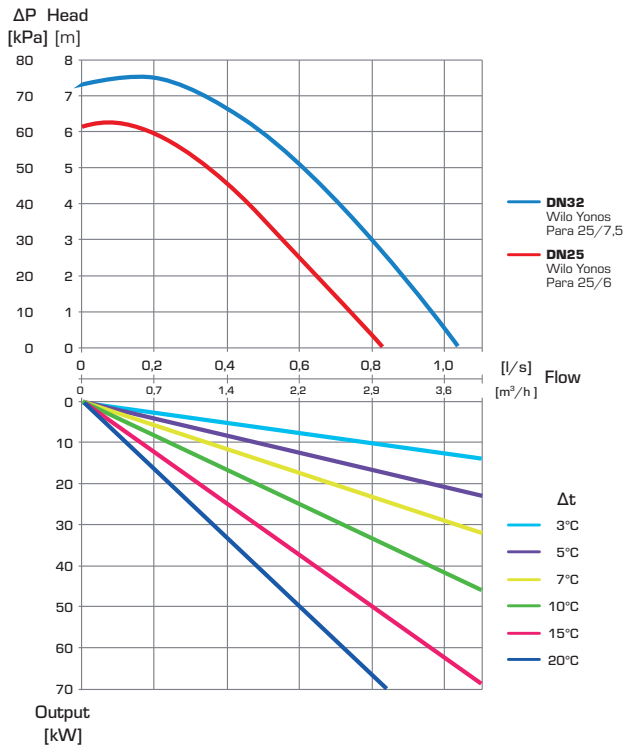

## SERIES GRF100 – Characteristics

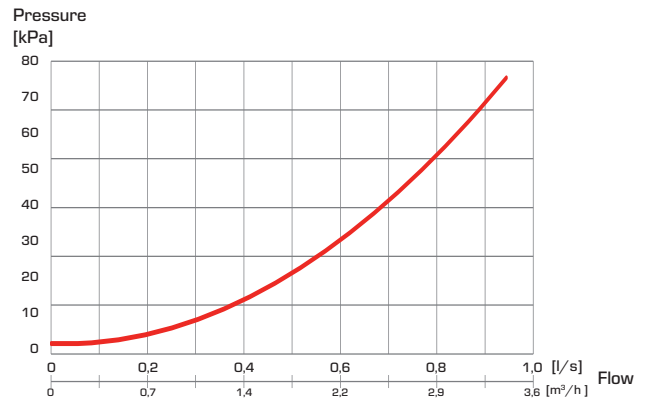

## SERIES GBx – available pressure Grundfos

### Pump Capacity diagram

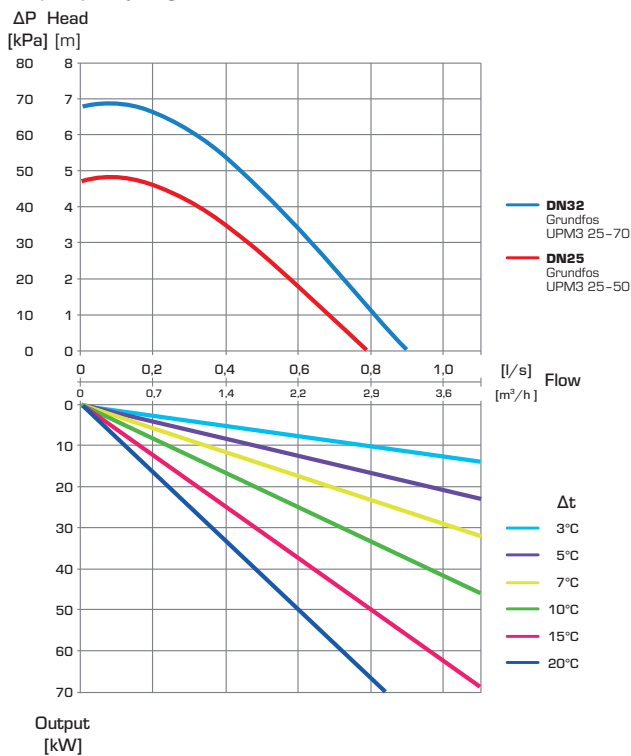

## SERIES GDF100 – Characteristics

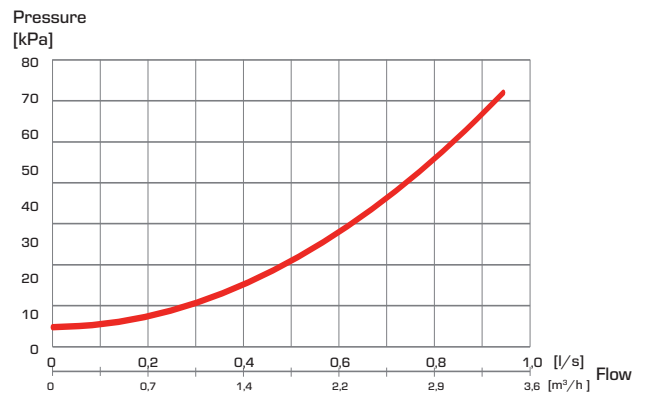

## SERIES GFF100 – Characteristics

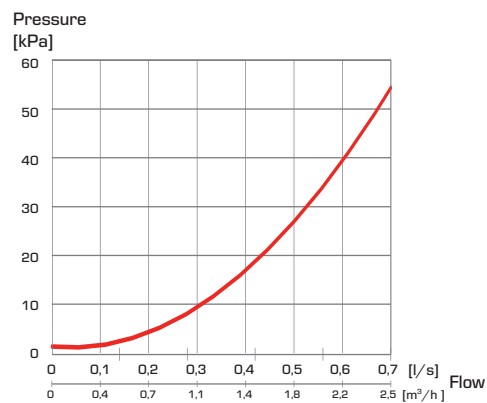

For further detailed information..... [www.esbe.eu](http://www.esbe.eu)



## MANIFOLDS DIMENSIONING

**Example:** Start with calculating flow capacity for each circulation unit which are simultaneously in operation by using the dimensioning diagrams for the circulation units. When flow has been summarized, move horizontally to the right in the diagram to the calculated flow, go vertically to the curve equal to the manifold representing the number of circulation units in operation and then go left and read the pressure drop of the manifold.

### SERIES GMA100, GMA200

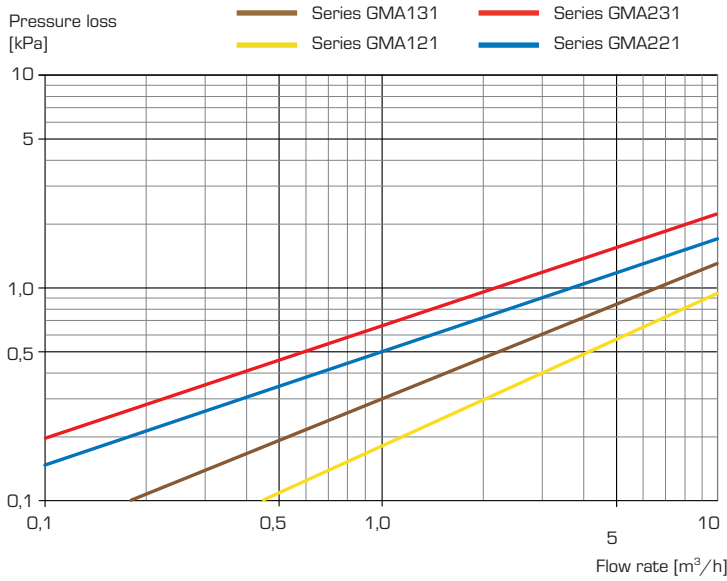

#### With or without an integrated hydraulic separator

The ESBE series GMA200 are manifolds with integrated hydraulic separator – to use when the heat source has an in-built circulator.

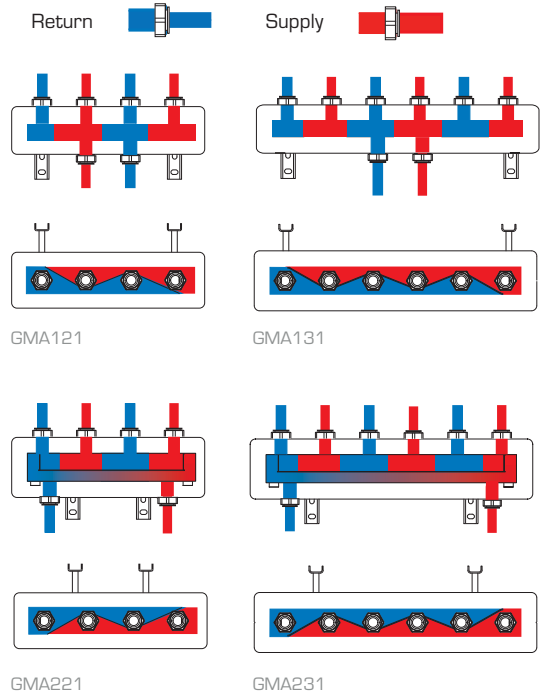

### SERIES GMA300

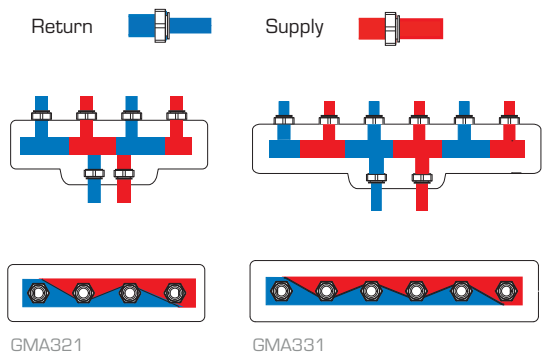
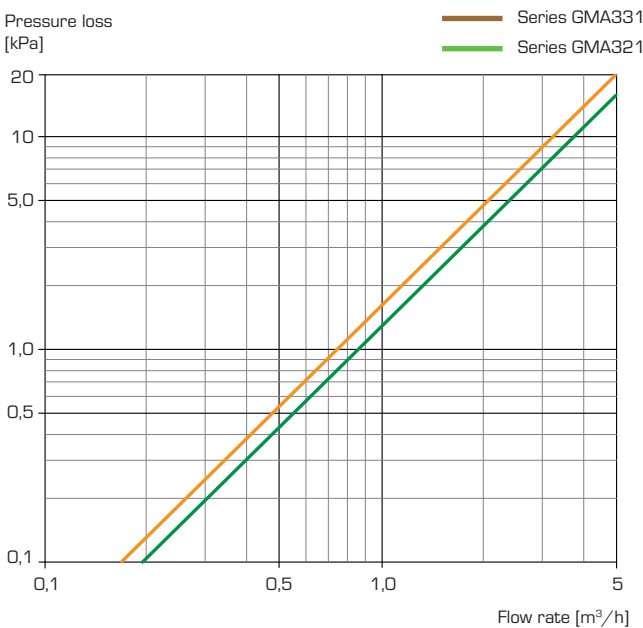

# CIRCULATION UNITS INSTALLATION EXAMPLES

1

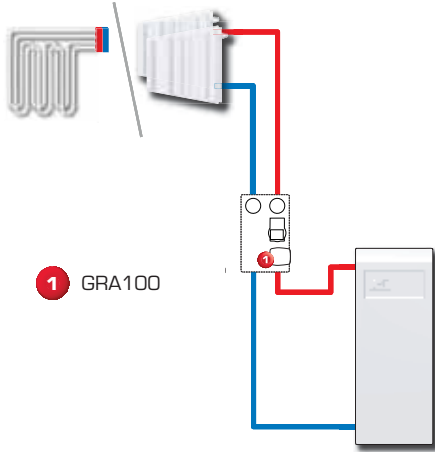

3

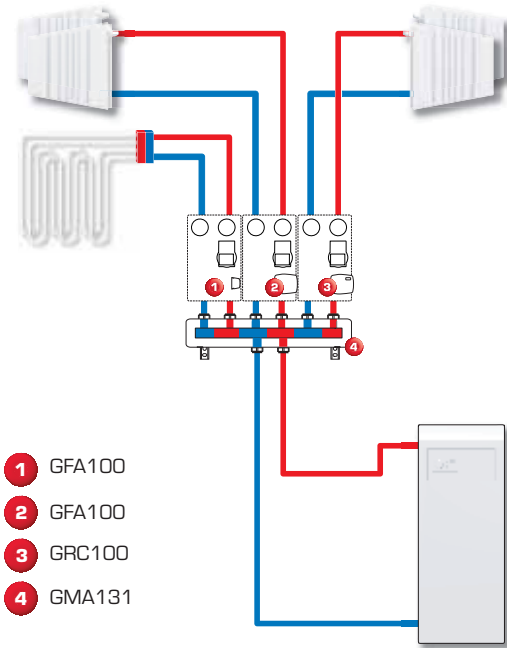

2

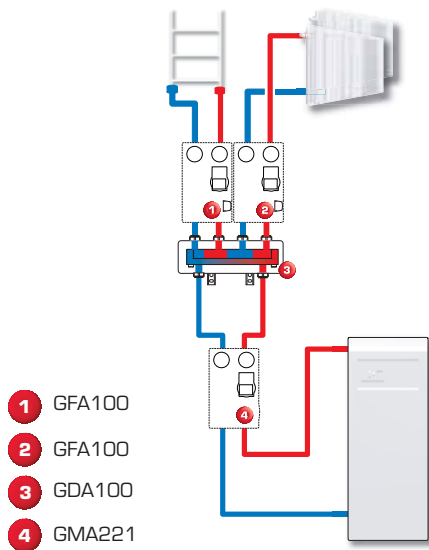

4

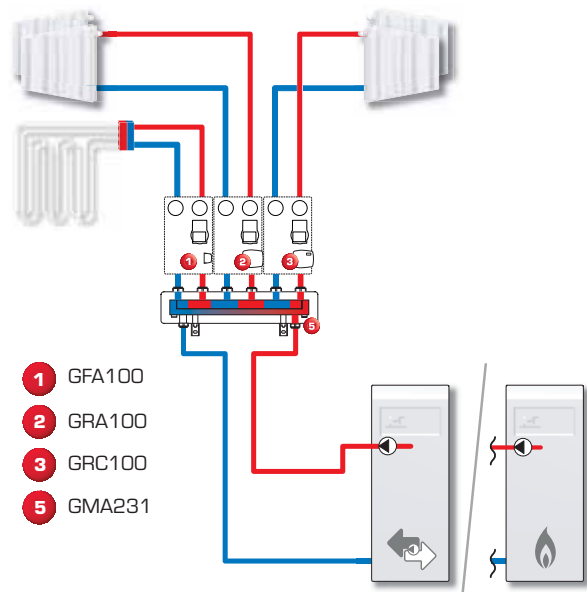

## CIRCULATION UNITS INSTALLATION EXAMPLES

1

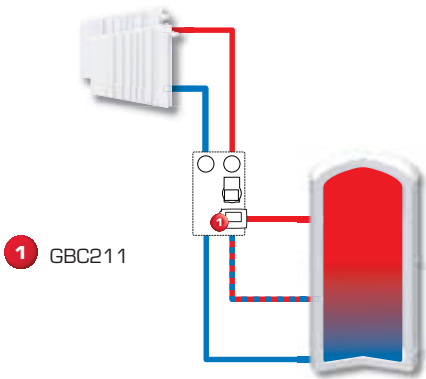

3

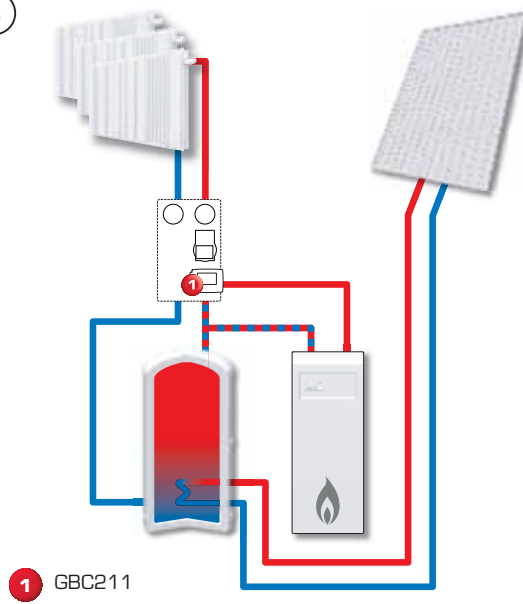

2

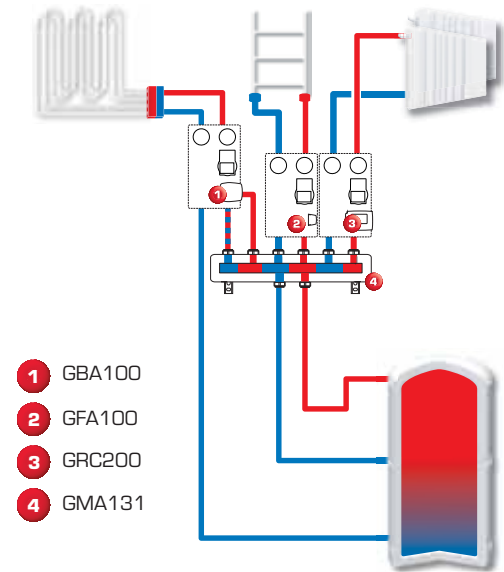

4

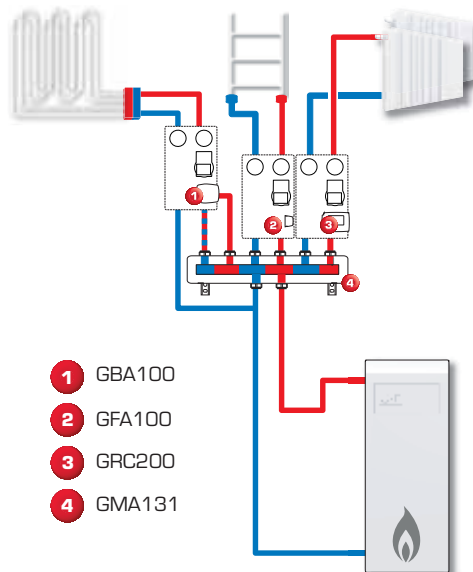



# CIRCULATION UNITS INSTALLATION EXAMPLES

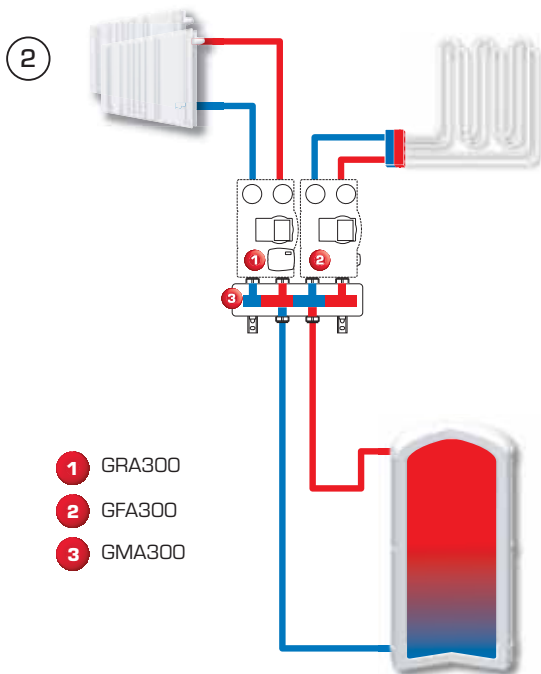
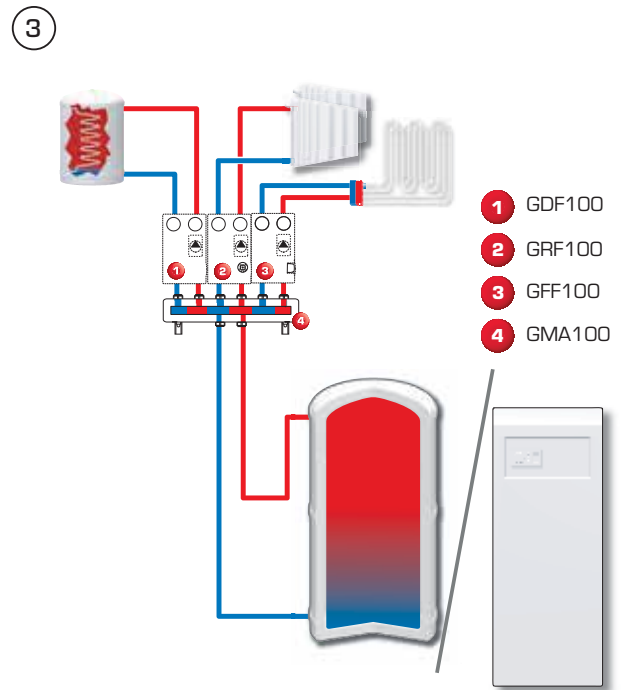
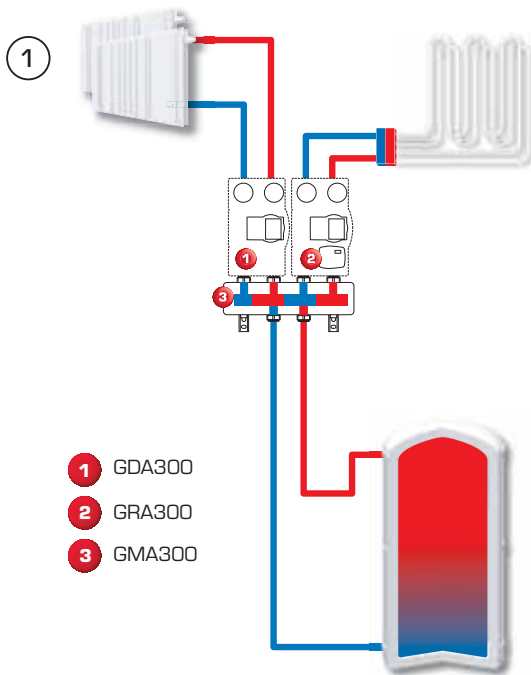

# RETURN TEMPERATURE UNITS TAKE CONTROL

Using the **ESBE Return Temperature Units** you will gain **perfect control** over the return temperature in your heating system. This is our brand new product segment which increase your boilers life time. It ensures high combustion temperature and nevertheless you get the lowest possible emissions.



With Controller ready and mounted on the Return temperature unit. Registered design.



GSC111



GSC112

## RETURN TEMPERATURE UNIT

### Motorized, mixing function series GSC110

- **Constant temperature high accuracy control**
- **Best regulation performance**
- **System pre balance**
- **High efficiency circulation pump**

The ESBE series GSC is a return temperature unit designed for applications, where the return temperature control is required. Equipped with two shut-off valves with thermometers, check valve, high class isolation shell and high efficiency circulation pump. The GSC series is delivered with constant temperature controller for high accuracy control and 3-way rotary mixing valve for the best regulation performance.

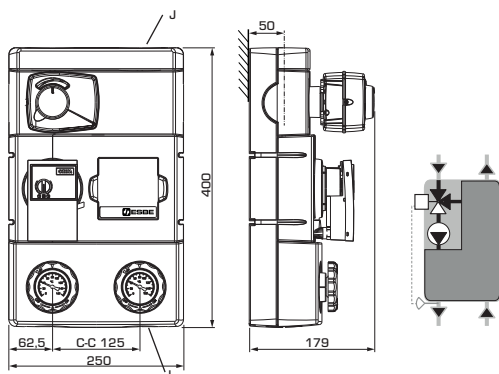

#### TECHNICAL DATA

Pressure class: \_\_\_\_\_ PN 6  
 Media temperature: \_\_\_\_\_ max. +110°C  
 \_\_\_\_\_ min. 0°C  
 Ambient temperature: \_\_\_\_\_ max. +50°C  
 \_\_\_\_\_ min. 0°C  
 Working pressure: \_\_\_\_\_ 0,6 MPa (6 bar)  
 Connections: \_\_\_\_\_ Internal thread (G), ISO 228/1  
 \_\_\_\_\_ External thread (G), ISO 228/1  
 Insulation: \_\_\_\_\_ EPP λ 0,036 W/mK  
 Media: \_\_\_\_\_ Heating water (in accordance with VDI2035)  
 \_\_\_\_\_ Water / Glycol mixtures, max. 50%  
 [above 20% admixture, the pumping data must be checked]

Material, in contact with water:  
 Components of: \_\_\_\_\_ Brass, Iron, Copper  
 Sealing material of: \_\_\_\_\_ PTFE, Aramid fibre, EPDM

Conformities and certificates:  
 PED 2014/68/EU, article 4.3

CE LVD 2014/35/EU  
 EMC 2014/30/EU  
 RoHS 2011/65/EU

EFP READY 2015 ErP 2009/125/EU  
 ErP 2015  
 ENEV 2014 EnEV 2014

#### With Controller CRA111, constant temperature control

Art. No.	Reference	DN	Pump	Temperature range	Connections		Weight [kg]	Note
					I	J		
61140200	GSC111	25	Wilo 25/6	5-95 °C	G 1"	G 1½"	6,0	
61140400		32	Wilo 25/7,5		G 1¼"		7,4	
61140600	GSC112	25	Grundfos 25-50	5-95 °C	G 1"	G 1½"	6,1	
61140800		32	Grundfos 25-70		G 1¼"		7,5	



#### ADDITIONAL GUIDANCE

Accessories..... 19  
 Guide & Dimensioning..... 33

Installation examples..... 35  
 For further detailed information ..... [www.esbe.eu](http://www.esbe.eu)

# RETURN TEMPERATURE UNITS

With Actuator ready and mounted on the Return temperature unit. Registered design.



GSA111

GSA112

## RETURN TEMPERATURE UNIT

### Motorized, mixing function series GSA

- **System pre balance**
- **Best regulation performance**
- **High class insulation shell**
- **Ready to use with most return temperature and boiler controllers**

The ESBE series GSA is a return temperature unit designed for applications, where the return temperature control is required. Equipped with two shut-off valves with thermometers, check valve, high class isolation shell and high efficiency circulation pump. The GSA series is delivered with the 3-way rotary mixing valve and actuator. The Return Temperature Unit GSA100 ensures pre balanced system and best regulation performances, as well the working possibility with most controllers available on the market.

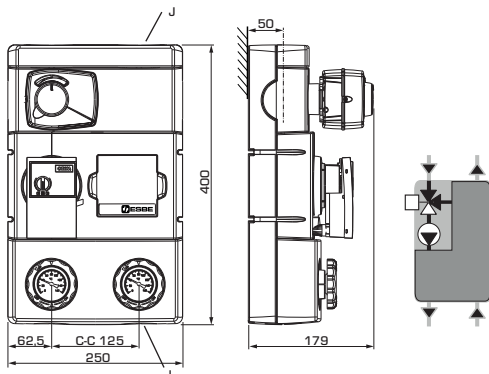

#### TECHNICAL DATA

Pressure class: \_\_\_\_\_ PN 6  
 Media temperature: \_\_\_\_\_ max. +110°C  
 \_\_\_\_\_ min. 0°C  
 Ambient temperature: \_\_\_\_\_ max. +50°C  
 \_\_\_\_\_ min. 0°C  
 Working pressure: \_\_\_\_\_ 0,6 MPa (6 bar)  
 Connections: \_\_\_\_\_ Internal thread (G), ISO 228/1  
 \_\_\_\_\_ External thread (G), ISO 228/1  
 Insulation: \_\_\_\_\_ EPP λ 0,036 W/mK  
 Media: \_\_\_\_\_ Heating water (in accordance with VDI2035)  
 \_\_\_\_\_ Water / Glycol mixtures, max. 50%  
 (above 20% admixture, the pumping data must be checked)

Material, in contact with water:  
 Components of: \_\_\_\_\_ Brass, Iron, Copper  
 Sealing material of: \_\_\_\_\_ PTFE, Aramid fibre, EPDM

Conformities and certificates:  
 PED 2014/68/EU, article 4.3

CE LVD 2014/35/EU  
 EMC 2014/30/EU  
 RoHS 2011/65/EU



ErP 2009/125/EU  
 ErP 2015  
 EnEV 2014

#### With Actuator ARA651, 230V 3-point

Art. No.	Reference	DN	Pump	Temperature range	Connections		Weight [kg]	Note
					I	J		
61140100	GSA111	25	Wilo 25/6	by external control unit	G 1"	G 1½"	5,6	
61140300		32	Wilo 25/7,5		G 1¼"		6,4	
61140500	GSA112	25	Grundfos 25-50	by external control unit	G 1"	G 1½"	5,7	
61140700		32	Grundfos 25-70		G 1¼"		6,5	



#### ADDITIONAL GUIDANCE

Accessories..... 19  
 Guide & Dimensioning..... 33

Installation examples..... 35  
 For further detailed information..... [www.esbe.eu](http://www.esbe.eu)



Return temperature unit with integrated thermostatic valve. Registered design.  
 Series GST14x: Adjustable temperature range.  
 Series GST13x: Fixed temperature settings.



GST141



GST142



GST131



GST132

## RETURN TEMPERATURE UNIT

### Thermostatic, mixing function series GST

- **Thermostatic constant temperature control**
- **Available with fixed or adjustable temperature setting**
- **High class isolation shell**
- **High efficiency circulation pump**

The ESBE series GST is a return temperature unit designed for applications, where the return temperature control is required. Equipped with two shut-off valves with thermometers, check valve, high class isolation shell and high efficiency circulation pump. The GST series is delivered with the 3-way thermostatic mixing valve, which comes with two versions: fixed temperature or adjustable temperature setting.

#### TECHNICAL DATA

Pressure class: \_\_\_\_\_ PN 6  
 Media temperature: \_\_\_\_\_ max. +110°C  
 \_\_\_\_\_ min. 0°C  
 Ambient temperature: \_\_\_\_\_ max. +50°C  
 \_\_\_\_\_ min. 0°C  
 Working pressure: \_\_\_\_\_ 0,6 MPa (6 bar)  
 Connections: \_\_\_\_\_ Internal thread (G), ISO 228/1  
 \_\_\_\_\_ External thread (G), ISO 228/1  
 Insulation: \_\_\_\_\_ EPP λ 0,036 W/mK  
 Media: \_\_\_\_\_ Heating water (in accordance with VDI2035)  
 \_\_\_\_\_ Water / Glycol mixtures, max. 50%  
 (above 20% admixture, the pumping data must be checked)

Material, in contact with water:  
 Components of: \_\_\_\_\_ Brass, Iron, Copper  
 Sealing material of: \_\_\_\_\_ PTFE, Aramid fibre, EPDM

Conformities and certificates:  
 PED 2014/68/EU, article 4.3

CE LVD 2014/35/EU  
 EMC 2014/30/EU  
 RoHS 2011/65/EU

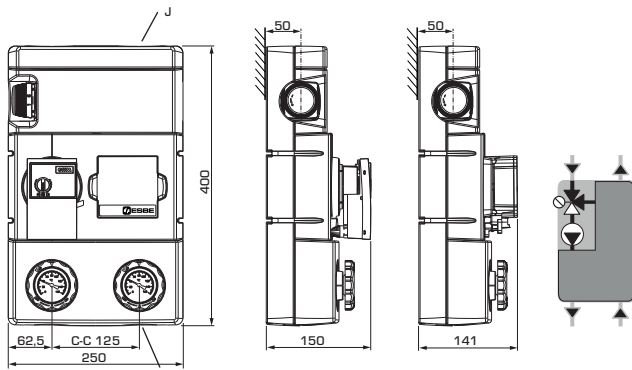
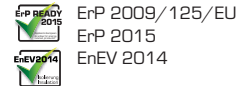

Art. No.	Reference	DN	Pump	Temperature range	Connections		Weight [kg]	Note
					I	J		
61120200	GST141	25	Wilo 25/6	50-75°C	G 1"	G 1½"	5,4	
61120300		32	Wilo 25/7,5		G 1¼"			
61120500	GST142	25	Grundfos 25-50	50-75°C	G 1"	G 1½"	5,5	
61120600		32	Grundfos 25-70		G 1¼"			
61120100	GST131	25	Wilo 25/6	50/55/60 °C	G 1"	G 1½"	5,3	1)
61120400	GST132		Grundfos 25-50					



#### ADDITIONAL GUIDANCE

Accessories..... 19  
 Guide & Dimensioning..... 33-34

Installation examples..... 35  
 For further detailed information ..... [www.esbe.eu](http://www.esbe.eu)

Notes: 1) The Return Temperature Units Series GST130 are delivered with three wax elements: 50/55/60°C. Factory assembly: 55°C.

With Controller ready and mounted on the Return temperature unit. Registered design.



GSC121



GSC122

## RETURN TEMPERATURE UNIT

Motorized, bivalent mixing function series GSC120

- **Constant temperature with high accuracy control**
- **Equipped with bivalent valve**
- **High efficiency circulation pump**
- **Perfect stratification and efficient load of the accumulation tank**

The ESBE series GSC is a return temperature unit designed for applications, where the return temperature control and correct stratification in accumulation tank is required. Equipped with two shut-off valves with thermometers, check valve, high class isolation shell and high efficiency circulation pump. The GSC series is delivered with constant temperature controller for high accuracy control and bivalent rotary mixing valve for the perfect stratification and efficient load of the accumulation tank.

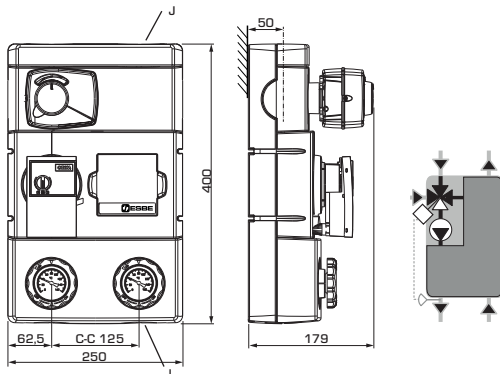

### TECHNICAL DATA

Pressure class: \_\_\_\_\_ PN 6  
 Media temperature: \_\_\_\_\_ max. +110°C  
 \_\_\_\_\_ min. 0°C  
 Ambient temperature: \_\_\_\_\_ max. +50°C  
 \_\_\_\_\_ min. 0°C  
 Working pressure: \_\_\_\_\_ 0,6 MPa (6 bar)  
 Connections: \_\_\_\_\_  
 \_\_\_\_\_ Internal thread (G), ISO 228/1  
 \_\_\_\_\_ External thread (G), ISO 228/1  
 Insulation: \_\_\_\_\_ EPP λ 0,036 W/mK  
 Media: \_\_\_\_\_ Heating water (in accordance with VDI2035)  
 \_\_\_\_\_ Water / Glycol mixtures, max. 50%  
 (above 20% admixture, the pumping data must be checked)  
 Material, in contact with water:  
 Components of: \_\_\_\_\_ Brass, Iron, Copper  
 Sealing material of: \_\_\_\_\_ PTFE, Aramid fibre, EPDM

Conformities and certificates:  
 PED 2014/68/EU, article 4.3

CE LVD 2014/35/EU  
 EMC 2014/30/EU  
 RoHS 2011/65/EU



ErP 2009/125/EU  
 ErP 2015  
 EnEV 2014

### With Controller CRA111, constant temperature control

Art. No.	Reference	DN	Pump	Temperature range	Connections		Weight [kg]	Note
					I	J		
61160100	GSC121	25	Wilo 25/6	5-95 °C	G 1"	G 1½"	6,0	
61160200		32	Wilo 25/7,5		G 1¼"		6,5	
61160300	GSC122	25	Grundfos 25-50	5-95 °C	G 1"	G 1½"	6,0	
61160400		32	Grundfos 25-70		G 1¼"		6,6	



### ADDITIONAL GUIDANCE

Accessories.....19  
 Guide & Dimensioning.....34

Installation examples.....35  
 For further detailed information..... [www.esbe.eu](http://www.esbe.eu)

# RETURN TEMPERATURE UNITS DIMENSIONING

Example: Start with the heat output of the boiler (e.g. 40 kW) and move horizontally to the right in the diagram to the chosen  $\Delta t$  (recommended by boiler supplier), which is the temperature difference between the riser from the boiler and the return to the boiler (e.g. 80°C - 65°C = 15°C).

Move vertically up to the curves representing load unit performance. Check that the pump curve overcomes the additional pressure drops in system components such as pipes, boiler and storage tank.

## SERIES GSC110, GSA110 – available pressure Wilo

Pump Capacity diagram

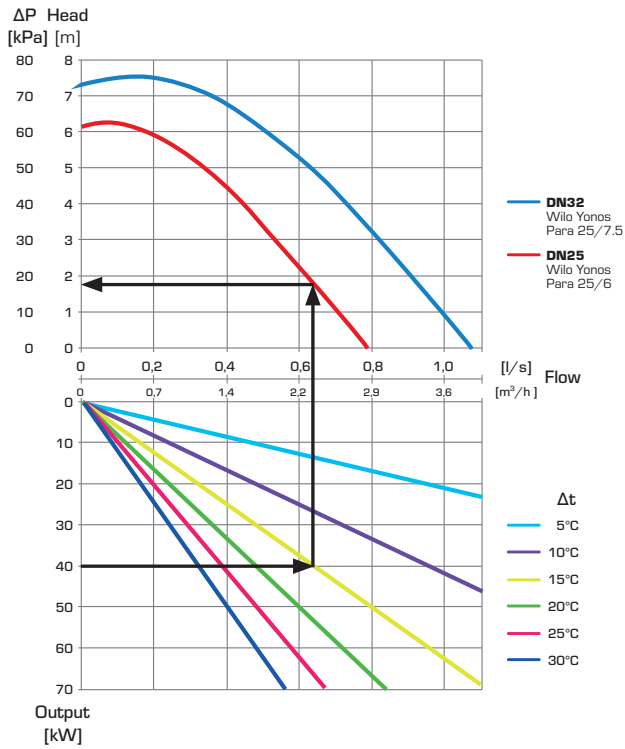

## SERIES GST130 – available pressure Wilo

Pump Capacity diagram

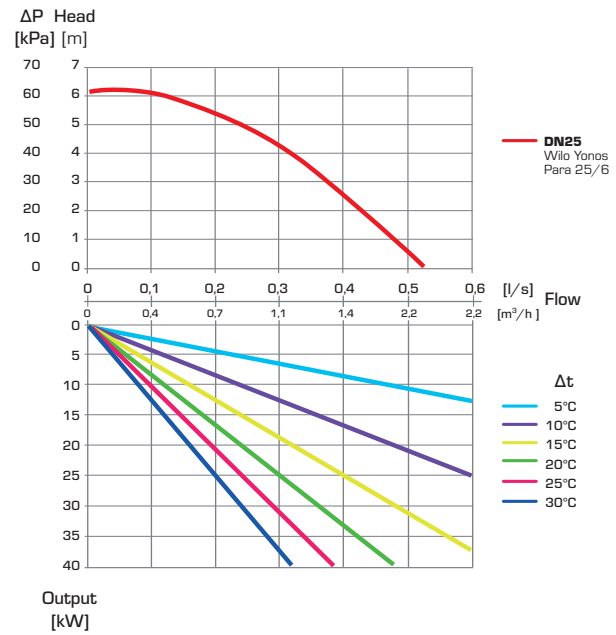

## SERIES GSC110, GSA110 – available pressure Grundfos

Pump Capacity diagram

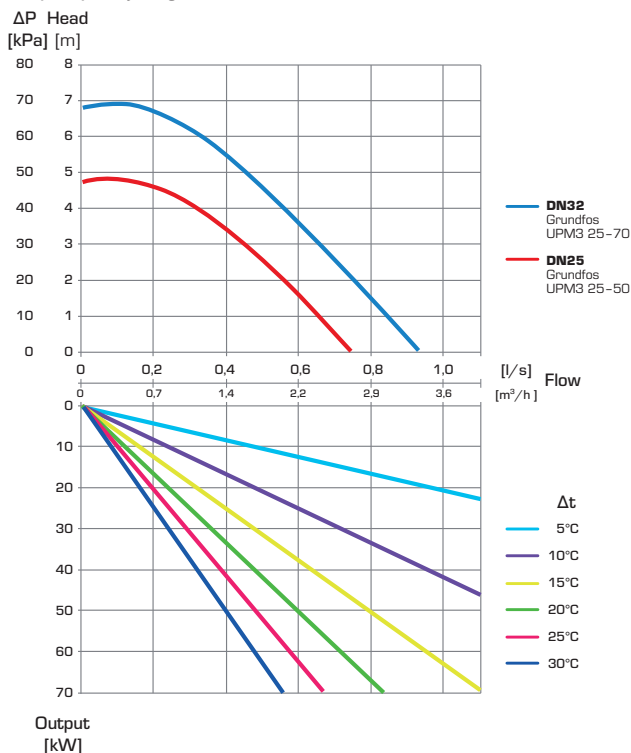

## SERIES GST130 – available pressure Grundfos

Pump Capacity diagram

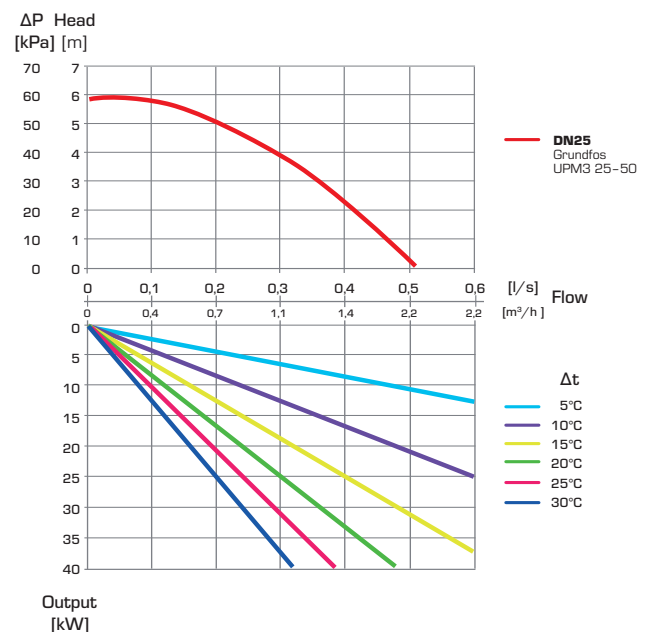

For further detailed information.....www.esbe.eu

# RETURN TEMPERATURE UNITS DIMENSIONING

## SERIES GST140 – available pressure Wilo

Pump Capacity diagram

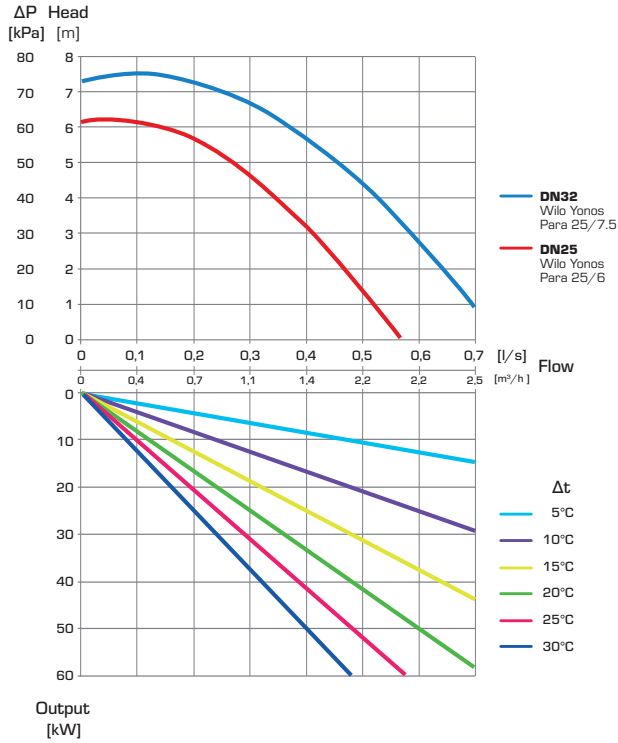

## SERIES GSC120 – available pressure Wilo

Pump Capacity diagram

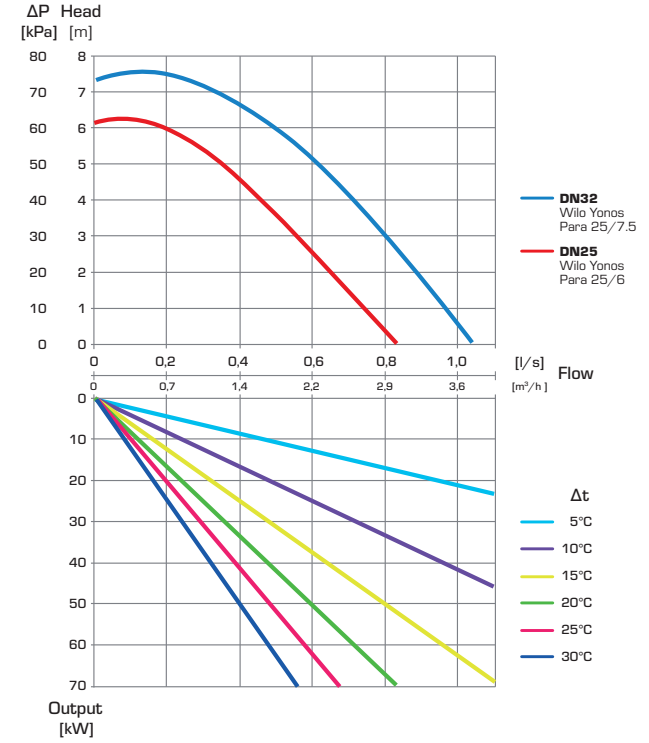

## SERIES GST140 – available pressure Grundfos

Pump Capacity diagram

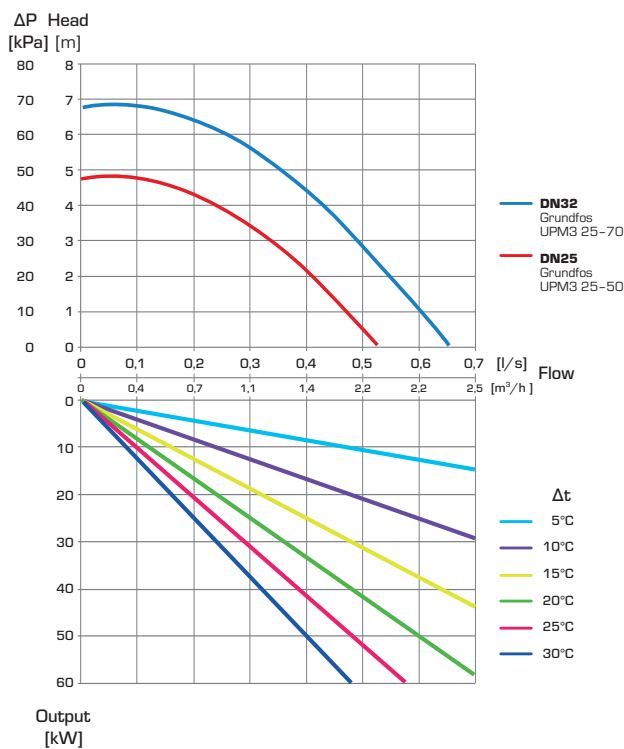

## SERIES GSC120 – available pressure Grundfos

Pump Capacity diagram

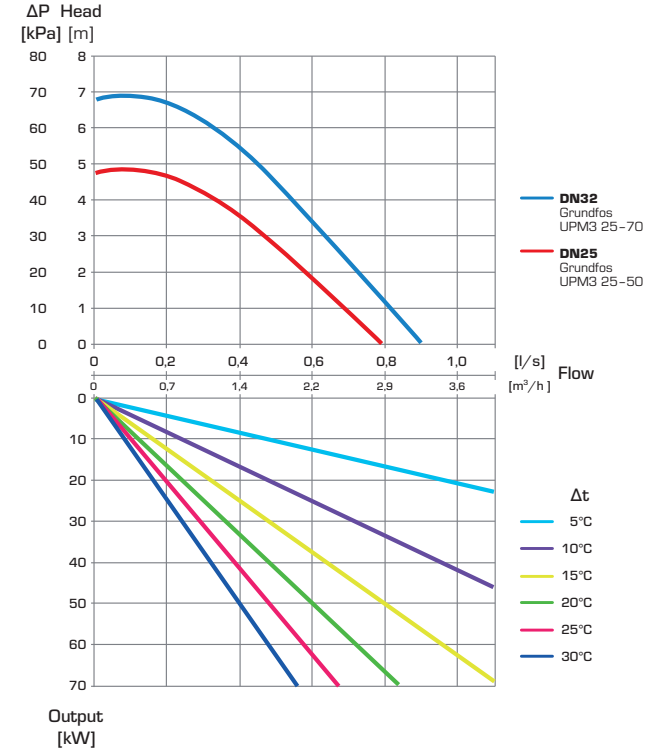



# RETURN TEMPERATURE UNITS INSTALLATION EXAMPLES

1

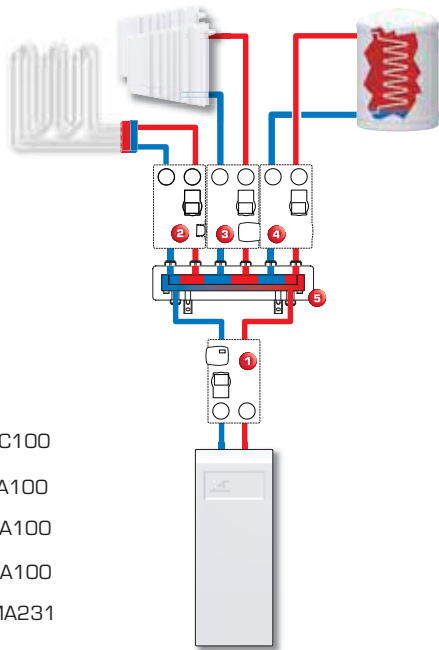

3

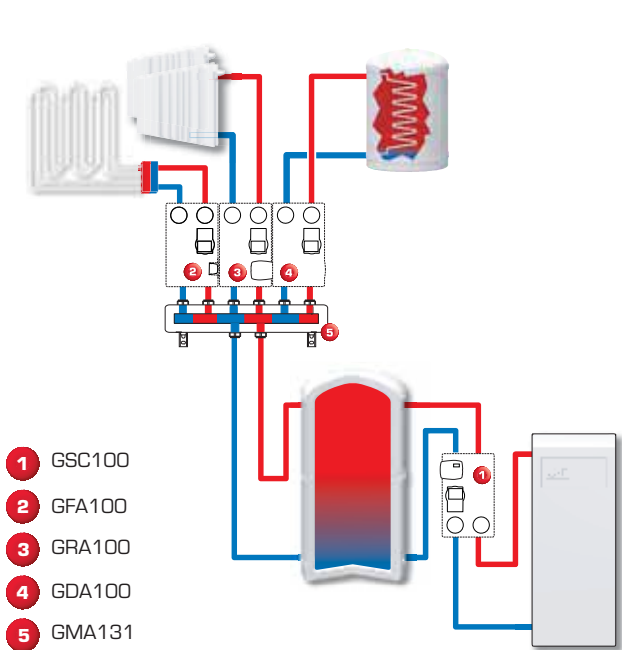

2

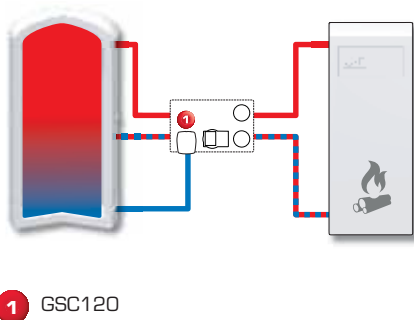

# FRESH HYDRO UNITS

## FAST AND EFFICIENT SUPPLY

**The Fresh Hydro Unit**, a high sophisticated device with outstanding performance, are designed for potable water heating applications. The temperature is constant and the waiting time is zero thanks to the fastest valve ESBE ever made built-in to the unit.





FSK101



FSK803

## FRESH HYDRO UNIT Series FSK100

- All time fresh, vital and hygienic drinking water in the demanded volume
- High tap rates
- Fast reaction times
- Lowest calcification risk
- Legionella flushing function

The Series FSK100 are designed for potable water applications. Equipped with unique hydro block, quick mixing actuator, two pass plate heat exchangers and intelligent controller the FSK100 series are one of a kind. These high sophisticated appliances provide outstanding potable water performance and temperature stability. The FSK100 series set a new standard on fresh hydro units market.

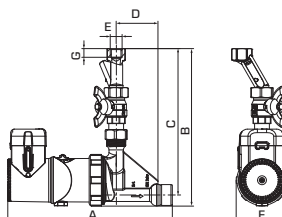
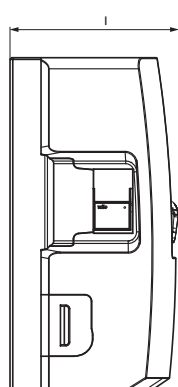
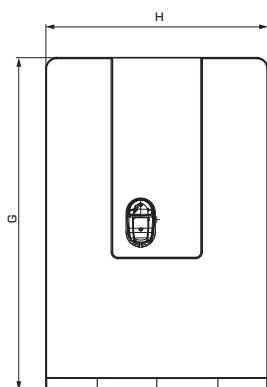

### TECHNICAL DATA

#### The Fresh hydro unit, in general:

Tap performance: 40 l/min \_\_\_\_\_ - at 70°C primary  
 \_\_\_\_\_ - at 45°C outlet secondary

Plate heat exchanger (plates): \_\_\_\_\_ 41

Insulation: \_\_\_\_\_ EPP

Weight: \_\_\_\_\_ 20 kg

Connections,

- cold water (A): \_\_\_\_\_ G 1" Internal thread, ISO 228/1

- warm water (B): \_\_\_\_\_ G 1" Internal thread, ISO 228/1

- storage tank (C): \_\_\_\_\_ G 1" External thread, ISO 228/1

- storage tank (D): \_\_\_\_\_ G 1" External thread, ISO 228/1

- circulation (E): \_\_\_\_\_ G 1/2" Internal thread, ISO 228/1

- flush connection (F): \_\_\_\_\_ G 1/2" Internal thread, ISO 228/1

Media temperature: \_\_\_\_\_ max. 95°C, min. 2°C

Media, primary side: \_\_\_\_\_ Heating water (in accordance with VD2035)

Working pressure, - potable water: \_\_\_\_\_ 1 MPa (10 bar)

- heating: \_\_\_\_\_ 300 kPa (3 bar)

#### Primary pump:

Type: \_\_\_\_\_ Yonos PARA HU 25/7,0 PWM 1W

Power supply: \_\_\_\_\_ 230 V, 50Hz

Speed: \_\_\_\_\_ 800 - 4650 rpm

Power consumption: \_\_\_\_\_ 3 - 45 W

Current, nominal: \_\_\_\_\_ 0,03 - 0,44 A

#### 3-way Mixing valve SLB239

Type: \_\_\_\_\_ ESBE SLB239

Power supply: \_\_\_\_\_ 12 ± 15% V DC

Power consumption, standby: \_\_\_\_\_ 0,6 W

Current, peak: \_\_\_\_\_ 0,8 A

#### optional Circulation pump:

Type: \_\_\_\_\_ Xylem E3-00-3/000 BRU

Power supply: \_\_\_\_\_ 230 V, 50Hz

Power consumption: \_\_\_\_\_ 8 W

Current, nominal: \_\_\_\_\_ < 0,1 A

Conformities and certificates:

PED 2014/68/EU, article 4.3

CE LVD 2014/35/EU  
 EMC 2014/30/EU  
 RoHS 2011/65/EU



ErP 2009/125/EU  
 ErP 2015  
 ErEV 2014

Art. No.	Reference	Pump	Connections (see Technical data)						Dimensions			Weight [kg]	Note
			A	B	C	D	E	F	G	H	I		
64000100	FSK101	Wilo 25/7,0	G 1"	G 1"	G 1"	G 1"	G 1/2"	G 1/2"	600	400	304	20,0	

### ACCESSORIES Circulation unit with pump and electronic return thermostat

Art. No.	Reference	Connection E	Dimensions						Weight [kg]	Note
			A	B	C	D	F	G		
64020100	FSK803	G 1/2"	229	219	203	58	72	12	1,75	



### ADDITIONAL GUIDANCE

Guide & Dimensioning ..... 38  
 Installation examples ..... 39

For further detailed information ..... [www.esbe.eu](http://www.esbe.eu)

# FRESH HYDRO UNITS

## DIMENSIONING OF THE BUFFERTANK, MAX. HWC AND FLOW RESISTANCE

T buffer	Setting tap temperature	Min. volume of buffer tank per liter HWC (factor)	Transfer performance	Transferred energy per liter HWC	Max. HWC	Return temperature at max. HWC	Return temperature primary side at low tap volume (5l/min.)	Pressure drop secondary side at max. Tap volume
50°C	40°C	1,0	63 kW	34,9 Wh	30,0 l/min	19,0°C	20,0°C	0,8 bar
	45°C	1,3	61 kW	40,7 Wh	25,0 l/min	23,0°C	23,0°C	0,6 bar
55°C	40°C	0,9	84 kW	34,9 Wh	40,0 l/min	18,0°C	18,0°C	1,5 bar
	45°C	1,1	73 kW	40,7 Wh	30,0 l/min	22,0°C	21,0°C	0,8 bar
	50°C	1,5	56 kW	46,5 Wh	20,0 l/min	27,0°C	27,0°C	0,4 bar
60°C	40°C	0,7	84 kW	34,9 Wh	40,0 l/min	17,0°C	17,0°C	1,5 bar
	45°C	0,9	85 kW	40,7 Wh	35,0 l/min	20,0°C	18,0°C	1,1 bar
	50°C	1,1	70 kW	46,5 Wh	25,0 l/min	23,0°C	21,0°C	0,6 bar
	55°C	1,5	63 kW	52,3 Wh	20,0 l/min	29,0°C	28,0°C	0,4 bar
65°C	40°C	0,7	84 kW	34,9 Wh	40,0 l/min	16,0°C	16,0°C	1,5 bar
	45°C	0,8	98 kW	40,7 Wh	40,0 l/min	19,0°C	18,0°C	1,5 bar
	50°C	1,0	84 kW	46,5 Wh	30,0 l/min	21,0°C	20,0°C	0,8 bar
	55°C	1,2	79 kW	52,3 Wh	25,0 l/min	27,0°C	24,0°C	0,6 bar
	60°C	1,6	70 kW	58,2 Wh	20,0 l/min	32,0°C	32,0°C	0,4 bar
70°C	40°C	0,6	84 kW	34,9 Wh	40,0 l/min	16,0°C	15,0°C	1,5 bar
	45°C	0,7	98 kW	40,7 Wh	40,0 l/min	18,0°C	17,0°C	1,5 bar
	50°C	0,8	98 kW	46,5 Wh	35,0 l/min	20,0°C	20,0°C	1,1 bar
	55°C	1,0	94 kW	52,3 Wh	30,0 l/min	23,0°C	22,0°C	0,8 bar
	60°C	1,2	87 kW	58,2 Wh	25,0 l/min	27,0°C	26,0°C	0,6 bar

**EXAMPLE :**

**Assumptions:**

Required tap volume	150 l
T Buffer	60°C
Setting tap temperatures	50°C

**Table Values:**

Min. volume of buffer tank per liter PWH (factor)	1,1
Max. PWH	25 l/min
Return temperature at max. PWH	23°C
Return temperature primary side at low tap volume (5l/min.)	21°C
Pressure drop secondary side at max. Tap volume	0,6 bar

**Calculation of the minimum buffer dimension:**

150 l x 1,1 =	165 l
---------------	-------

**Specified values are indicative and valid under the following conditions:**

- The calculated buffer volume is completely heated up
- A clear layering inside the buffertank and a clear back layering
- Temperature of the cold water = 10°C
- Efficiency losses are not taken into account
- Flow resistors are not taken into account.



# FRESH HYDRO UNITS DIMENSIONING

## FSK803 - Pump Capacity diagram

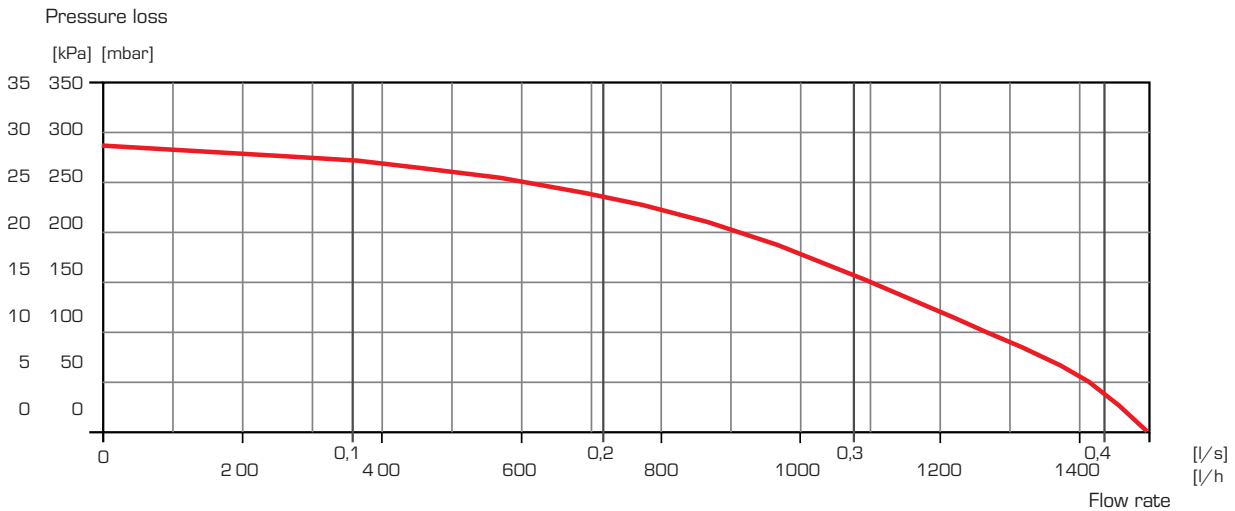

## INSTALLATION EXAMPLES

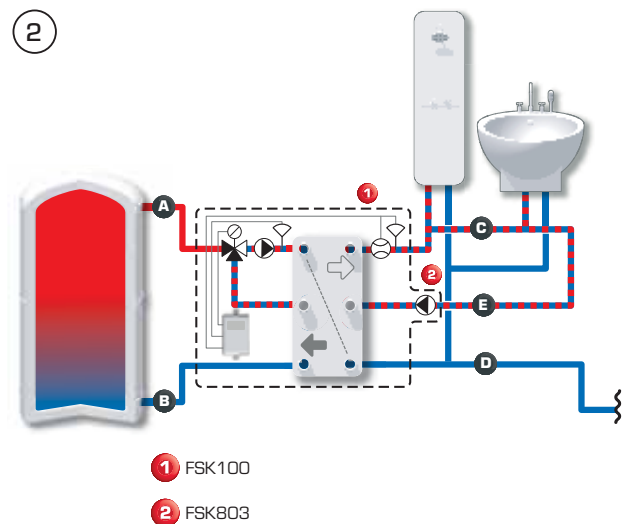
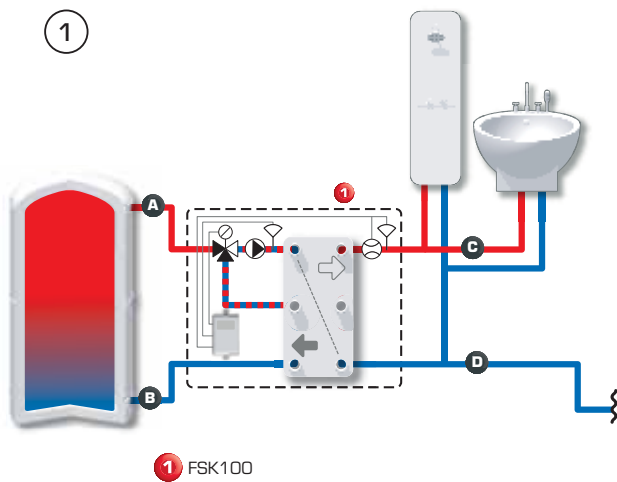

## STRUCTURE

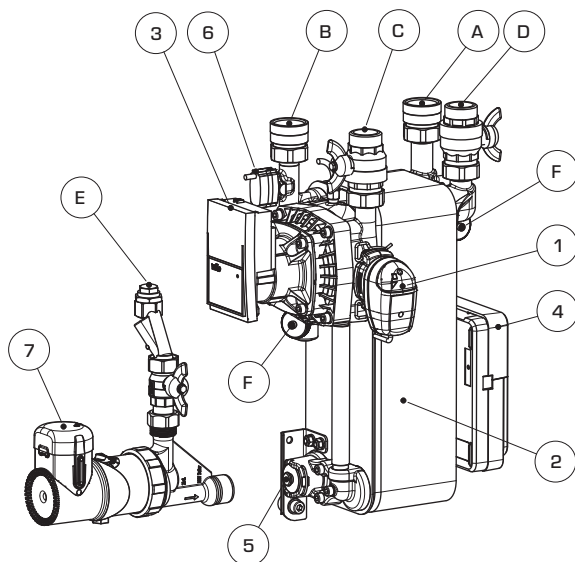

A	B	C	D	E	F
G 1"	G 1"	G 1"	G 1"	G 1/2"	G 1/2"

- 1 Control valve SLB239
  - 2 Plate heat exchanger
  - 3 Primary pump, Wilo Yonos PARA HU 25/7,0 PWM 1W
  - 4 Controller (Fresh Hydro Control)
  - 5 Push-in connection for circulation unit
  - 6 Flow sensor
  - 7 Optional Circulation unit with pump and electronic return thermostat (for pulse or time mode)
- A Cold water connection  
B Warm water connection  
C Storage tank connection  
D Storage tank connection  
E Circulation connection  
F Flush connection

# ROTARY VALVES

## QUICK AND EASY INSTALLATION

**ESBE offers a wide range of rotary valves** in a number of different designs for the regulation of heating and cooling. Add to that many different actuators for simple and quick installation to the valve.





Patented +  
Registered design

## MIXING VALVE

### Series VRG130

- **Superb regulation for highest performance**
- **Lowest internal leakage on the market (< 0,05%)**
- **Compact, flexible and easy to install**
- **Long lasting and high durability**
- **Perfect match between the valve and ESBE actuators**

Series VRG130 are 3-way valves suitable for mixing or diverting operation. The valves are made of high-performing brass allowing use in heating and cooling installations. The VRG series is available in DN15-50 and comes with different types of connections to suit most pipe dimensions. The valve is perfectly combined with ESBE actuators and controllers.

#### TECHNICAL DATA

Pressure class: \_\_\_\_\_ PN 10  
 Media temperature: \_\_\_\_\_ max. (continuously) +110°C  
 \_\_\_\_\_ max. (temporarily) +130°C  
 \_\_\_\_\_ min. -10°C  
 Torque (at nominal pressure) DN15-32: \_\_\_\_\_ < 3 Nm  
 DN40-50: \_\_\_\_\_ < 5 Nm  
 Leakrate in % of flow\*: \_\_\_\_\_ Mixing < 0,05%  
 \_\_\_\_\_ Diverting < 0,02%  
 Working pressure: \_\_\_\_\_ 1 MPa (10 bar)  
 Max. differential pressure drop: \_\_\_\_\_ Mixing, 100 kPa (1 bar)  
 \_\_\_\_\_ Diverting, 200 kPa (2 bar)  
 Close off pressure: \_\_\_\_\_ 200 kPa (2 bar)  
 Rangeability Kv/Kv<sup>min</sup>, A-AB: \_\_\_\_\_ 100  
 Connections: \_\_\_\_\_ Internal thread (Rp), EN 10226-1  
 \_\_\_\_\_ External thread (G), ISO 228/1  
 \_\_\_\_\_ Compression fitting (CPF), EN 1254-2  
 Media: \_\_\_\_\_ Heating water (in accordance with VD12035)  
 \_\_\_\_\_ Water / Glycol mixtures, max. 50%\*\*  
 \_\_\_\_\_ Water / Ethanol mixtures, max. 28%

Material  
 Valve body: \_\_\_\_\_ Dezincification resistant brass, DZR  
 Slide: \_\_\_\_\_ Abrasion resistant brass  
 Shaft and bushing: \_\_\_\_\_ PPS composite  
 O-rings: \_\_\_\_\_ EPDM

PED 2014/68/EU, article 4.3

\* Differential pressure 100 kPa (1 bar)  
 \*\* Additional guidance - page 54

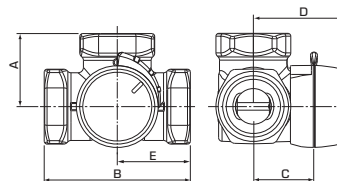

**VRG131** Internal thread

Art. No.	Reference	DN	Kvs	Connection	A	B	C	D	E	Weight [kg]	Note
11600100	VRG131	15	0,4	Rp 1/2"	36	72	32	50	36	0,40	
11600200			0,63								
11600300			1								
11600400			1,6								
11600500			2,5								
11600600			4								
11600700		20	2,5	Rp 3/4"	36	72	32	50	36	0,43	
11600800			4								
11600900			6,3								
11601000		25	6,3	Rp 1"	41	82	34	52	41	0,70	
11601100			10								
11601200		32	16	Rp 1 1/4"	47	94	37	55	47	0,95	
11603400		40	25	Rp 1 1/2"	53	106	44	62	53	1,68	
11603600		50	40	Rp 2"	60	120	46	64	60	2,30	

**SEE NEXT PAGE FOR MORE TABLES »**



#### ADDITIONAL GUIDANCE

Accessories.....53, 88–89  
 Guide & Dimensioning.....54–55, 57, 59

Installation examples.....61  
 For further detailed information ..... [www.esbe.eu](http://www.esbe.eu)

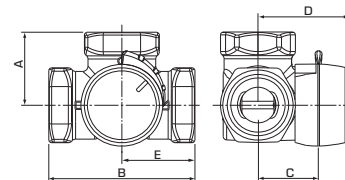

**VRG132** External thread

Art. No.	Reference	DN	Kvs	Connection	A	B	C	D	E	Weight [kg]	Note
11601500	VRG132	15	0,4	G 3/4"	36	72	32	50	36	0,40	
11601600			0,63								
11601700			1								
11601800			1,6								
11601900			2,5								
11602000		4									
11602100		20	2,5	G 1"	36	72	32	50	36	0,43	
11602200			4								
11602300			6,3								
11602400		25	6,3	G 1 1/4"	41	82	34	52	41	0,70	
11602500			10								
11602600			32								16
11603500		40	25	G 2"	53	106	44	62	53	1,69	
11603700		50	40	G 2 1/4"	60	120	46	64	60	2,30	

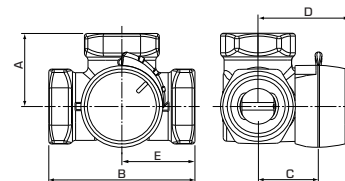

**VRG133** Compression fitting

Art. No.	Reference	DN	Kvs	Connection	A	B	C	D	E	Weight [kg]	Note
11602900	VRG133	20	4	CPF 22 mm	36	72	32	50		0,40	
11603000			6,3								
11603100		25	10	CPF 28 mm	41	82	34	52		0,45	

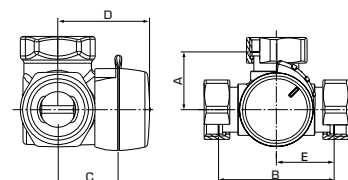

**VRG138** Rotating nut / External thread

Art. No.	Reference	DN	Kvs	Connection	A	B	C	D	E	Weight [kg]	Note
11603800	VRG138	20	4	2x RN 1" + G 1"	36	72	32	50	36	0,56	
11603900			4	3x RN 1"						0,59	
11604000			6,3	2x RN 1" + G 1"						0,56	
11604100			6,3	3x RN 1"						0,59	

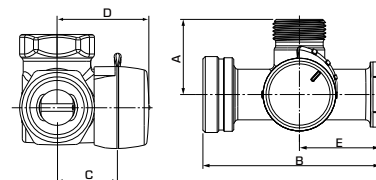

**VRG139** Pump flange / External thread

Art. No.	Reference	DN	Kvs	Connection	A	B	C	D	E	Weight [kg]	Note
11604400	VRG139	20	2,5	PF 1 1/2" + G 1 1/2" + G 1"	47,5	112	32	50	51	0,82	
11604500			6,3							0,82	
11604600			8							0,82	



**ADDITIONAL GUIDANCE**

Accessories.....53, 88–89  
Guide & Dimensioning.....54–55, 57, 59

Installation examples.....61  
For further detailed information ..... [www.esbe.eu](http://www.esbe.eu)

Registered design

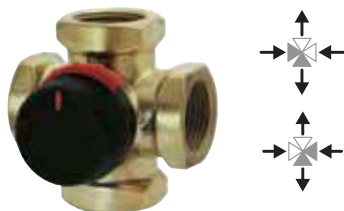

## MIXING VALVE

### Series VRG140

- **Superb regulation for best double mixing performance**
- **Compact, flexible and easy to install**
- **Long lasting and high durability**
- **Perfect match between the valve and ESBE actuators**

Series VRG140 are 4-way valves suitable for double mixing operation. The valves are made of high-performing brass allowing use in heating and cooling installations. The VRG series is available in DN15-50 and comes with different types of connections to suit most pipe dimensions. The valve is perfectly combined with ESBE actuators and controllers.

#### TECHNICAL DATA

Pressure class: \_\_\_\_\_ PN 10  
 Media temperature: \_\_\_\_\_ max. (continuously) +110°C  
 \_\_\_\_\_ max. (temporarily) +130°C  
 \_\_\_\_\_ min. -10°C  
 Torque (at nominal pressure) DN15-32: \_\_\_\_\_ < 3 Nm  
 DN40-50: \_\_\_\_\_ < 5 Nm  
 Leakrate in % of flow\*: \_\_\_\_\_ < 1,0%  
 Working pressure: \_\_\_\_\_ 1 MPa (10 bar)  
 Max. differential pressure drop: \_\_\_\_\_ 100 kPa (1 bar)  
 Close off pressure: \_\_\_\_\_ 100 kPa (1 bar)  
 Rangeability Kv/Kv<sup>min</sup>, A-AB: \_\_\_\_\_ 100  
 Connections: \_\_\_\_\_ Internal thread (Rp), EN 10226-1  
 \_\_\_\_\_ External thread (G), ISO 228/1  
 Media: \_\_\_\_\_ Heating water (in accordance with VDI2035)  
 \_\_\_\_\_ Water / Glycol mixtures, max. 50%\*\*  
 \_\_\_\_\_ Water / Ethanol mixtures, max. 28%

Material  
 Valve body: \_\_\_\_\_ Dezincification resistant brass DZR  
 Slide: \_\_\_\_\_ Abrasion resistant brass  
 Shaft and bushing: \_\_\_\_\_ PPS composite  
 O-rings: \_\_\_\_\_ EPDM

PED 2014/68/EU, article 4.3

\* Differential pressure 100 kPa (1 bar)  
 \*\* Additional guidance - page 54

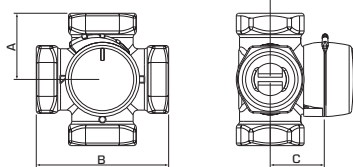

**VRG141** Internal thread

Art. No.	Reference	DN	Kvs	Connection	A	B	C	D	Weight [kg]	Note
11640100	VRG141	15	2,5	Rp 1/2"	36	72	32	50	0,40	
11640200		20	4	Rp 3/4"	36	72	32	50	0,52	
11640300			6,3							
11640400		25	10	Rp 1"	41	82	34	52	0,80	
11640500		32	16	Rp 1 1/4"	47	94	37	55	1,08	
11641500		40	25	Rp 1 1/2"	53	106	44	62	1,89	
11641700		50	40	Rp 2"	60	120	46	64	2,55	

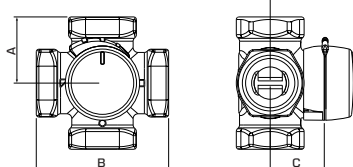

**VRG142** External thread

Art. No.	Reference	DN	Kvs	Connection	A	B	C	D	Weight [kg]	Note
11640900	VRG142	20	4	G 1"	36	72	32	50	0,52	
11641000			6,3							
11641100		25	10	G 1 1/4"	41	82	34	52	0,80	
11641200		32	16	G 1 1/2"	47	94	37	55	1,08	
11641600		40	25	G 2"	53	106	44	62	1,90	
11641800		50	40	G 2 1/4"	60	120	46	64	2,55	

FOR MORE VERSIONS ..... [WWW.ESBE.EU](http://WWW.ESBE.EU)



#### ADDITIONAL GUIDANCE

Accessories.....53, 88–89  
 Guide & Dimensioning.....54–55, 57, 59

Installation examples.....61  
 For further detailed information ..... [www.esbe.eu](http://www.esbe.eu)





Patented +  
Registered design

## MIXING VALVE

### Series VRG330

- **Superb regulation for best high flow mixing or diverting performance**
- **Lowest internal leakage on the market (<0,05%)**
- **Compact, flexible and easy to install**
- **Long lasting and high durability**
- **Perfect match between the valve and ESBE actuators**

Series VRG330 are valves suitable for high flow mixing or diverting operation. Basically is the valve function of series VRG330 the same as for VRG130 except the high-flow possibility. The valves are made of high-performing brass allowing use in heating and cooling installations. The VRG series is available in DN15-50 and comes with different types of connections to suit most pipe dimensions. The valve is perfectly combined with ESBE actuators and controllers.

#### TECHNICAL DATA

Pressure class: \_\_\_\_\_ PN 10  
 Media temperature: \_\_\_\_\_ max. (continuously) +110°C  
 \_\_\_\_\_ max. (temporarily) +130°C  
 \_\_\_\_\_ min. -10°C  
 Torque (at nominal pressure) DN15-32: \_\_\_\_\_ < 3 Nm  
 DN40-50: \_\_\_\_\_ < 5 Nm  
 Leakrate in % of flow\*: \_\_\_\_\_ < 0,05  
 Working pressure: \_\_\_\_\_ 1 MPa (10 bar)  
 Max. differential pressure drop: \_\_\_\_\_ Mixing, 100 kPa (1 bar)  
 \_\_\_\_\_ Diverting, 200 kPa (2 bar)  
 Close off pressure: \_\_\_\_\_ 200 kPa (2 bar)  
 Rangeability Kv/Kv<sup>min</sup>, A-AB: \_\_\_\_\_ 100  
 Connections: \_\_\_\_\_ Internal thread (Rp), EN 10226-1  
 \_\_\_\_\_ External thread (G), ISO 228/1  
 Media: \_\_\_\_\_ Heating water (in accordance with VDI2035)  
 \_\_\_\_\_ Water / Glycol mixtures, max. 50%\*  
 \_\_\_\_\_ Water / Ethanol mixtures, max. 28%  
 Material  
 Valve body: \_\_\_\_\_ Dezincification resistant brass, DZR  
 Slide: \_\_\_\_\_ Abrasion resistant brass  
 Shaft and bushing: \_\_\_\_\_ PPS composite  
 O-rings: \_\_\_\_\_ EPDM

PED 2014/68/EU, article 4.3

\* Differential pressure 100 kPa (1 bar)  
 \*\* Additional guidance - page 54



VRG331

VRG332

VRG338

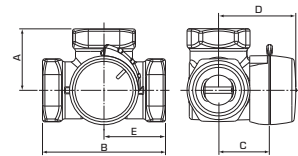

#### VRG331 Internal thread

Art. No.	Reference	DN	Kvs ■ - ▲	Kvs ■ - ●	Connection	A	B	C	D	E	Weight [kg]	Note
11700100	VRG331	20	13	8	Rp 3/4"	36	72	32	50	36	0,43	
11700200		25	17	10	Rp 1"	41	82	34	52	41	0,70	
11700300		32	32	20	Rp 1 1/4"	47	94	37	55	47	0,95	
11701100		40	45	30	Rp 1 1/2"	53	106	44	62	53	1,65	
11701300		50	65	40	Rp 2"	60	120	46	64	60	2,28	

#### VRG332 External thread

Art. No.	Reference	DN	Kvs ■ - ▲	Kvs ■ - ●	Connection	A	B	C	D	E	Weight [kg]	Note
11700600	VRG332	20	13	8	G 1"	36	72	32	50	36	0,43	
11700700		25	17	10	G 1 1/4"	41	82	34	52	41	0,70	
11700800		32	32	20	G 1 1/2"	47	94	37	55	47	0,95	
11701200		40	45	30	G 2"	53	106	44	62	53	1,66	
11701400		50	65	40	G 2 1/4"	60	120	46	64	60	2,28	

#### VRG338 Rotating nut

Art. No.	Reference	DN	Kvs ■ - ▲	Kvs ■ - ●	Connection	A	B	C	D	E	Weight [kg]	Note
11701500	VRG338	20	13	8	3 x RN 1"	36	72	32	50	36	0,57	



#### ADDITIONAL GUIDANCE

Accessories.....53, 88–89  
 Guide & Dimensioning.....54–55, 57, 59

Installation examples.....61  
 For further detailed information ..... [www.esbe.eu](http://www.esbe.eu)

Registered design

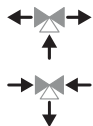

## CHANGE-OVER/DIVERTING VALVE Series VRG230

- **Superb regulation for best change over/diverting performance**
- **Compact, flexible and easy to install**
- **Long lasting and high durability**
- **Perfect match between the valve and ESBE actuators**

Series VRG230 are 3-way valves suitable for midport change-over/diverting operation. The valves are made of the high-performing brass allowing use in heating and cooling installations. The VRG series is available in DN15-50 and comes with different types of connections to suit most pipe dimensions. The valve is perfectly combined with ESBE actuators and controllers.

### TECHNICAL DATA

Pressure class: \_\_\_\_\_ PN 10  
 Media temperature: \_\_\_\_\_ max. (continuously) +110°C  
 \_\_\_\_\_ max. (temporarily) +130°C  
 \_\_\_\_\_ min. -10°C  
 Torque (at nominal pressure) DN15-32: \_\_\_\_\_ < 3 Nm  
 DN40-50: \_\_\_\_\_ < 5 Nm  
 Leakrate in % of flow\*: \_\_\_\_\_ < 0,5%  
 Working pressure: \_\_\_\_\_ 1 MPa (10 bar)  
 Max. differential pressure drop: \_\_\_\_\_ Diverting, 200 kPa (2 bar)  
 \_\_\_\_\_ Mixing, 100 kPa (1 bar)  
 Close off pressure: \_\_\_\_\_ 200 kPa (2 bar)  
 Rangeability Kv/Kv<sup>min</sup>, A-AB: \_\_\_\_\_ 100  
 Connections: \_\_\_\_\_ Internal thread (Rp), EN 10226-1  
 \_\_\_\_\_ External thread (G), ISO 228/1  
 \_\_\_\_\_ Compression fitting (CPF), EN 1254-2  
 Media: \_\_\_\_\_ Heating water (in accordance with VDI2035)  
 \_\_\_\_\_ Water / Glycol mixtures, max. 50%\*\*  
 \_\_\_\_\_ Water / Ethanol mixtures, max. 28%  
 Material  
 Valve body: \_\_\_\_\_ Dezincification resistant brass DZR  
 Slide: \_\_\_\_\_ Abrasion resistant brass  
 Shaft and bushing: \_\_\_\_\_ PPS composite  
 O-rings: \_\_\_\_\_ EPDM

PED 2014/68/EU, article 4.3

\* Differential pressure 100 kPa (1 bar)  
 \*\* Additional guidance - page 54



VRG231



VRG232



VRG233

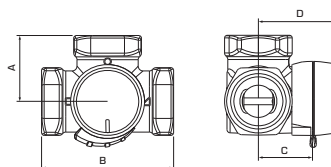

### VRG231 Internal thread

Art. No.	Reference	DN	Kvs	Connection	A	B	C	D	Weight [kg]	Note
11620100	VRG231	20	6,3	Rp 3/4"	36	72	32	50	0,43	
11620200		25	10	Rp 1"	41	82	34	52	0,70	
11620300		32	16	Rp 1 1/4"	47	94	37	55	0,95	
11621400		40	30	Rp 1 1/2"	53	106	44	62	1,72	
11621600		50	40	Rp 2"	60	120	46	64	2,39	

### VRG232 External thread

Art. No.	Reference	DN	Kvs	Connection	A	B	C	D	Weight [kg]	Note
11620600	VRG232	20	6,3	G 1"	36	72	32	50	0,43	
11620700		25	10	G 1 1/4"	41	82	34	52	0,70	
11620800		32	16	G 1 1/2"	47	94	37	55	0,95	
11621500		40	30	G 2"	53	106	44	62	1,73	
11621700		50	40	G 2 1/4"	60	120	46	64	2,39	

### VRG233 Compression fitting

Art. No.	Reference	DN	Kvs	Connection	A	B	C	D	Weight [kg]	Note
11621100	VRG233	20	4	CPF 22 mm	36	72	32	50	0,40	
11621200			6,3							
11621300		25	10	CPF 28 mm						

FOR MORE VERSIONS ..... [WWW.ESBE.EU](http://WWW.ESBE.EU)



### ADDITIONAL GUIDANCE

Accessories.....53, 88–89  
 Guide & Dimensioning.....54–55, 57, 59

Installation examples.....61–62  
 For further detailed information ..... [www.esbe.eu](http://www.esbe.eu)



Registered design

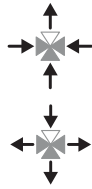

## BIVALENT MIXING VALVE Series VRB140

- **Superb regulation for best bivalent performance**
- **Compact, flexible and easy to install**
- **Long lasting and high durability**
- **Perfect match between the valve and ESBE actuators**

Series VRB140 are 4-way valves suitable for bivalent operations. The valve is made of high performing brass, allowing use in heating and cooling installations. The VRB series is available in DN15-50 and comes with different types of connections to suit most pipe dimensions. The valve is perfectly combined with ESBE actuators and controllers.

### TECHNICAL DATA

Pressure class: \_\_\_\_\_ PN 10  
 Media temperature: \_\_\_\_\_ max. (continuously) +110°C  
 \_\_\_\_\_ max. (temporarily) +130°C  
 \_\_\_\_\_ min. -10°C  
 Torque (at nominal pressure), DN15-32: \_\_\_\_\_ < 3 Nm  
 DN40-50: \_\_\_\_\_ < 5 Nm  
 Leakrate in % of flow\*: \_\_\_\_\_ < 0,5%  
 Working pressure: \_\_\_\_\_ 1 MPa (10 bar)  
 Max. differential pressure drop: \_\_\_\_\_ Mixing, 100 kPa (1 bar)  
 \_\_\_\_\_ Diverting, 200 kPa (2 bar)  
 Close off pressure: \_\_\_\_\_ 200 kPa (2 bar)  
 Rangeability Kv/Kv<sup>min</sup>, A-AB: \_\_\_\_\_ 100  
 Connections: \_\_\_\_\_ Internal thread (Rp), EN 10226-1  
 \_\_\_\_\_ External thread (G), ISO 228/1  
 \_\_\_\_\_ Compression fitting (CPF), EN 1254-2  
 Media: \_\_\_\_\_ Heating water (in accordance with VDI2035)  
 \_\_\_\_\_ Water / Glycol mixtures, max. 50%\*\*  
 \_\_\_\_\_ Water / Ethanol mixtures, max. 28%  
 Material  
 Valve body: \_\_\_\_\_ Dezincification resistant brass, DZR  
 Slide: \_\_\_\_\_ Abrasion resistant brass  
 Shaft and bushing: \_\_\_\_\_ PPS composite  
 O-rings: \_\_\_\_\_ EPDM

PED 2014/68/EU, article 4.3

\* Differential pressure 100 kPa (1 bar)  
 \*\* Additional guidance - page 54



VRB141



VRB142



VRB143

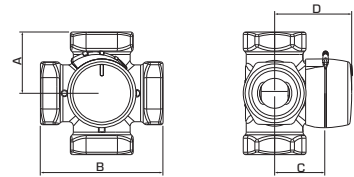

### VRB141 Internal thread

Art. No.	Reference	DN	Kvs	Connection	A	B	C	D	Weight [kg]	Note
11660100	VRB141	15	2,5	Rp 1/2"	36	72	32	50	0,40	
11660200			4	Rp 3/4"						
11660300		6,3								
11660400		25	10	Rp 1"	41	82	34	52	0,80	
11660500		32	16	Rp 1 1/4"	47	94	37	55	1,08	
11662000		40	25	Rp 1 1/2"	53	106	44	62	1,98	
11662200		50	35	Rp 2"	60	120	46	64	2,65	

### VRB142 External thread

Art. No.	Reference	DN	Kvs	Connection	A	B	C	D	Weight [kg]	Note
11660800	VRB142	15	2,5	G 3/4"	36	72	32	50	0,40	
11662400			4							
11660900		20	4	G 1"	36	72	32	50	0,52	
11661000			6,3							
11661100		25	10	G 1 1/4"	41	82	34	52	0,80	
11661200		32	16	G 1 1/2"	47	94	37	55	1,08	
11662100		40	25	G 2"	53	106	44	62	1,99	
11662300	50	35	G 2 1/4"	60	120	46	64	2,65		

### VRB143 Compression fitting

Art. No.	Reference	DN	Kvs	Connection	A	B	C	D	Weight [kg]	Note
11661500	VRB143	20	4	CPF 22 mm	36	72	32	50	0,40	
11661600			6,3							
11661700		25	6,3	CPF 28 mm	36	72	32	52	0,45	



### ADDITIONAL GUIDANCE

Accessories.....53, 88–89  
 Guide & Dimensioning.....54–55, 57, 59

Installation examples.....62  
 For further detailed information.....www.esbe.eu



## MIXING VALVE

### Series 3F, 4F

- **Superb regulation for best mixing or diverting performance up to 6 bar (PN6)**
- **Wide range of sizes up to DN150**
- **Long lasting and high durability**
- **Perfect match between the valve and ESBE actuators**

Series 3F and 4F are valves with flange connection PN6, suitable for mixing or diverting operation up to 6 bar. The valves are made of high-performing cast iron allowing use in heating and cooling installations. The F series is available in DN20-150 and comes with a PN6 flange to suit PN6 flange pipe dimensions. The valve is perfectly combined with ESBE actuators and controllers

#### TECHNICAL DATA

Pressure class: \_\_\_\_\_ PN 6  
 Media temperature: \_\_\_\_\_ max. 110°C, min. -10°C  
 Differential pressure drop, DN 20-50: \_\_\_\_\_ max. 50 kPa (0,5 bar)  
 DN 65-150: \_\_\_\_\_ max. 30 kPa (0,3 bar)  
 Leakrate in % of flow\*: \_\_\_\_\_ max. 1,5%  
 Rangeability Kv/Kv<sup>min</sup>: \_\_\_\_\_ 100  
 Connection: \_\_\_\_\_ Flange according to EN 1092-2  
 Media: \_\_\_\_\_ Heating water (in accordance with VDI2035)  
 \_\_\_\_\_ Water / Glycol mixtures, max. 50%\*\*  
 Material \_\_\_\_\_ DN 20-25 \_\_\_\_\_ DN 32-150  
 Valve body: \_\_\_\_\_ Cast iron EN-JL 1030  
 Slide: \_\_\_\_\_ brass CW 614N \_\_\_\_\_ brass CW 614N and stainless steel  
 Bushing: \_\_\_\_\_ plastic \_\_\_\_\_ brass CW 602N  
 Cover plate: \_\_\_\_\_ zinc \_\_\_\_\_ cast iron  
 O-rings: \_\_\_\_\_ EPDM

PED 2014/68/EU, article 4.3

\* Differential pressure 50 kPa (0,5 bar)  
 \*\* Additional guidance - page 54



3F



4F

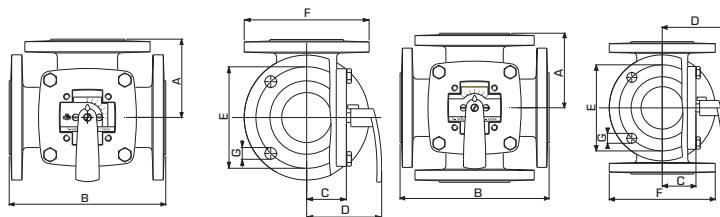

#### 3F Flange

Art. No.	Reference	DN	Kvs	A	B	C	D	E	F	G	Weight [kg]	Note
11100100	3F 20	20	12	70	140	40	82	65	90	4x11,5	3,5	
11100200	3F 25	25	18	75	150	40	82	75	100	4x11,5	4,0	
11100300	3F 32	32	28	80	160	40	82	90	120	4x15	5,9	
11100400	3F 40	40	44	88	175	40	82	100	130	4x15	6,8	
11100600	3F 50	50	60	98	195	50	92	110	140	4x15	9,1	
11100800	3F 65	65	90	100	200	52	95	130	160	4x15	10,0	
11101000	3F 80	80	150	120	240	63	106	150	190	4x18	16,2	
11101200	3F 100	100	225	132	265	73	116	170	210	4x18	21,0	
11101400	3F 125	125	280	150	300	80	123	200	240	8x18	27,0	
11101600	3F 150	150	400	175	350	88	130	225	265	8x18	37,0	

#### 4F Flange

Art. No.	Reference	DN	Kvs	A	B	C	D	E	F	G	Weight [kg]	Note
11101700	4F 32	32	28	80	160	40	82	90	120	4x15	7,0	
11101800	4F 40	40	44	88	175	40	82	100	130	4x15	8,2	
11101900	4F 50	50	60	98	195	50	92	110	140	4x15	11,0	
11102000	4F 65	65	90	100	200	50	92	130	160	4x15	12,2	
11102100	4F 80	80	150	120	240	65	108	150	190	4x18	20,0	
11102200	4F 100	100	225	132	265	81	124	170	210	4x18	25,0	
11102300	4F 125	125	280	150	300	81	124	200	240	8x18	35,0	
11102400	4F 150	150	400	175	350	89	131	225	265	8x18	45,0	



#### ADDITIONAL GUIDANCE

Accessories..... 88-89  
 Guide & Dimensioning..... 54-55, 58, 60

Installation examples..... 61  
 For further detailed information ..... [www.esbe.eu](http://www.esbe.eu)



**BUTTERFLY VALVE**

Series VBF100

- Energy saving - tight sealing and zero leakage (rate A)
- Adaptor kits available for easy adaptation to ESBE actuators

The ESBE series VBF100 are butterfly valves of wafer type designed for control and isolation of water in HVAC systems.

The valves are ready to be equipped with thermometers for temperature measurements, and can be motorized with ESBE actuators series 90, ARC300 and ARD100/ARD200 in combination with adaptors.

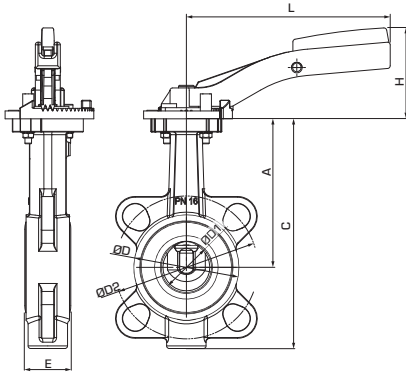

**TECHNICAL DATA**

Type: \_\_\_\_\_ 2-way valve  
 Pressure class: \_\_\_\_\_ PN 16  
 Flow characteristic A-AB: \_\_\_\_\_ see graph  
 Leakage rate A: \_\_\_\_\_ EN 12266, ISO 5208 category 3  
 Leakrate A-AB: \_\_\_\_\_ Tight sealing  
 $\Delta P_{max}$ : \_\_\_\_\_ see graph  
 Media temperature: \_\_\_\_\_ max. +130°C  
 \_\_\_\_\_ min. -20°C  
 Connection: \_\_\_\_\_ Flange PN 6/10/16, EN 1092  
 \_\_\_\_\_ Top flange, EN ISO 5211  
 Material  
 Body: \_\_\_\_\_ Grey Cast Iron GG25, 0.6025  
 Shaft: \_\_\_\_\_ Stainless steel X14CrMoS17, 1.4104/  
 \_\_\_\_\_ X5CrNiMo17-12-2, 1.4401/  
 \_\_\_\_\_ Hastelloy, 2.4883  
 Disc: \_\_\_\_\_ Stainless steel G-X6CrNiMo18-10, 1.4408 A  
 Seat: \_\_\_\_\_ EPDM  
 Bearing bush: \_\_\_\_\_ Brass MS 58, 2.0401/  
 \_\_\_\_\_ Polyamide PA66 / PTFE  
 O-ring: \_\_\_\_\_ NBR / FPM

**VBF125 Flange**

Art. No.	Reference	DN	Kvs	A	C	D	D1	D2		E	H	L	Replaces	Weight [kg]
								PN6	PN16					
13900100	VBF125	20	32	104	149	59	31,5	65	75	33	70	155	MA20	1,5
13900200		25	36	104	149	63	31,5	75	85	33	70	155	MA25	1,5
13900300		32	40	104	154	68	31,5	90	100	33	70	155	MA30	1,6
13900400		40	50	113	179	80	38,0	100	110	33	70	155	MA40	2,0
13900500		50	85	126	210	95	48,5	110	125	43	70	155	MA50	2,4
13900600		65	215	134	227	115	63,5	130	145	46	70	155	MA65	3,1
13900700		80	420	157	261	138	78,5	150	160	46	80	195	MA80	4,2
13900800		100	800	167	282	158	98,5	170	180	52	80	195	MA100	5,4
13900900		125	1010	180	307	188	123,5	200	210	56	80	195	MA125	7,1
13901000		150	2100	203	353	212	148,0	225	240	56	100	276	MA150	10,1
13901100		200	4000	228	404	268	199,0	280	295	60	100	276	MA200	13,8



**ACCESSORIES** Thermometers

Art. No.	Reference	DN	Note
13906000	VBF806	20-32	
13906100		40	
13906200		50-65	
13906300		80-125	
13906400		150-200	



**ADDITIONAL GUIDANCE**

Accessories..... 88  
 Guide & Dimensioning..... 54, 56, 58, 60

Installation examples..... 63  
 For further detailed information ..... [www.esbe.eu](http://www.esbe.eu)





Flexible rotation 360 degrees + Flexible configuration 90–125 mm

## MIXING VALVE

### Series VRH130

- Adjustable parallel dimension
- Revolvable 180° axes allows angled installations
- Prevents from installation errors
- Line directional changes possible

Series VRH130 is a compact, flexible, low leakage mixing valve designed for installations where space is limited, and is made of high performance brass alloy, PN10. Available with pump flange in combination with external thread connections in DN20.

#### TECHNICAL DATA

Pressure class: \_\_\_\_\_ PN 10  
 Media temperature: \_\_\_\_\_ max. (continuously) 110°C  
 \_\_\_\_\_ max. (temporarily) 130°C  
 \_\_\_\_\_ min. -10°C  
 Torque (at nominal pressure): \_\_\_\_\_ < 3 Nm  
 Leakrate in % of flow\*: \_\_\_\_\_ Mixing, < 0,05%  
 \_\_\_\_\_ Diverting, < 0,02%  
 Working pressure: \_\_\_\_\_ 1 MPa (10 bar)  
 Max. differential pressure drop: \_\_\_\_\_ Mixing, 100 kPa (1 bar)  
 \_\_\_\_\_ Diverting, 200 kPa (2 bar)  
 Close off pressure: \_\_\_\_\_ 200 kPa (2 bar)  
 Rangeability Kv/Kv<sup>min</sup>, A-AB: \_\_\_\_\_ 100  
 Connections: \_\_\_\_\_ External thread (G), ISO 228/1  
 Media: \_\_\_\_\_ Heating water (in accordance with VDI2035)  
 \_\_\_\_\_ Water / Glycol mixtures, max. 50%\*\*  
 \_\_\_\_\_ Water / Ethanol mixtures, max. 28%

Material  
 Valve body, T-piece, connectors: \_\_\_\_\_ Dezincification resistant brass, DZR  
 Slide shoe: \_\_\_\_\_ Abrasion resistant brass  
 Shaft and bushing: \_\_\_\_\_ PPS composite  
 O-rings: \_\_\_\_\_ EPDM

PED 2014/68/EU, article 4.3

\* Differential pressure 100 kPa (1 bar)  
 \*\* Additional guidance - page 54

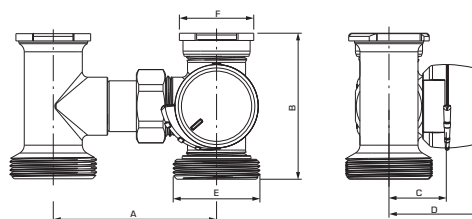

#### VRH139 External thread and Pump flange

Art. No.	Reference	DN	Kvs	Connection		A	B	C	D	Weight [kg]	Note
				E	F						
11720100	VRH139	20	2,5	G 1 1/2"	PF 1 1/2"	90 - 125	80	32	50	1,20	
11720200			4								
11720300			6,3								



#### ADDITIONAL GUIDANCE

Accessories..... 88–89  
 Guide & Dimensioning..... 54–55, 57, 59

For further detailed information ..... [www.esbe.eu](http://www.esbe.eu)



**MIXING VALVE**

Series HG

- **Superb regulation for best mixing or double mixing performance**
- **Compact and easy to install**
- **Long lasting and high durability**
- **Bypass available**
- **Perfect match between the valve and ESBE actuators**

Series HG are 3-way and 4-way control valves for pump flange connections suitable for mixing and double mixing operations in parallel applications. The valves are made of high-performing cast iron allowing use in heating installations. The HG series is available in DN25 and comes with pump flange connection. The valve is perfectly combined with ESBE actuators and controllers.

**TECHNICAL DATA**

Pressure class: \_\_\_\_\_ PN 10  
 Temperature: \_\_\_\_\_ max. 110°C  
 \_\_\_\_\_ min. -10°C  
 Differential pressure drop: \_\_\_\_\_ max. 50 kPa (0,5 bar)  
 Torque: \_\_\_\_\_ 5 Nm  
 Leakrate in % of flow\*: \_\_\_\_\_ max. 1%  
 Connections: \_\_\_\_\_ External thread (G), ISO 228/1  
 Media: \_\_\_\_\_ Heating water (in accordance with VDI2035)  
 \_\_\_\_\_ Water / Glycol mixtures, max. 50%\*\*

Material  
 Body: \_\_\_\_\_ Cast iron EN-JL 1030  
 Slide/Spindle: \_\_\_\_\_ Brass CW 614N  
 Bushing: \_\_\_\_\_ Plastic  
 Cover plate: \_\_\_\_\_ Zinc  
 O-rings: \_\_\_\_\_ EPDM

PED 2014/68/EU, article 4.3

\* Differential pressure 50 kPa (0,5 bar)  
 \*\* Additional guidance - page 54



**3HG** External thread and Pump flange

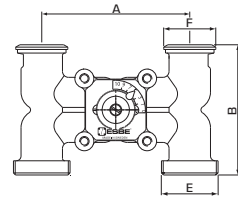
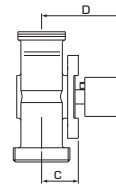

Art. No.	Reference	DN	Kvs	A	B	C	D	Connection		Weight [kg]	Note
								E	F		
11350500	3HG25-125	25	10	125	110	38	76	G 1/2"	PF 1/2"	2,0	1)
11351200										2,2	1), 2)



**4HG** External thread and Pump flange

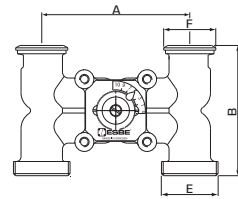
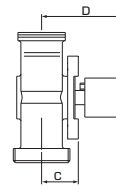

Art. No.	Reference	DN	Kvs	A	B	C	D	Connection		Weight [kg]	Note
								E	F		
11350100	4HG25-90	25	8	90	110	38	76	G 1 1/2"	PF 1 1/2"	1,5	1)
11350200			6,3							1,8	1)
11350800	4HG25-125	25	10	125	110	38	76	G 1 1/2"	PF 1 1/2"	2,0	1)
11351100										10	2,2



**ADDITIONAL GUIDANCE**

Accessories..... 88–89  
 Guide & Dimensioning..... 55, 59

For further detailed information ..... [www.esbe.eu](http://www.esbe.eu)

Note 1) Male thread for union connections 2) With By-pass



## MIXING VALVE

### Series 5MG

- **Superb regulation for best stratification of storage tanks**
- **Long lasting and high durability**
- **Perfect match between the valve and ESBE actuators**

Series 5MG are 5-way valves suitable for stratification of storage tanks. The valves are made of high-performing brass allowing use in heating installations. The 5MG series is available in DN25-32 and comes with one type of connection. The valve is perfectly combined with ESBE actuators.

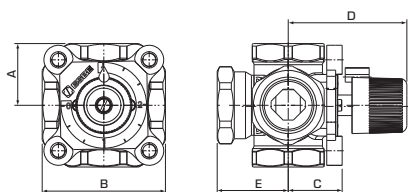

**5MG** Internal thread

Art. No.	Reference	DN	Kvs	Connection	A	B	C	D	E	Weight [kg]	Leakrate in % of flow	Note
11005200	5MG25	25	8	Rp 1"	36	72	32	70	41	0,9	0,3	
11005300	5MG32	32	18	Rp 1 1/4"	44	88	38	77	47	1,2	0,2	

#### TECHNICAL DATA

Pressure class: \_\_\_\_\_ PN 10  
 Media temperature: \_\_\_\_\_ max. +130°C  
 \_\_\_\_\_ min. -10°C  
 Differential pressure drop: \_\_\_\_\_ max. 100 kPa (1 bar)  
 Torque: \_\_\_\_\_ max. 3Nm  
 Leakrate in % of flow\*: \_\_\_\_\_ see table  
 Rangeability Kv/Kv<sup>min</sup>: \_\_\_\_\_ 100  
 Connections: \_\_\_\_\_ Internal thread (Rp), EN 10226-1  
 Media: \_\_\_\_\_ Heating water (in accordance with VDI2035)  
 \_\_\_\_\_ Water / Glycol mixtures, max. 50%\*\*

Material  
 Valve body, spindle and slide: \_\_\_\_\_ Brass CW 614N  
 Bushing: \_\_\_\_\_ Plastic  
 Cover plate: \_\_\_\_\_ Zinc  
 O-rings: \_\_\_\_\_ EPDM

PED 2014/68/EU, article 4.3

\* Differential pressure 50 kPa (0,5 bar)  
 \*\* Additional guidance - page 54



#### ADDITIONAL GUIDANCE

Guide & Dimensioning.....54–55, 59  
 Installation examples..... 62

For further detailed information ..... [www.esbe.eu](http://www.esbe.eu)



## MIXING VALVE

### Series T and TM

- **Superb regulation for best double mixing performance up to 6 bar (PN6).**
- **Compact, and easy to install on boilers**
- **Long lasting and high durability**
- **Perfect match between the valve and ESBE actuators**

Series T are 4-way valves for factory assembly on boilers and is suitable for double mixing operation up to 6 bar. The valves are made of high-performing cast iron allowing use in boiler installations. The T series is available in DN20-25 and comes with one type of connection. The valve is perfectly combined with ESBE actuators and controllers.

Series TM are 4-way valves for factory assembly on boilers and is suitable for double mixing operation up to 10 bar. The valves are made of high-performing brass allowing use in boiler installations. The TM series is available in DN20-25 and comes with two types of connections to suit most pipe dimensions. The valve is perfectly combined with ESBE actuators and controllers.

#### TECHNICAL DATA

Pressure class: \_\_\_\_\_ Series T, PN 6  
 \_\_\_\_\_ Series TM, PN 10  
 Media temperature: \_\_\_\_\_ max. 110°C, min. -10°C  
 Differential pressure drop: \_\_\_\_\_ max. 50 kPa (0,5 bar)  
 Operation angle: \_\_\_\_\_ 90°  
 Torque: \_\_\_\_\_ Series T, 5 Nm  
 \_\_\_\_\_ Series TM, 3 Nm  
 Leakrate in % of flow\*: \_\_\_\_\_ max. 1,5%  
 Connections: \_\_\_\_\_ Internal thread (Rp), EN 10226-1  
 \_\_\_\_\_ External thread (G), ISO 228/1  
 \_\_\_\_\_ Compression fitting (CPF), EN 1254-2  
 Media: \_\_\_\_\_ Heating water (in accordance with VDI2035)  
 \_\_\_\_\_ Water / Glycol mixtures, max. 50%\*\*  
 Material  
 Body: Series T \_\_\_\_\_ Cast iron EN-JL 1030  
 Series TM \_\_\_\_\_ Brass CW 614N  
 Slide/Spindle: \_\_\_\_\_ Brass CW 614N  
 Bushing: \_\_\_\_\_ Plastic  
 Cover plate: \_\_\_\_\_ Zinc  
 O-rings: \_\_\_\_\_ EPDM

PED 2014/68/EU, article 4.3

\* Differential pressure 50 kPa (0,5 bar)  
 \*\* Additional guidance - page 54

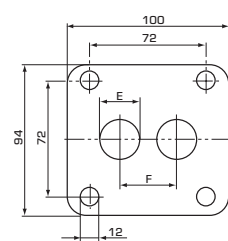
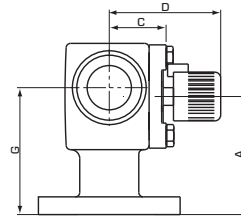
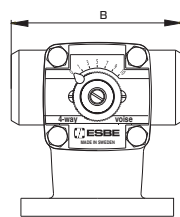

**T** Internal thread

Art. No.	Reference	DN	Kvs	Connection	A	B	C	D	E	F	G	Weight [kg]	Note
11300900	T20	20	8	Rp 3/4"	80	115	39	76	20	35	86	2,7	
11301000	T25	25	10	Rp 1"	80	115	39	76	25	35	86	2,7	

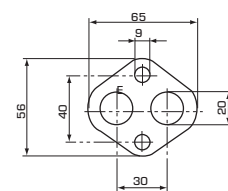
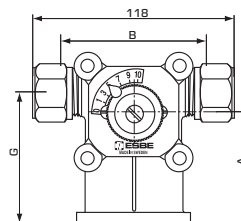
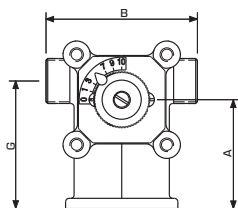

11300400

11300600/11300700

11300400

11300600/11300700

**TM** External thread

Art. No.	Reference	DN	Kvs	Connection	A	B	C	D	G	Weight [kg]	Note
11300400	TM20	20	5,5	G 3/4"	64	85	39	76	75	0,90	

**TM** Compression fitting

Art. No.	Reference	DN	Kvs	Connection	A	B	C	D	G	Weight [kg]	Note
11300600	TM20	20	5,5	CPF 22mm	64	85	39	76	75	1,14	G 1/2" in base connection
11300700											



#### ADDITIONAL GUIDANCE

Guide & Dimensioning ..... 55

For further detailed information ..... [www.esbe.eu](http://www.esbe.eu)



## INSULATION SHELL

### Series VRI100

- Insulation according to **EnEV2014**
- Reduce heatlosses by **65%**
- Shells specially designed for **ESBE valves and offering a tight seal**
- Avoid burning injuries from hot valves

Series VRI100 is a range of insulations shells for the valve series VRG and VRB and is available for sizes DN15-DN40. The insulations shells is developed according to the directive EnEV2014 and offers a tight seal around the valve to air-circulations and heat-losses. The shell is designed with a strong self-locking function and there is no need of extra accessories, like tape or springs, to keep the two shells together.

#### TECHNICAL DATA

Media temperature: \_\_\_\_\_ max. +130°C  
 \_\_\_\_\_ min. -20°C  
 Ambient temperature: \_\_\_\_\_ max. +130°C  
 \_\_\_\_\_ min. -20°C  
 Material: \_\_\_\_\_ EPP black 35g/l  
 λ coefficient: \_\_\_\_\_ 0,035 W/mK



EnEV2014

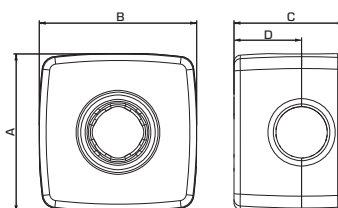

Art. No.	Reference	DN	A	B	C	D	Note
16103800	VRI111	15/20	95	95	72	40	
16103900		25	117	117	84	50	
16104000		32	120	120	92	55	
16104100		40	160	160	114	70	



## CONNECTION KIT

### Series KTD100

#### VERSIONS

Each package contains three of each of connection pieces, nuts and gaskets.

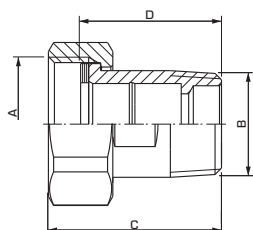

#### TECHNICAL DATA

Pressure class: \_\_\_\_\_ PN10  
 Media temperature: \_\_\_\_\_ max. +180°C  
 \_\_\_\_\_ min. -20°C  
 Connection - nipple design: \_\_\_\_\_ acc. to EN 1254-4  
 \_\_\_\_\_ Internal thread (G), ISO 228/1  
 \_\_\_\_\_ External thread (R), EN 10226-1

Material  
 Nut: \_\_\_\_\_ Brass CW 614N  
 Connection piece: \_\_\_\_\_ Dezincification resistant brass, DZR\*  
 Gasket: \_\_\_\_\_ Klingersil C-4400

\* Suitable for drinking water applications

PED 2014/68/EU, article 4.3

Art. No.	Reference	Connection		Dimension		Weight [kg]	Note
		A	B	C	D		
36551700	KTD112	G 1"	R ¾"	43	35	0,36	
36551800		G 1¼"	R 1"	48,5	40	0,63	
36551900		G 1½"	R 1¼"	55,5	45	0,97	
36552000		G 2"	R 1½"	62	50	1,32	
36552100		G 2¼"	R 2"	68	55	2,18	



#### ADDITIONAL GUIDANCE

For further detailed information ..... [www.esbe.eu](http://www.esbe.eu)



## ROTARY VALVES SELECTION GUIDE

### HOW TO SELECT A ROTARY MIXING VALVE

ESBE 3-way mixing valves are usually connected as a mixing valve, but it may also be used as a change-over valve or diverting valve.

If high return temperature is required (mostly solid fuel installations) a 4-way mixing valve is recommended. In all other applications/installations a 3-way valve is preferred.

In systems with two heat sources or storage tanks, the VRB-valve helps to prioritize the cheapest energy source and keeps a good temperature stratification in the storage tank.

### FIELDS OF APPLICATION

- 1) Control of (fluid) water based systems for heating and cooling: radiator heating, floor heating and other surface heating and cooling systems.
- 2) Change-over or diverting valve (only 3-way valves).

Make sure that the nominal pressure, the differential pressure as well as the leak rate are within acceptable values. This information is stated for each valve.

### SELECTION OF MIXING VALVE SIZE

Each size of mixing valve has a Kvs-value (capacity in m<sup>3</sup>/h at a pressure drop of 1 bar) stated. It is the Kvs-value as well as the system the valve serves that decides which valve to choose. For a radiator system  $\Delta t = 20^{\circ}\text{C}$  is usually chosen and for under floor heating  $\Delta t = 5^{\circ}\text{C}$ .

Suitable pressure drop should be in the range 3–15 kPa. As a rule of thumb, the lowest Kvs-value is chosen, if there are two alternatives within the pressure drop range.

### MATERIAL/MEDIA

Valve series VRG, VRB and 5MG are made of a special brass alloy (DZR). ESBE's other series of mixing valves may only be used in closed systems where the water is not oxygenated.

A maximum of 50% glycol for freezing protection and oxygen absorbing compounds are allowed as additives. As both the viscosity and the thermal conduction are affected when glycol is added to the system water, this fact has to be considered when dimensioning the valve. A good rule is to choose one size higher Kv-value when 30 - 50 % glycol is added. A lower concentration of glycol does not affect the valve performance.

### OPERATION 3-WAY VALVES

VRG130, 330

The required system temperature is obtained by adding a suitable proportion of return water to the boiler flow.

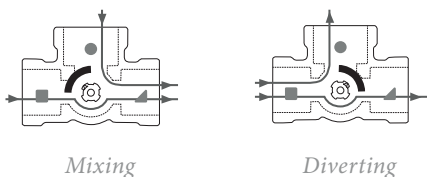

VRG230

Valves with special design of the inner parts, suitable for applications which requires mid-port changeover operation. Can be placed in both diverting and mixing positions.

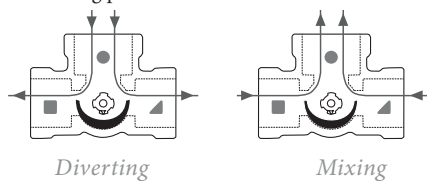

### OPERATION 4-WAY VALVES

VRG140

The valves have a double mixing function, i.e. a proportion of the hot water supplied from the boiler is mixed with the return water. This results in a higher return water temperature, reducing the risk of corrosion and assuring a longer life for the boiler.

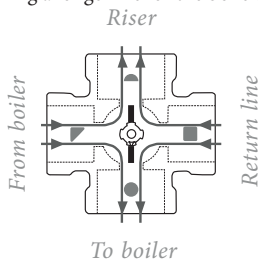

### OPERATION 5-WAY VALVES

5MG

Mixing valve with 4 inlets for use in systems with three heat sources or three layers in a storage tank.

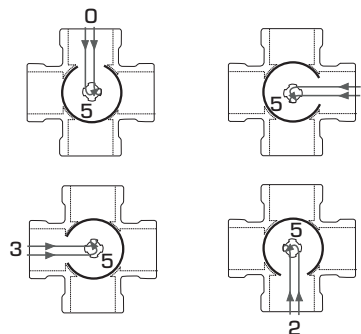

### OPERATION BIVALENT VALVES

VRB140

Mixing valve with 3 inlets for use in systems with two heat sources or two layer storage tank.

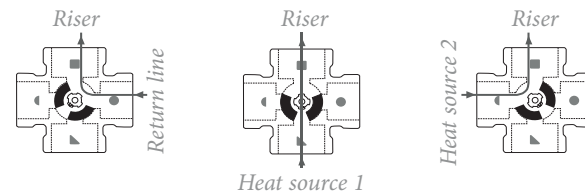

# ROTARY VALVES DIMENSIONING

## HEATING SYSTEMS (RADIATOR OR UNDERFLOOR HEATING SYSTEMS)

Start with the heat demand in kW (e.g. 25 kW) and move vertically to the chosen  $\Delta t$  (e.g. 15°C).

Move horizontally to the shaded field (pressure drop of 3-15 kPa) and select the smaller Kvs-value (e.g. 4,0/6,3). A mixing valve with suitable Kvs-value will be found in respective product description.

## OTHER APPLICATIONS

Make sure maximum  $\Delta P$  is not exceeded (see lines A to E in the graphs below).

### SERIES VRx

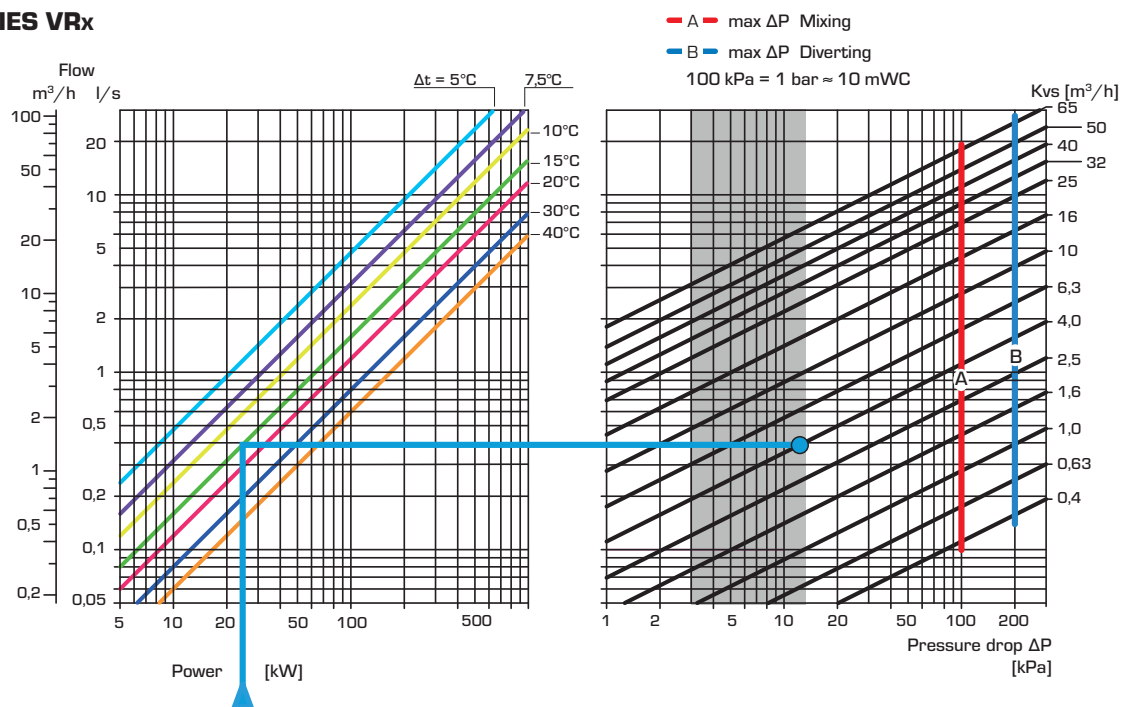

### SERIES MG, F, T/TM AND H/HG

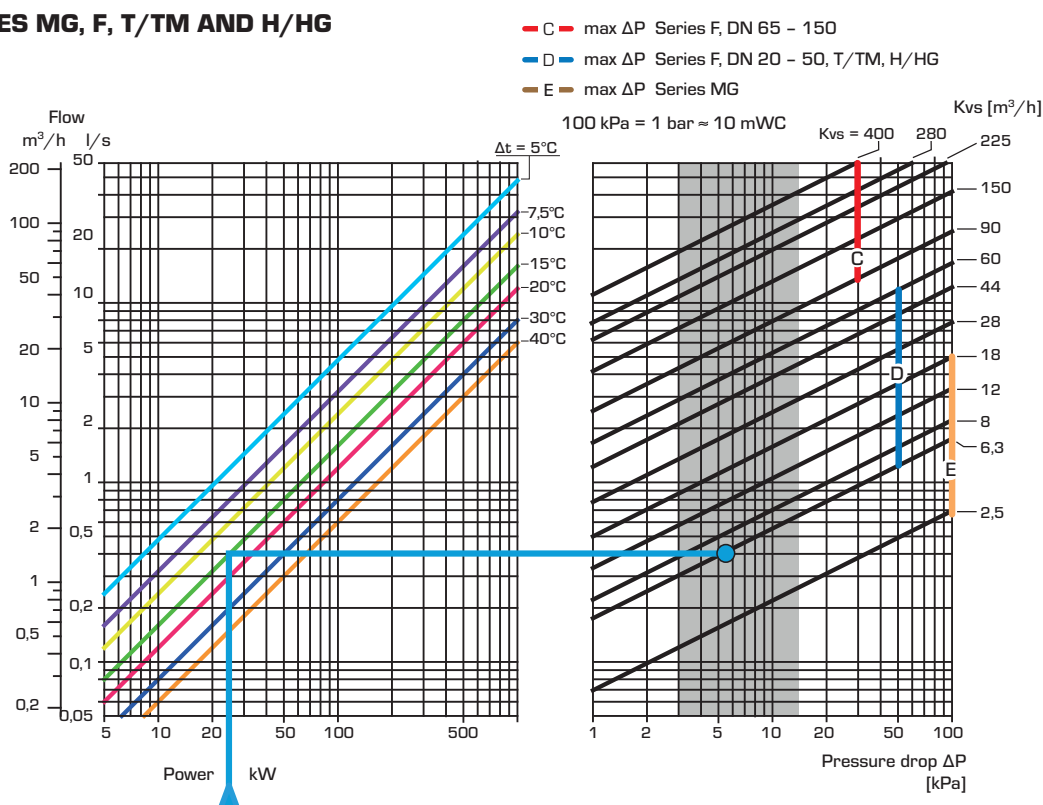

# ROTARY VALVES DIMENSIONING

## SERIES VBF100

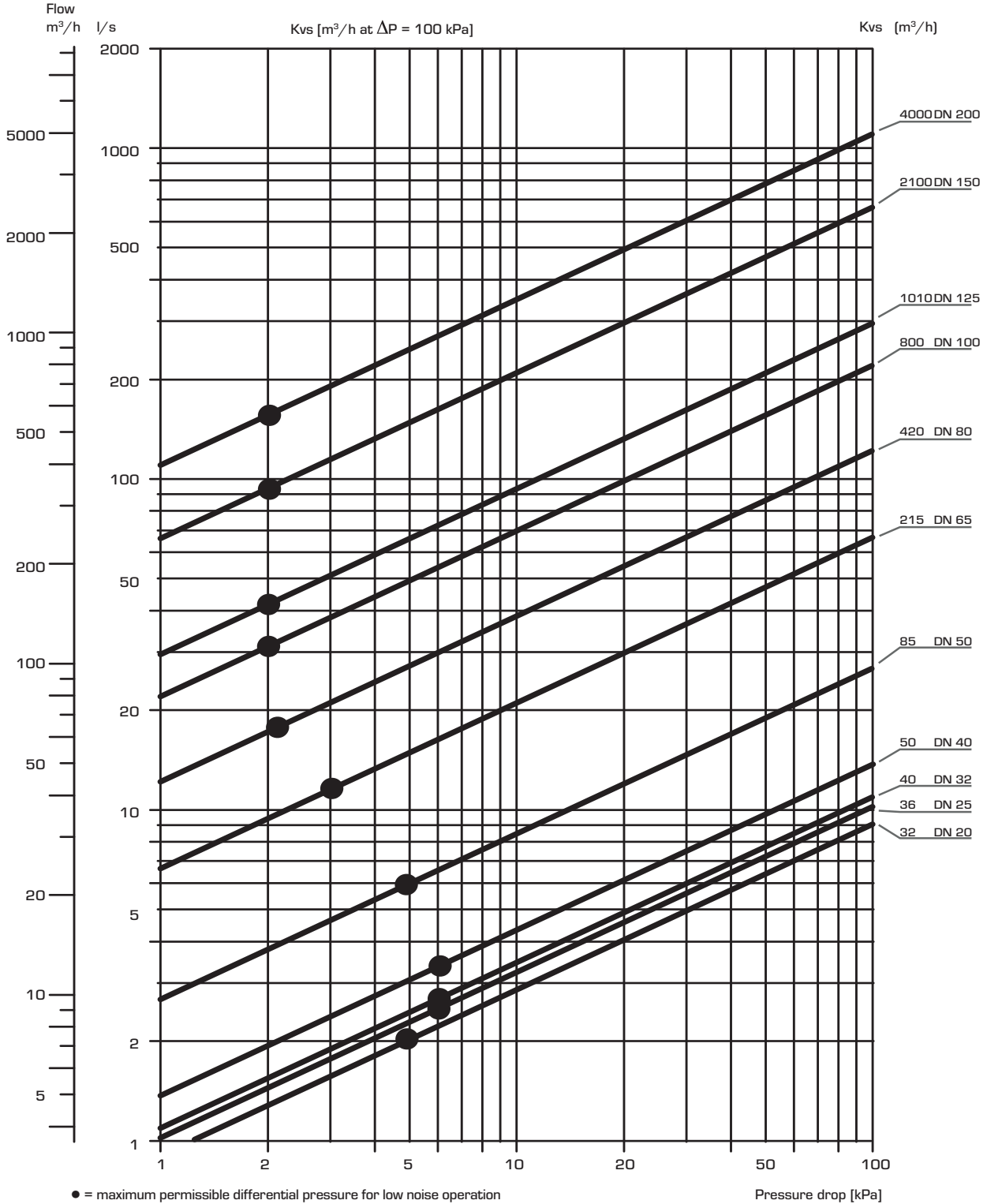

To be considered: As both the viscosity and the thermal conduction are affected when glycol is added to the system water, this fact has to be considered when dimensioning the valve. A good rule is to choose one size higher Kv-value when 30 - 50% glycol is added. A lower concentration of glycol may be disregarded. N.B.! Maximum 50% glycol for freezing protection and oxygen absorbing compounds are allowed as additives.

# ROTARY VALVES

## VALVE CHARACTERISTICS

### SERIES VRG130, VRH130

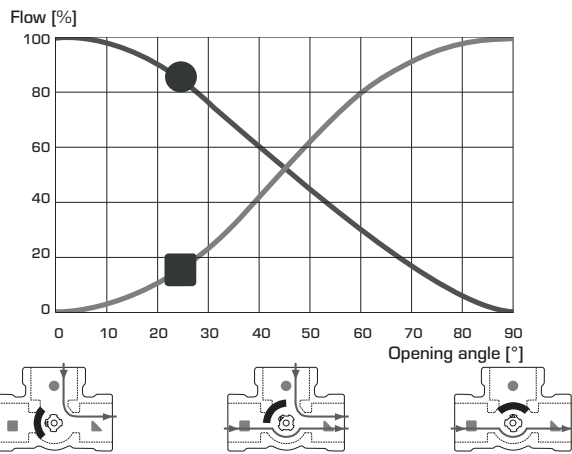

### SERIES VRG230

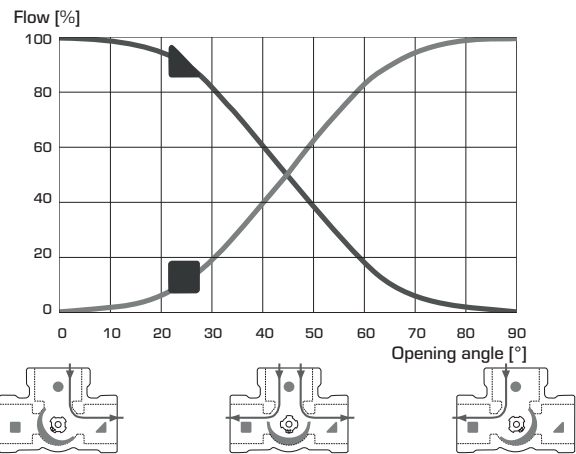

### SERIES VRG330

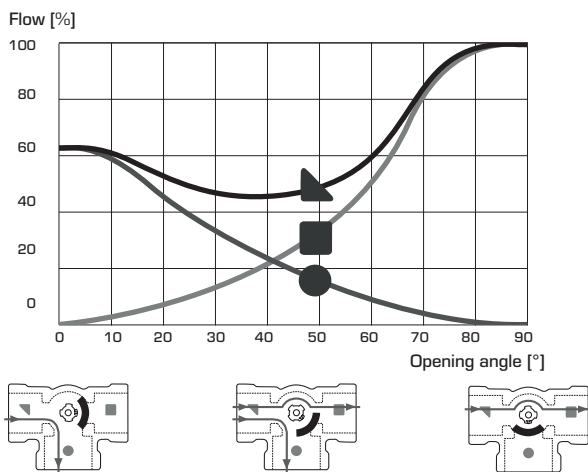

### SERIES VRG140

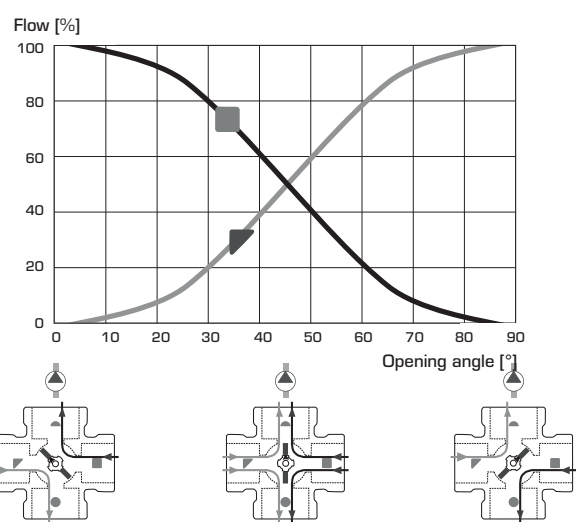

### SERIES VRB140

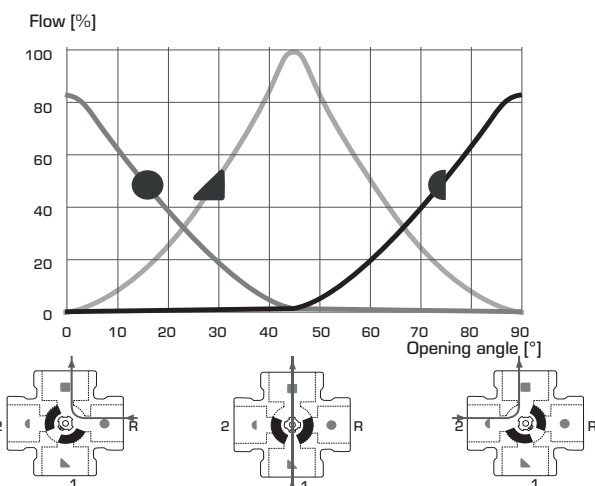

# ROTARY VALVES

## VALVE CHARACTERISTICS

### SERIES 3F

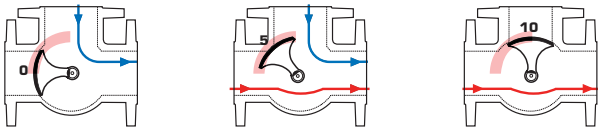
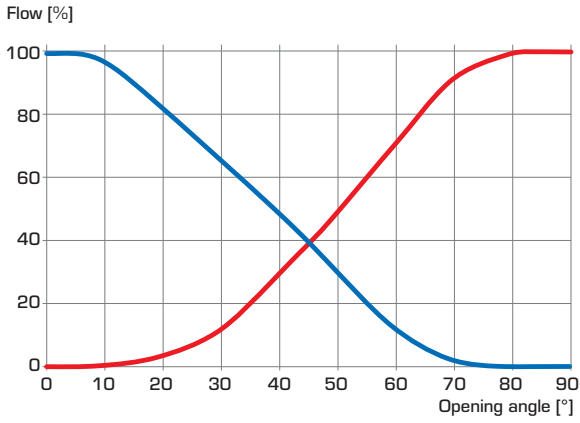

### SERIES 4F

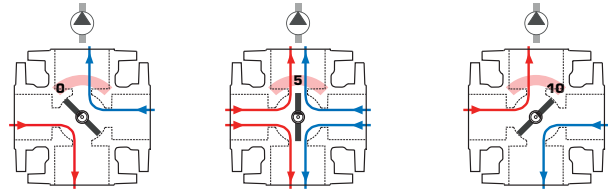
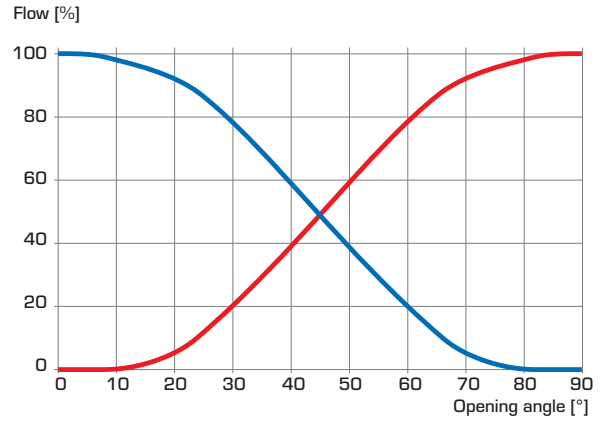

### SERIES VBF100

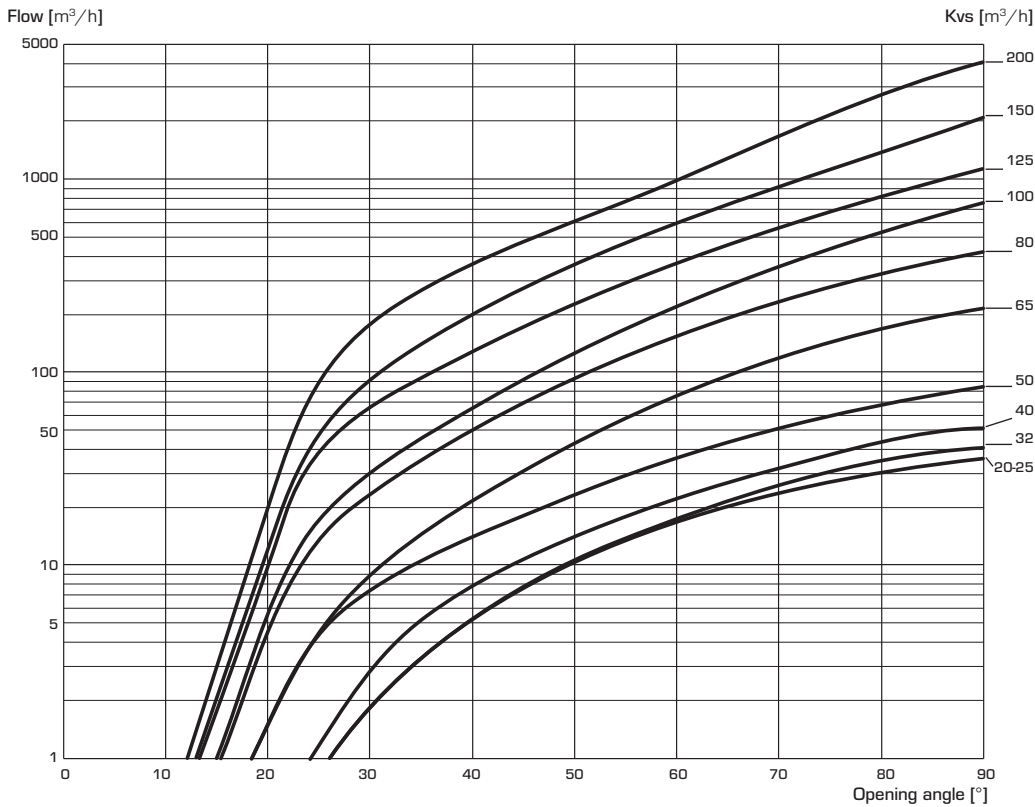









# ROTARY VALVES + ACTUATORS/CONTROLLERS

## SELECTION GUIDE

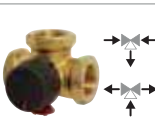
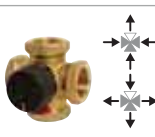
● Recommended    ● Secondary alternative

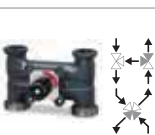
	Actuators						Controllers				
	ARAGxx			90			90C	CRA11x, CRA14x, CRA15x	CRB11x, CRB12x	CRA12x	CRS13x
	3-P	2-P	Prop.	3-P	2-P	Prop.		CRC11x, CRC14x	CRD12x	CRC12x	
 VRG130											
 VRG330	●	●	●	●*	●*	●*	●		●	●*	● <sup>1)</sup>
 VRH130											
 VRG140	●	●	●	●*	●*	●*	●		●	●*	● <sup>1)</sup>
 VRG230	●	●	●	●*	●*	●*	●		●	●*	● <sup>1)</sup>
 VRB140	●		●	●*		●*	●		●	●*	● <sup>1)</sup>
 5MG				●**		●**					
 3HG, 4HG	●	●	●				●		●		

Notes: \*Additional adaptor kit necessary, see pages 88-89 \*\* Only type 95-270M and 92P4 <sup>1)</sup> Due to drinking water legislation shall decision of valve be made depending on application and national laws and directives.

## ROTARY VALVES + ACTUATORS/CONTROLLERS SELECTION GUIDE

● Recommended    ● Secondary alternative

	Actuators									Controllers	
	90 - 15 Nm			ARC300 - 30 Nm		ARD100 - 10 Nm		ARD200 - 20 Nm		90C	CRA12x CRC12x
	3-P	2-P	Prop.	3-P/2-P	Prop.	2-P	Prop.	2-P	Prop.		
 3F	●	●	●	●	●	●	●	●	●	●	●
	≤ DN100			≤ DN150		≤ DN80		≤ DN150		≤ DN100	≤ DN100
 4F	●	●	●	●	●	●	●	●	●		●
	≤ DN100			≤ DN150		≤ DN80		≤ DN150			≤ DN100
 Damper				●	●	●	●	●	●		
				6 m <sup>2</sup> □ 9 - 18 mm ○ 9 - 26 mm		2 m <sup>2</sup> □ 9 - 18 mm ○ 9 - 26 mm		4 m <sup>2</sup> □ 9 - 18 mm ○ 9 - 26 mm			

		Actuators				
		90 - 15 Nm	ARC300 - 30 Nm	ARC600 - 60 Nm	ARD100 - 10 Nm	ARD200 - 20 Nm
	DN	Adaptor kit	Adaptor kit	Adaptor kit	Adaptor kit	Adaptor kit
 VBF125	20	13905100			13905200	13905200
	25					
	32					
	40					
	50					
	65					
	80		13905200	13905200		
	100					
	125					
	150					
200						

# ROTARY VALVES + ACTUATORS

## INSTALLATION EXAMPLES

● Recommended    ● Secondary alternative    ○ Not applicable

Note: The illustrations always shows the mid position of the valve.

### INSTALLATION EXAMPLES ARE VALID FOR

<p>● VRG130    ○ VRG140    ○ VRG230    ● VRG330    ○ VRB140    ○ 5MG    ● 3F    ○ 4F</p>			
<p>①</p>	<p>②</p>	<p>③</p>	<p>④</p>
<p>● VRG130    ○ VRG140    ○ VRG230    ○ VRG330    ○ VRB140    ○ 5MG    ○ 3F    ○ 4F</p>			
<p>⑤</p>	<p>⑥</p>	<p>⑦</p>	
<p>● VRG130    ○ VRG140    ○ VRG230    ● VRG330</p> <p>○ VRB140    ○ 5MG    ● 3F    ○ 4F</p>		<p>○ VRG130    ● VRG140    ○ VRG230    ○ VRG330</p> <p>○ VRB140    ○ 5MG    ○ 3F    ● 4F</p>	
<p>⑧</p>	<p>⑨</p>		

## ROTARY VALVES + ACTUATORS INSTALLATION EXAMPLES

● Recommended    ● Secondary alternative    ○ Not applicable

Note: The illustrations always shows the mid position of the valve.

### INSTALLATION EXAMPLES ARE VALID FOR

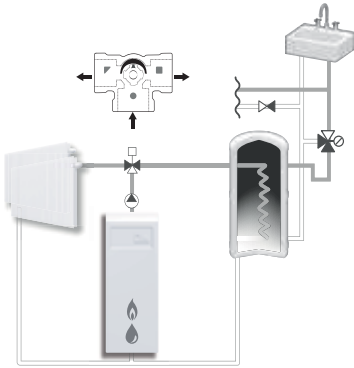
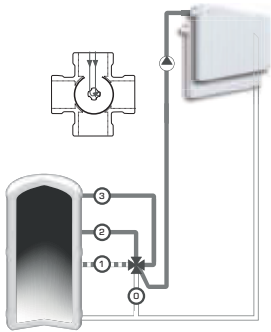
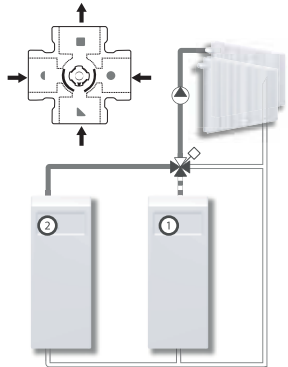
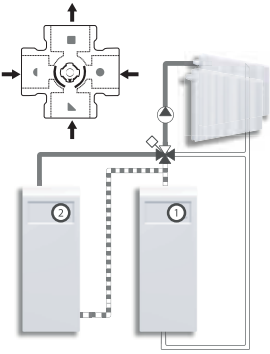
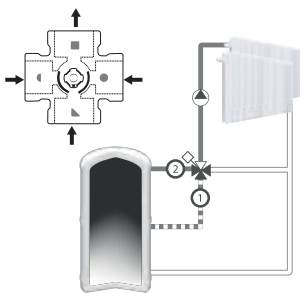
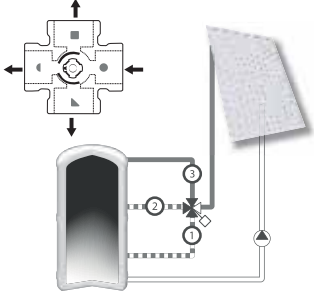
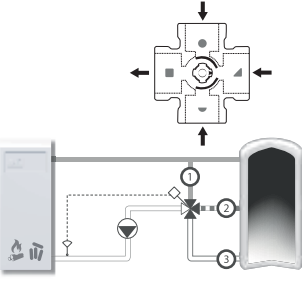
<p>○ VRG130    ○ VRG140    ● VRG230    ● VRG330 ○ VRB140    ○ 5MG    ○ 3F    ○ 4F</p> <p>①</p> 	<p>○ VRG130    ○ VRG140    ○ VRG230    ○ VRG330 ○ VRB140    ● 5MG    ○ 3F    ○ 4F</p> <p>②</p> 	
<p>○ VRG130    ○ VRG140    ○ VRG230    ○ VRG330    ● VRB140    ○ 5MG    ○ 3F    ○ 4F</p> <p>③</p> 	<p>④</p> 	<p>⑤</p> 
<p>⑥</p> 	<p>⑦</p> 	

# ROTARY VALVES + ACTUATORS/CONTROLLERS INSTALLATION EXAMPLES

INSTALLATION EXAMPLES ARE VALID FOR

● VBF100

①

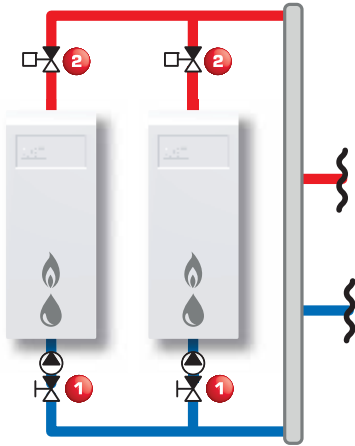

① VBF125

② VBF125 + 90/ARC/ARD

②

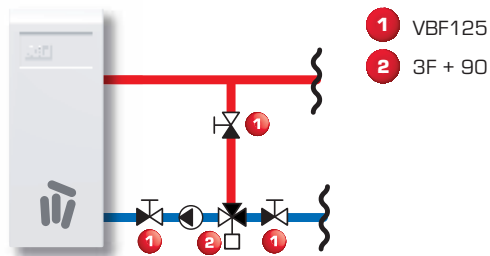

① VBF125

② 3F + 90

SERIES CRA110/CRA120

①

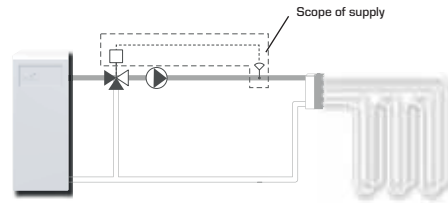

SERIES CRA110/CRA120

②

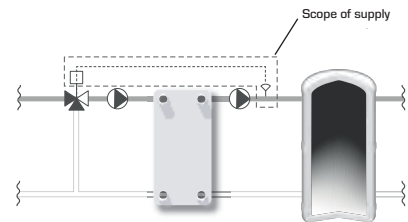

SERIES CRA110/CRA120

③

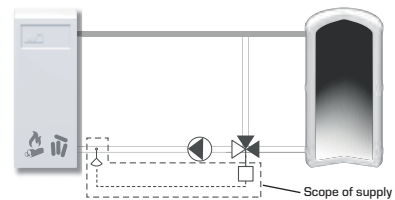

SERIES CRA110/CRA120

④

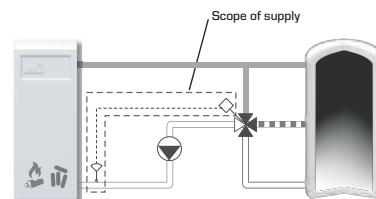



## ROTARY VALVES + CONTROLLERS INSTALLATION EXAMPLES

**SERIES CRA140**

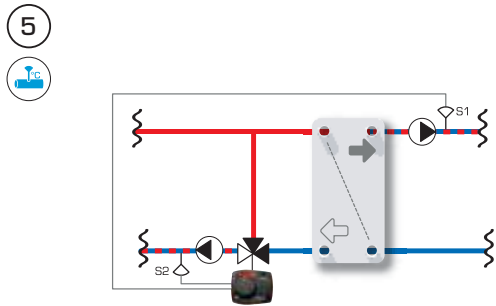

**SERIES CRC110**

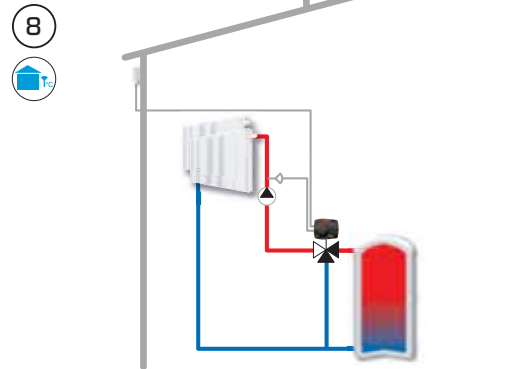

**SERIES CRA140**

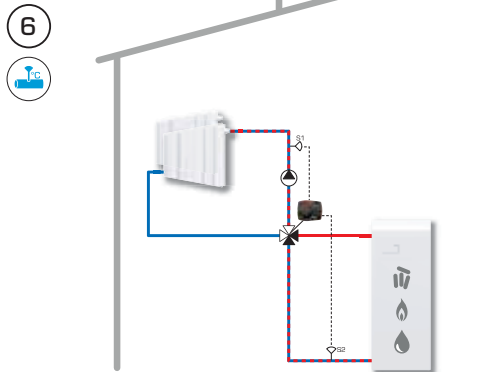

**SERIES CRC120**

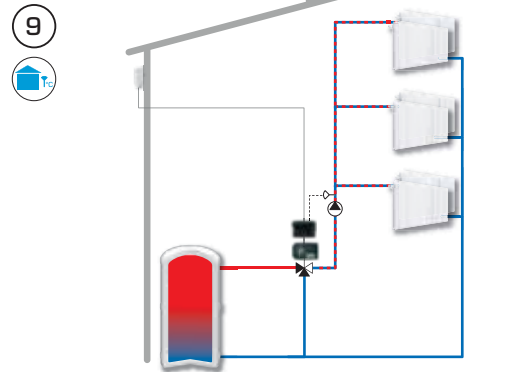

**SERIES CRA150**

*Heating mode*

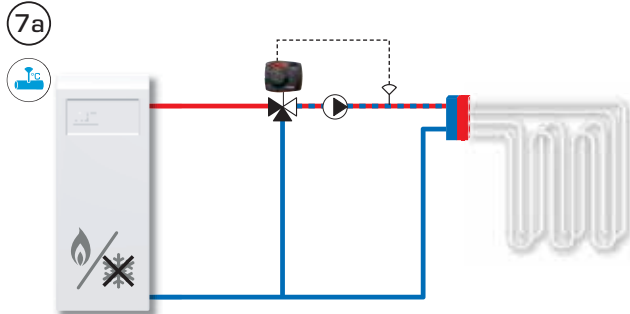

**SERIES CRC140**

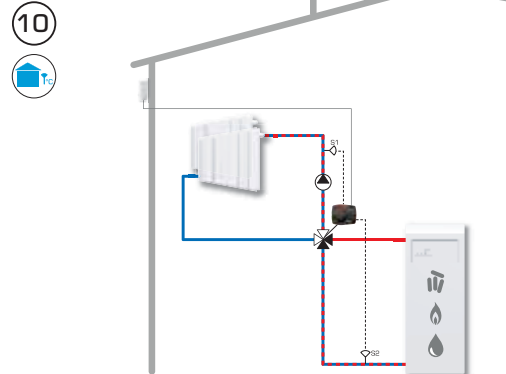

**SERIES CRA150**

*Cooling mode*

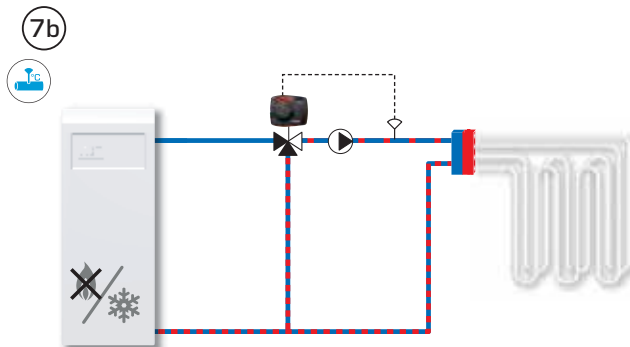

**SERIES CRC140**

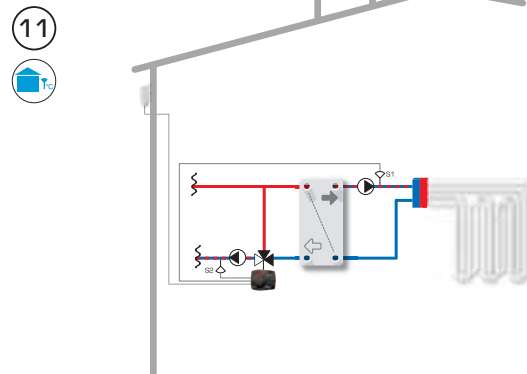

# ROTARY VALVES + CONTROLLERS

## INSTALLATION EXAMPLES

### SERIES CRD

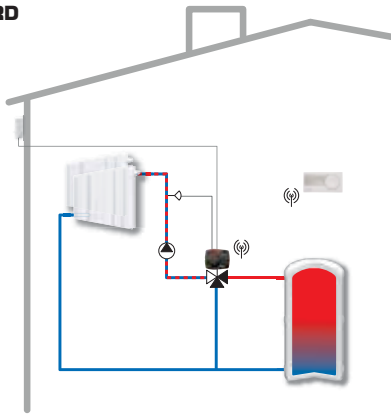

### SERIES CRD

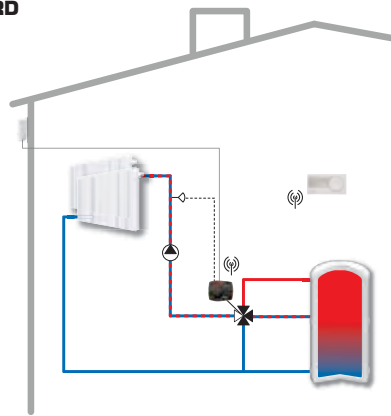

### SERIES CRB

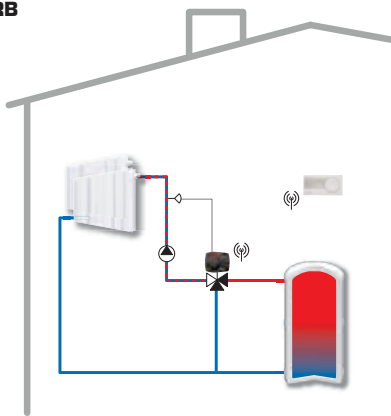

### SERIES CUA

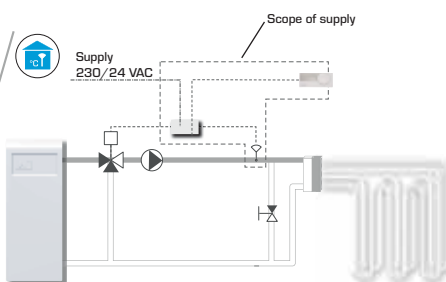

### SERIES CRS

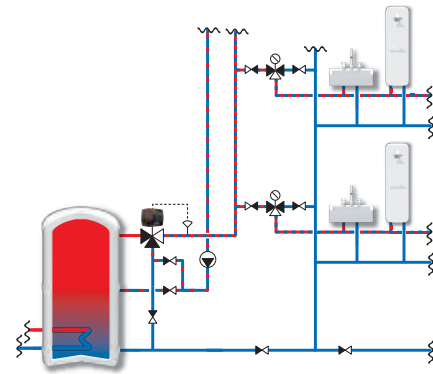

### SERIES CRS

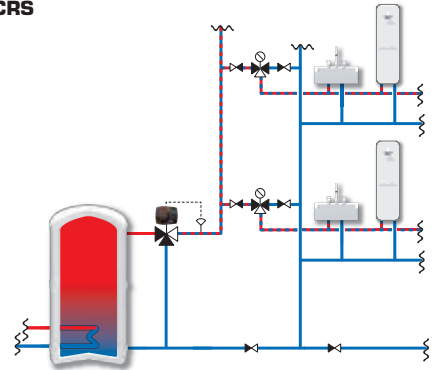

### SERIES CRS

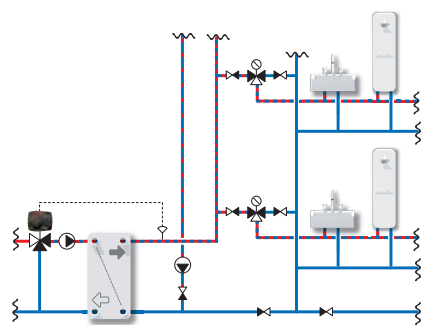

### SERIES CRS

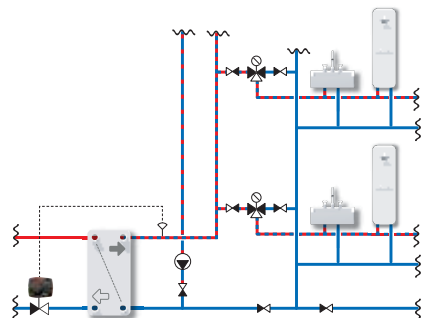

## ROTARY VALVES + CONTROLLERS INSTALLATION EXAMPLES

**SERIES 90C-1-90/90C-3-90**

1  

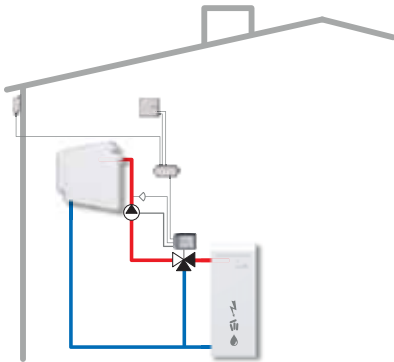
**SERIES 90C-1-90/90C-3-90**

2  

**SERIES 90C-3-90**

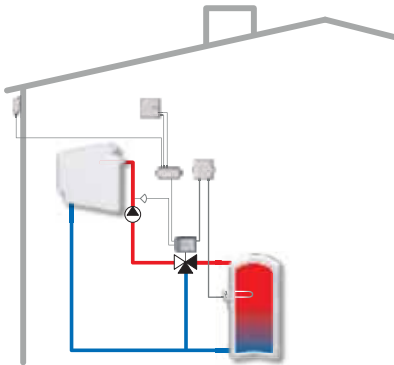
3  

**SERIES 90C-3-90**

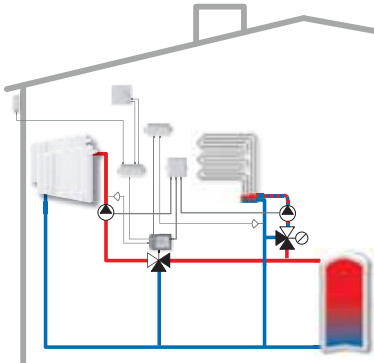
4  

**SERIES 90C-3-90**

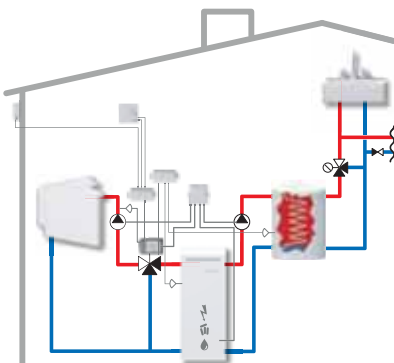
5  

**SERIES 90C-3-90**

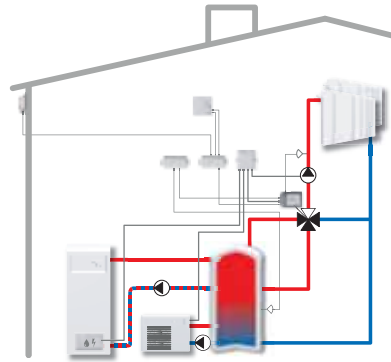
6  

**SERIES 90C-3-90**

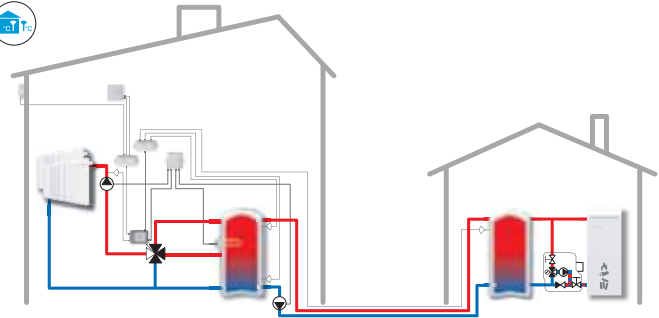
7  

**SERIES 90C-3-90** Addition of High temperature sensor CRS215 necessary.

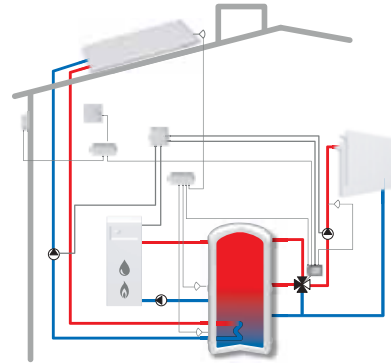
8  

# ROTARY ACTUATORS

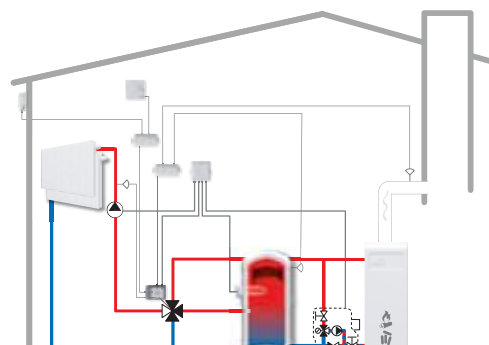
## RELIABLE. ROBUST. EASY TO HANDLE.

**Reliable actuators for** energy-efficient regulation in heating and cooling systems. And don't forget: the products are easy to use and install.



### Legend

**3-P** 3-point SPDT = Single Pole Double Throw

**2-P** 2-point SPST = Single Pole Single Throw

**Prop.** Proportional = 0..10 V, 2..10 V, 0..20mA, 4..20mA

 Spring return



Patented +  
Registered design



3-P

**ACTUATOR**  
Series ARA600, 3-point

- **Reliable and quiet operation**
- **Assortment for any need**
- **Perfect match between the actuator and ESBE valve**
- **Auxiliary switch available**

Series ARA600 with 3-point (open/close) signal is suitable for mixing operations together with valves such as VRG130 and VRB140. In these applications can any position of the actuator operating range be used to get the desired mix level. The compact actuator is designed for operating rotary valves DN 15-50 and has an operating range of 90°. The series can easily be manually operated by the pull-and-turn knob on the front of the cover. Auxiliary switch, available as premounted or optional kit, can be set in any position and is easily set by a unique solution.

**TECHNICAL DATA**

Ambient temperature: \_\_\_\_\_ max. +55°C  
 \_\_\_\_\_ min. -5°C  
 Power supply: \_\_\_\_\_ 24 ± 10% V AC, 50 Hz  
 \_\_\_\_\_ 230 ± 10% V AC, 50 Hz  
 Power consumption, 24 V: \_\_\_\_\_ 3 VA  
 230 V: \_\_\_\_\_ 5 VA  
 Control signal: \_\_\_\_\_ 3-point SPDT (Single Pole Double Throw)  
 Enclosure rating: \_\_\_\_\_ IP41  
 Protection class: \_\_\_\_\_ II  
 Torque: \_\_\_\_\_ See table  
 Rating auxiliary switch: \_\_\_\_\_ 6(3) A 250 V AC  
 Weight: \_\_\_\_\_ 0,4 kg

CE LVD 2014/35/EU – EMC 2014/30/EU – RoHS 2011/65/EU

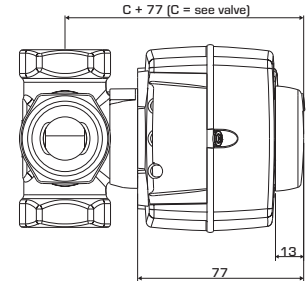
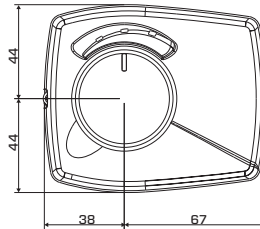

**ARA600 24 V AC**

Art. No.	Reference	Running time 90° [s]	Torque [Nm]	Note
12100100	ARA643	30	6	
12100200	ARA653	60	6	
12100700	ARA654			With premounted auxiliary switch
12100300	ARA663	120	6	
12100800	ARA664			With premounted auxiliary switch
12100400	ARA673	240	6	
12100500	ARA693	120/240/480/1200	6	

**ARA600 230 V AC**

Art. No.	Reference	Running time 90° [s]	Torque [Nm]	Note
12101100	ARA641	30	6	
12101600	ARA642			With premounted auxiliary switch
12101200	ARA651	60	6	
12101700	ARA652			With premounted auxiliary switch
12101300	ARA661	120	6	
12101800	ARA662			With premounted auxiliary switch
12101400	ARA671	240	6	
12101900	ARA672			With premounted auxiliary switch
12101500	ARA691	120/240/480/1200	6	

**FOR MORE VERSIONS .....WWW.ESBE.EU**



**ADDITIONAL GUIDANCE**

Accessories..... 74, 88–89  
 Guide & Dimensioning..... 59–60

For further detailed information ..... [www.esbe.eu](http://www.esbe.eu)

Patented +  
Registered design



2-P

## ACTUATOR

### Series ARA600, 2-point

- **Reliable and quiet operation**
- **Can be used for both 2-point and 3-point control signal**
- **Perfect match between the actuator and ESBE valve**
- **Auxiliary switch available**

Series ARA600 with 2-point (on/off) signal is suitable for diverting operations together with valves such as VRG230. In these applications will only the end-positions of the actuator operating range be used. The compact actuator is designed for operating rotary valves DN 15-50 and has an operating range of 90°. The series can easily be manually operated by the pull-and-turn knob on the front of the cover. Auxiliary switch, available as premounted or optional kit, can be set in any position and is easily set by a unique solution.

#### ARA600 24 V AC

Art. No.	Reference	Running time 90° [s]	Torque [Nm]	Note
12120100	ARA637	15	3	Recommended only for valves DN 15-32
12120200	ARA647	30	6	
12120600	ARA658	60	6	With premounted auxiliary switch

#### ARA600 230 V AC

Art. No.	Reference	Running time 90° [s]	Torque [Nm]	Note
12120700	ARA635	15	3	Recommended only for valves DN 15-32
12121000	ARA636			With premounted auxiliary switch, Recommended only for valves DN 15-32
12120800	ARA645	30	6	
12121100	ARA646			With premounted auxiliary switch
12120900	ARA655	60	6	
12121200	ARA656			With premounted auxiliary switch

#### TECHNICAL DATA

Ambient temperature: \_\_\_\_\_ max. +55°C  
 \_\_\_\_\_ min. -5°C  
 Power supply: \_\_\_\_\_ 24 ± 10% V AC, 50 Hz  
 \_\_\_\_\_ 230 ± 10% V AC, 50 Hz  
 Power consumption, 24 V: \_\_\_\_\_ 3 VA  
 230 V: \_\_\_\_\_ 5 VA  
 Control signal: \_\_\_\_\_ 2-point SPST (Single Pole Single Throw)  
 Enclosure rating: \_\_\_\_\_ IP41  
 Protection class: \_\_\_\_\_ II  
 Torque: \_\_\_\_\_ See table  
 Rating auxiliary switch: \_\_\_\_\_ 6(3)A 250 V AC  
 Weight: \_\_\_\_\_ 0,4 kg

CE LVD 2014/35/EU - EMC 2014/30/EU - RoHS 2011/65/EU

Patented +  
Registered design



Prop.

## ACTUATOR

### Series ARA600, Proportional

- **Superb regulation with reliable and quiet operation**
- **Different kinds of control signals possible**
- **Perfect match between the actuator and ESBE valve**
- **Auxiliary switch available**

Series ARA600 with proportional (voltage/current) signal is suitable for mixing operations together with valves such as VRG130 and VRB140. In these applications can any position of the actuator operating range be used to get the desired mix level. The actuator is controlled by a voltage or current control signal and offer a more precise operation of the actuator and valve.

#### ARA600 24 V AC/DC

Art. No.	Reference	Running time 90° [s]	Torque [Nm]	Note
12520100	ARA639	15/30/60/120	6	
12520200	ARA659	45/120		

#### TECHNICAL DATA

Ambient temperature: \_\_\_\_\_ max. +55°C  
 \_\_\_\_\_ min. -5°C  
 Power supply: \_\_\_\_\_ 24 ± 10% V AC/DC, 50/60 Hz  
 Enclosure rating: \_\_\_\_\_ IP41  
 Protection class: \_\_\_\_\_ II  
 Torque: \_\_\_\_\_ See table  
 Power consumption - Operation, AC: \_\_\_\_\_ 5 W  
 DC: \_\_\_\_\_ 2,5 W  
 Power consumption - Dimensioning, AC: \_\_\_\_\_ ARA639, 11 VA  
 \_\_\_\_\_ ARA659, 8 VA  
 DC: \_\_\_\_\_ ARA639, 6 VA  
 \_\_\_\_\_ ARA659, 4 VA  
 Control signal: \_\_\_\_\_ Proportional (0..10 V, 2..10 V, 0..20mA, 4..20mA)  
 Rating auxiliary switch: \_\_\_\_\_ 6(3) A 250 V AC  
 Weight: \_\_\_\_\_ 0,4 kg

CE LVD 2014/35/EU - EMC 2014/30/EU - RoHS 2011/65/EU





3-P

**ACTUATOR**  
 Series 90, 3-point

- Adjustable operating range
- Assortment for any need
- Auxiliary switch available

Series 90 with 3 point (open / close) signal is suitable for mixing operations together with valves such as 3F, 4F, 5MG and VBF100. In these applications can any position of the actuator operating range be used to get the desired mix level. The actuator is designed for operating rotary valves DN 15-150 and has adjustable cam discs to obtain an operating range of 30°-180° or even 270°, depending of version. The series can easily be manually operated by a disconnection button and lever.

**TECHNICAL DATA**

Ambient temperature: \_\_\_\_\_ max. +55°C  
 \_\_\_\_\_ min. -15°C  
 Power supply: \_\_\_\_\_ 24 ± 10% V AC, 50 Hz  
 \_\_\_\_\_ 230 ± 10% V AC, 50 Hz  
 Power consumption: \_\_\_\_\_ Actuator 24 V AC, 2 VA  
 \_\_\_\_\_ Actuator 230 V AC, 5 VA  
 Control signal \_\_\_\_\_ 3-point SPDT (Single Pole Double Throw)  
 Enclosure rating: \_\_\_\_\_ IP 54  
 Protection class: \_\_\_\_\_ II  
 Torque: \_\_\_\_\_ See table  
 Rating auxiliary switch: \_\_\_\_\_ 6(3) A 250 V AC  
 Weight: \_\_\_\_\_ 0,8 kg

CE LVD 2014/35/EU - EMC 2014/30/EU - RoHS 2011/65/EU

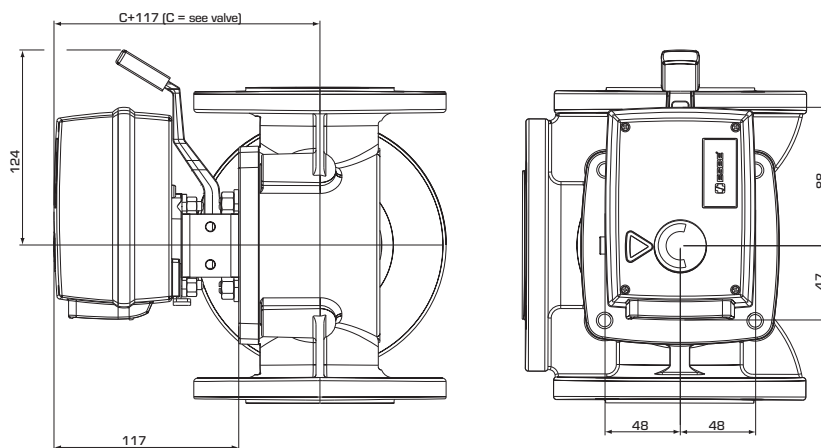

**90 24 V AC**

Art. No.	Reference	Running time 90° [s]	Torque [Nm]	Note
12050200	91	15	5	
12050600	92	60	15	With premounted auxiliary switch
12051100	92M			
12050700	92-2	120	15	
12051300	93	240	15	

**90 230 V AC**

Art. No.	Reference	Running time 90° [s]	Torque [Nm]	Note
12051700	94	15	5	With premounted auxiliary switch
12051800	94M			
12051900	95	60	15	With premounted auxiliary switch
12052200	95M			
12052000	95-2	120	15	With premounted auxiliary switch
12052100	95-2M			
12053300	95-270M	50	5	With premounted auxiliary switch. Operating range 270°, Running time 270° - 150s (preset)
12052300	96	240	15	With premounted auxiliary switch
12052400	96M			

FOR MORE VERSIONS ..... [WWW.ESBE.EU](http://WWW.ESBE.EU)



**ADDITIONAL GUIDANCE**

Accessories..... 74, 88–89  
 Guide & Dimensioning..... 59–60  
 Installation examples..... 63  
 For further detailed information ..... [www.esbe.eu](http://www.esbe.eu)



2-P

## ACTUATOR

### Series 90, 2-point

- Adjustable operating range
- With built-in relay

Series 90 with 2-point (on/off) signal is suitable for diverting operations together with change over / diverting valves. In these applications will only the end-positions of the actuator operating range be used. The actuator has built-in relay and should be selected when the actuator is to be controlled by an on/off-thermostat.

#### TECHNICAL DATA

Ambient temperature: \_\_\_\_\_ max. +55°C  
 \_\_\_\_\_ min. -15°C  
 Power supply: \_\_\_\_\_ 230 ± 10% V AC, 50 Hz  
 Power consumption: \_\_\_\_\_ 5 VA  
 Control signal: \_\_\_\_\_ 2-point SPST (Single Pole Single Throw)  
 Enclosure rating: \_\_\_\_\_ IP 54  
 Protection class: \_\_\_\_\_ II  
 Torque: \_\_\_\_\_ See table  
 Rating auxiliary switch: \_\_\_\_\_ 6(3) A 250 V AC  
 Weight: \_\_\_\_\_ 0,8 kg

CE LVD 2014/35/EU - EMC 2014/30/EU - RoHS 2011/65/EU

### 90 230 V AC

Art. No.	Reference	Running time 90° [s]	Torque [Nm]	Note
12052500	97	15	5	With built-in relay
12052600	98	60	15	



Prop.

## ACTUATOR

### Series 90, Proportional

- Adjustable operating range
- Assortment for any need
- Different kinds of control signals possible

Series 90 with proportional (voltage/current) signal is suitable for mixing operations together with valves such as 3F, 4F, 5MG and VBF100. In these applications can any position of the actuator operating range be used to get the desired mix level. The actuator is controlled by a voltage or current control signal and offer a more precise operation of the actuator and valve. The actuator is designed for operating rotary valves DN 15-150 and has adjustable cam discs to obtain an operating range of 30°-180° or even 355°, dependning of version. The series can easily be manually operated by a disconnection button and lever.

#### TECHNICAL DATA

Ambient temperature: \_\_\_\_\_ max. +55°C  
 \_\_\_\_\_ min. -15°C  
 Power supply: \_\_\_\_\_ 24 ± 10% V AC/DC, 50/60 Hz  
 Power consumption: \_\_\_\_\_ 5 VA  
 Control signal: \_\_\_\_\_ Proportional (0..10 V, 2..10 V, 0..20mA, 4..20mA)  
 Enclosure rating: \_\_\_\_\_ IP 54  
 Protection class: \_\_\_\_\_ II  
 Torque: \_\_\_\_\_ See table  
 Rating auxiliary switch: \_\_\_\_\_ 6(3) A 250 V AC  
 Weight: \_\_\_\_\_ 0,8 kg

CE LVD 2014/35/EU - EMC 2014/30/EU - RoHS 2011/65/EU

### 90 24 V AC/DC

Art. No.	Reference	Running time [s]	Torque [Nm]	Note
12550100	92P	60/90/ 120 <sup>1)</sup>	15	Operating range 30-90°
12550200	92P2	120/180/240 <sup>2)</sup>		Operating range 30-180°
12550400	92P4	130/260/390 <sup>3)</sup>		Operating range 180-355°



#### ADDITIONAL GUIDANCE

Accessories..... 74, 88-89      Installation examples..... 63  
 Guide & Dimensioning..... 59-60      For further detailed information ..... www.esbe.eu

Note 1) At 90° operating range. 2) At 180° operating range. 3) At 355° operating range.



**ACTUATOR**  
 Series ARC300

- **30 Nm strong actuator**
- **Perfect match between the actuator and ESBE valves 3F/4F, VBF100**
- **Comes with adapter for clamp couplig for spindle assembly**
- **Different control signals available**

The ESBE series ARC300 is an actuator suitable for both rotary mixing valves as well as damper applications. Thanks to the high torque ARC300 is suitable to work with the largest ESBE valve DN100-150 and with dampers sizes up to 6m<sup>2</sup>. The actuator comes with 2 sets of adapters, one set for assembly on ESBE valves 3F/4F and one set with clamp coupling for damper spindle assembly.

**TECHNICAL DATA**

Ambient temperature: \_\_\_\_\_ max. +50°C  
 \_\_\_\_\_ min. -30°C  
 Ambient humidity: \_\_\_\_\_ 5...95% r.H. non-condensating  
 Power supply: \_\_\_\_\_ 24V AC (50/60 Hz), 24V DC  
 \_\_\_\_\_ 230V AC (50/60 Hz), 230V DC  
 Nominal voltage range: \_\_\_\_\_ 19...29V AC/DC,  
 \_\_\_\_\_ 85...265V AC/DC  
 Power consumption, running, 24V: \_\_\_\_\_ 4,5 W  
 \_\_\_\_\_ 230V: \_\_\_\_\_ 4,0 W  
 Power consumption, standby, 24V/230V: \_\_\_\_\_ 1,5 W  
 Wiring sizing, 24V: \_\_\_\_\_ 6,0 VA  
 \_\_\_\_\_ 230V: \_\_\_\_\_ 7,5 VA  
 Enclosure rating: \_\_\_\_\_ IP54  
 Protection class, 24V: \_\_\_\_\_ III  
 \_\_\_\_\_ 230V: \_\_\_\_\_ II  
 Torque: \_\_\_\_\_ 30Nm  
 Running time: \_\_\_\_\_ 150s/90°  
 Rating auxiliary switch (ARC368): \_\_\_\_\_ 5(2,5) A, 250V AC  
 Cable length: \_\_\_\_\_ 1m  
 Weight: \_\_\_\_\_ 1,7 kg

CE LVD 2014/35/EU - EMC 2014/30/EU - RoHS 2011/65/EU

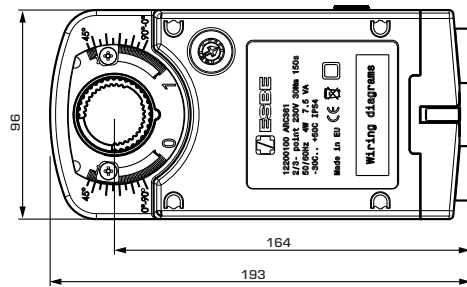

Actuator

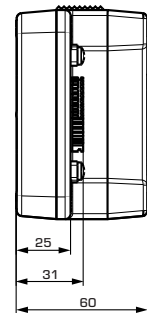

Damper assembly kit

**ARC300 24V AC/DC 3-point/2-point**

Art. No.	Reference	Running time 90° [s]	Control signal	Torque [Nm]	Note
12201100	ARC363	150	2-point SPST/ 3-point SPDT	30	

**ARC300 230V AC/DC 3-point/2-point**

Art. No.	Reference	Running time 90° [s]	Control signal	Torque [Nm]	Note
12200100	ARC361	150	2-point SPST/ 3-point SPDT	30	

**ARC300 24V AC/DC proportional**

Art. No.	Reference	Running time 90° [s]	Control signal	Torque [Nm]	Note
12220100	ARC369	150	Proportional (0.10 V, 2.10 V, 0.20mA, 4.20mA)	30	With 2 independent premounted auxiliary switches
12220200	ARC368				



**ADDITIONAL GUIDANCE**

Accessories.....	88	Installation examples.....	63
Guide & Dimensioning.....	60	For further detailed information .....	<a href="http://www.esbe.eu">www.esbe.eu</a>



## ACTUATOR

### Series ARD100, ARD200

- Spring return actuator for failsafe operation
- Perfect match between the actuator and ESBE valves 3F/4F, VBF100
- Comes with adapter for clamp coupling for spindle assembly
- Different control signals available

The ESBE series ARD100 and ARD200 are a range of actuators suitable for both rotary mixing valves as well as damper applications.

The ARD100 is suitable to work with ESBE valves up to DN80, and with damper sizes up to 2m<sup>2</sup>. Thanks to the high torque ARD200 is suitable to work with the largest ESBE valve DN100-150, and with dampers sizes up to 4m<sup>2</sup>. The actuator comes with 2 sets of adapters; one set for assembly on ESBE valves 3F/4F, and one set with clamp coupling for damper spindle assembly.

#### TECHNICAL DATA

Ambient temperature: \_\_\_\_\_ max. +50°C  
 \_\_\_\_\_ min. -30°C  
 Ambient humidity: \_\_\_\_\_ 5...95% r.H. non-condensating  
 Power supply: \_\_\_\_\_ 24V AC (50/60 Hz), 24V DC  
 \_\_\_\_\_ 230V AC (50/60 Hz), 230V DC  
 Nominal voltage range: \_\_\_\_\_ 19...29V AC/DC,  
 \_\_\_\_\_ 85...265V AC/DC  
 Enclosure rating: \_\_\_\_\_ IP54  
 Protection class, 24V: \_\_\_\_\_ III  
 230V: \_\_\_\_\_ II  
 Cable length: \_\_\_\_\_ 1m

CE LVD 2014/35/EU - EMC 2014/30/EU - RoHS 2011/65/EU

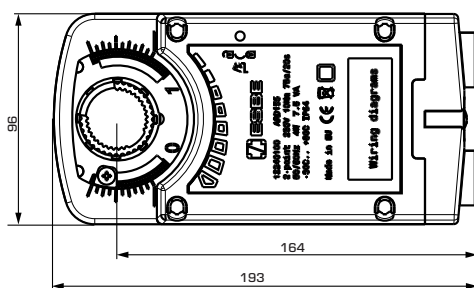

Actuator

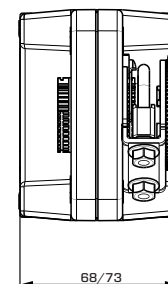
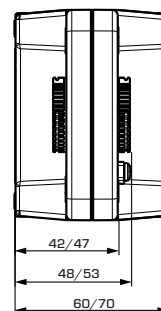

Damper assembly kit

#### ARDx00 24V AC/DC 2-point, spring return

Art. No.	Reference	Power consumption [W]		Wiring sizing [VA]	Running time 90° [s]		Torque [Nm]	Weight [kg]	Note
		running	standby		Opening	closing			
12241100	ARD157	5	2	8	75	20	10	1,8	
12241200	ARD257	10,5	2,5	14			20	2,4	

#### ARDx00 230V AC/DC 2-point, spring return

Art. No.	Reference	Power consumption [W]		Wiring sizing [VA]	Running time 90° [s]		Torque [Nm]	Weight [kg]	Note
		running	standby		Opening	closing			
12240100	ARD155	5,5	1,5	11,5	75	20	10	1,8	
12240200	ARD255	10,5	2	22,5			20	2,4	

#### ARDx00 24V AC/DC proportional, spring return

Art. No.	Reference	Power consumption [W]		Wiring sizing [VA]	Running time 90° [s]		Torque [Nm]	Weight [kg]	Note
		running	standby		Opening	closing			
12260100	ARD169	5	2	8	150	20	10	1,8	
12260200	ARD269	10,5	2,5	14			20	2,4	



#### ADDITIONAL GUIDANCE

Accessories.....	88	Installation examples.....	63
Guide & Dimensioning.....	60	For further detailed information.....	www.esbe.eu



## VALVE + ACTUATOR

### Series VRG131 + ARA661

Valve series VRG and actuator series ARA delivered as a set in an all-in-one package. For more information about the products, please see separate product pages.

#### ADDITIONAL GUIDANCE

Valve info .....41    Actuator info .....68

#### VRG131 + ARA661

Art. No.	Pressure class	Mixing valve VRG131			Control signal	Actuator ARA661			Note
		DN	Kvs	Connection		Power supply	Running time 90° [s]	Torque [Nm]	
13020600	PN 10	15	2,5	Rp 1/2"	3-point SPDT	230 V AC	120	6	
13020700		20	4	Rp 3/4"					
13022300		20	6,3						
13020800		25	6,3	Rp 1"					
13022400		25	10						

## ESBE ACCESSORIES

### AUXILIARY SWITCH

#### Series ARA600



Art. No.	Reference	Designation
16200700	ARA801	Auxiliary switch kit ARA600

### AUXILIARY SWITCH

#### Series 90



Art. No.	Reference	Designation
98100690	-	Separate Auxiliary switch, 90







# CONTROLLERS

## ENERGY SAVINGS. NICE LOOKING. QUICK UP-AND-RUNNING.

**ESBEs assortments of controllers** have all in common that they make it easy to deliver comfort, safety and energy savings.



### Legend

-  Combined weather compensating and indoor sensor based controller
-  Indoor sensor based controller
-  Weather compensation controller
-  Constant flow temperature controller made especially for PWx (Potable water applications)
-  Constant temperature controller
-  Connected to ESBE cloud services Comfort Control







**CONTROLLER**  
Series CRA110

- **Easy and quick to install**
- **Controller with integrated actuator**
- **Superb regulation**
- **Perfect match between the controller and ESBE valve**

Series CRA110 is a constant flow temperature controller for applications where a constant water temperature is required. Temperature settings is done by an easy-to-use joystick and display interface. The compact controller is designed for operating rotary valves DN 15-50 and has an operating range of 90°. The series can easily be manually operated by the pull-and-turn knob on the front of the cover.

**TECHNICAL DATA**

Ambient temperature: \_\_\_\_\_ max. +55°C  
 \_\_\_\_\_ min. -5°C  
 Sensors: \_\_\_\_\_ Temperature sensor type NTC  
 Temperature range, flow pipe sensor: \_\_\_\_\_ +5 to +95°C  
 Enclosure rating: \_\_\_\_\_ IP41  
 Protection class: \_\_\_\_\_ II  
 Power supply: \_\_\_\_\_ 24 ± 10% V AC, 50/60 Hz  
 \_\_\_\_\_ 230 ± 10% V AC, 50 Hz  
 Power consumption - 24 V AC: \_\_\_\_\_ 3 VA  
 - 230 V AC: \_\_\_\_\_ 10 VA  
 Torque: \_\_\_\_\_ 6 Nm  
 Running time at max. speed: \_\_\_\_\_ 30s  
 Weight: \_\_\_\_\_ 0,4 kg

CE LVD 2014/35/EU - EMC 2014/30/EU - RoHS 2011/65/EU

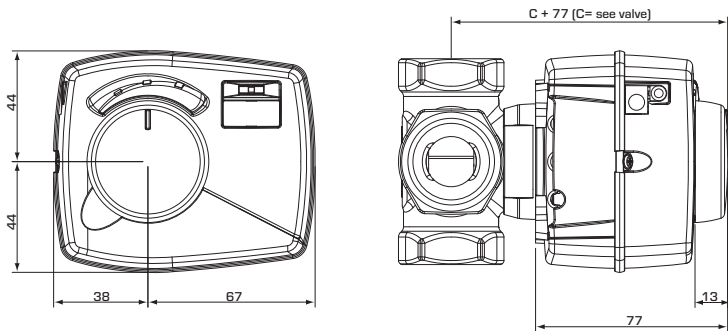

Installation dimensions for Controller Series CRA110 with ESBE VRG100, VRG200, VRG300, VRH100 and VRB100 mixing valves

Art. No.	Reference	Torque [Nm]	Voltage [VAC]	Note
12720100	CRA111	6	230	Transformer with UK plug
12720500	CRA115			
12720200	CRA112		24	



**ADDITIONAL GUIDANCE**

Accessories..... 88–90  
 Guide & Dimensioning..... 59  
 Installation examples..... 63  
 For further detailed information ..... [www.esbe.eu](http://www.esbe.eu)



## CONTROLLER Series CRA120

- Adjustable operating range
- For valves up to DN150
- Superb regulation

Series CRA120 is a constant flow temperature controller suited for larger systems and valves such as 3F. The product is perfect for applications where a constant water temperature is required. Temperature settings is done by an easy-to-use push buttons and display interface. The controller is designed for operating rotary valves DN 15-150 and has an operating range of 30-180°. The series can easily be manually operated by a disconnection button and lever.

### TECHNICAL DATA

Ambient temperature: \_\_\_\_\_ max. +55°C  
 \_\_\_\_\_ min. -5°C  
 Sensors: \_\_\_\_\_ Temperature sensor type NTC  
 Temperature range - Flow pipe sensor: \_\_\_\_\_ +5 to +95°C  
 Enclosure rating - Actuator unit: \_\_\_\_\_ IP54  
 - Control box: \_\_\_\_\_ IP54  
 Protection class: \_\_\_\_\_ II  
 Power supply: \_\_\_\_\_ 24 ± 10% V AC, 50/60 Hz  
 \_\_\_\_\_ 230 ± 10% V AC, 50 Hz  
 Power consumption - 24 V AC: \_\_\_\_\_ 3 VA  
 - 230 V AC: \_\_\_\_\_ 10 VA  
 Torque: \_\_\_\_\_ 15 Nm  
 Running time at max. speed: \_\_\_\_\_ 120s  
 Weight: \_\_\_\_\_ 0,9 kg

CE LVD 2014/35/EU - EMC 2014/30/EU - RoHS 2011/65/EU

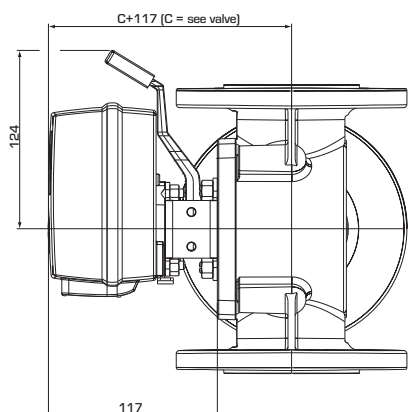

Installation dimensions for Actuator Series CRA120 with ESBE series MG, G, F, T/TM, H/HG and BIV mixing valves

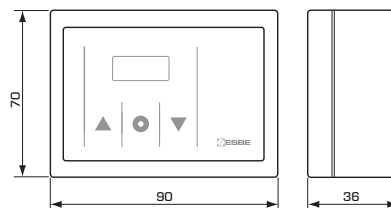
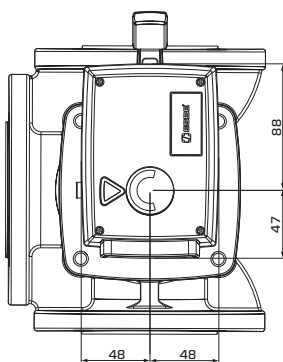

Installation dimensions for Control box

Art. No.	Reference	Torque [Nm]	Voltage [VAC]	Note
12742100	CRA121	15	230	Transformer with UK plug
12742500	CRA125			
12742200	CRA122		24	



### ADDITIONAL GUIDANCE

Accessories..... 88-90      Installation examples..... 63  
 Guide & Dimensioning..... 59-60      For further detailed information..... [www.esbe.eu](http://www.esbe.eu)



**CONTROLLER**  
Series CRA140

- **Constant temperature controller**
- **Return temperature protection**
- **Controller with integrated actuator**
- **Easy and quick to install**

The ESBE series CRA140 is a combined constant flow temperature and return temperature controller with integrated actuator made especially for applications where 2 flow temperatures needs to be controlled. The controller is designed to provide a constant flow temperature and at the same time keep a second flow temperature within a changeable temperature window. Temperature setting is done by an easy-to-use joystick and display interface. Adjustable temperature setting within the range of 5 - 95°C. The compact controller is designed for operating rotary valves DN 15-50 and has an operating range of 90°.

**TECHNICAL DATA**

Ambient temperature: \_\_\_\_\_ max. +55°C  
 \_\_\_\_\_ min. -5°C  
 Sensors: \_\_\_\_\_ Temperature sensor type NTC  
 Temperature range Flow pipe sensor S1 and S2: \_\_\_\_\_ +5 to +95°C  
 Enclosure rating: \_\_\_\_\_ IP41  
 Protection class: \_\_\_\_\_ II  
 Power supply: \_\_\_\_\_ 230 ± 10% V AC, 50 Hz  
 Power consumption - 230 V AC: \_\_\_\_\_ 10 VA  
 Torque: \_\_\_\_\_ 6 Nm  
 Running time at max. speed: \_\_\_\_\_ 30s  
 Weight: \_\_\_\_\_ 0,7 kg

CE LVD 2014/35/EU - EMC 2014/30/EU - RoHS 2011/65/EU

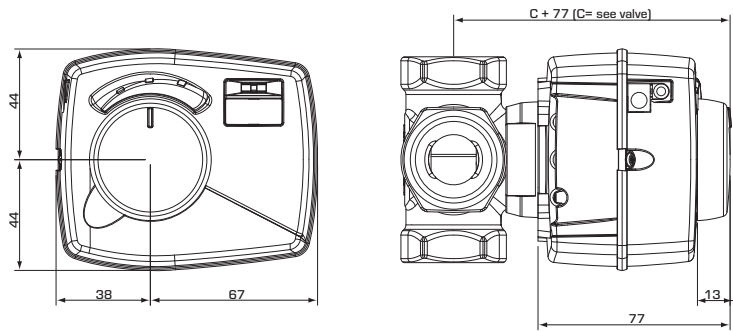

Installation dimensions for Controller Series CRA140 with ESBE VRG100, VRG200, VRG300, VRH100 and VRB100 mixing valves

Art. No.	Reference	Torque [Nm]	Voltage [VAC]	Note
12724100	CRA141	6	230	



**ADDITIONAL GUIDANCE**

- Accessories..... 88–90
- Installation examples..... 64
- Guide & Dimensioning..... 59
- For further detailed information..... [www.esbe.eu](http://www.esbe.eu)



## CONTROLLER Series CRA150

- **Constant temperature controller**
- **Combine heating and cooling in the same circuit, with the same mixing valve and controller with integrated actuator**
- **Easy and quick to install**

ESBE series CRA150 is a combined actuator and constant flow temperature controller made especially for applications with heating and cooling possibility in the same circuit. The controller is able to control 2 different modes. The primary mode is for example heating; in this mode the controller will mix the hot fluid with the return fluid according to the set temperature. The secondary mode, for example cooling, is activated by an external signal and when active the controller will change working direction and mix the cold fluid with the return fluid according to the alternative set temperature. Temperature setting is done by an easy-to-use joystick and display interface and the temperature setting is adjustable within the range of 5 - 95°C.

### TECHNICAL DATA

Ambient temperature: \_\_\_\_\_ max. +55°C  
 \_\_\_\_\_ min. -5°C  
 Sensors: \_\_\_\_\_ Temperature sensor type NTC  
 Temperature range Flow pipe sensor \_\_\_\_\_ +5 to +95°C  
 Enclosure rating: \_\_\_\_\_ IP41  
 Protection class: \_\_\_\_\_ II  
 Power supply: \_\_\_\_\_ 230 ± 10% V AC, 50 Hz  
 Power consumption - 230 V AC: \_\_\_\_\_ 10 VA  
 Torque: \_\_\_\_\_ 6 Nm  
 Running time at max. speed: \_\_\_\_\_ 30s  
 Weight: \_\_\_\_\_ 0,7 kg

CE LVD 2014/35/EU – EMC 2014/30/EU – RoHS 2011/65/EU

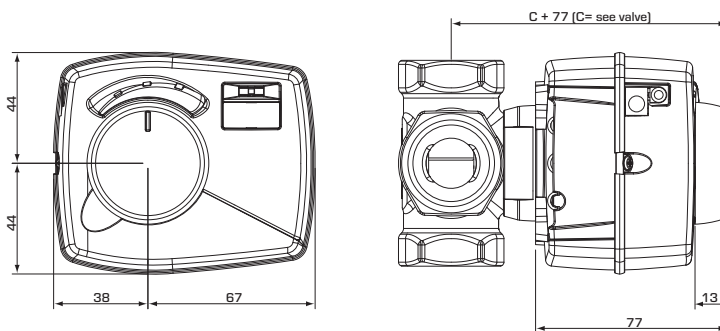

Installation dimensions for Controller Series CRA150 with ESBE VRG100, VRG200, VRG300 and VRH100 mixing valves

Art. No.	Reference	Torque [Nm]	Voltage [VAC]	Note
12725100	CRA151	6	230	



### ADDITIONAL GUIDANCE

Accessories.....	88–90	Installation examples.....	64
Guide & Dimensioning.....	59	For further detailed information.....	<a href="http://www.esbe.eu">www.esbe.eu</a>



**CONTROLLER**  
Series CRB100

- **Wireless comfort**
- **Easy and quick to install**
- **All adjustment from the room unit**

Series CRB100 is an indoor based controller with integrated actuator for use on mixing valves like VRG130 and VRB140. The controller is designed to provide a high level of comfort and at the same time provide energy savings for the house owner. The regulation is based on indoor sensor feedback and is changed by altering the target temperature in the room display unit. The actuator unit can be connected to the room display unit either by wireless radio connection (CRB120) for easy installation or by cable (CRB110). With the inbuilt timer, with day and week program, there are possibilities to have day and night settings with an alternative temperature for even further energy savings.

**TECHNICAL DATA**

Ambient temperature: \_\_\_\_\_ max. +55°C  
 \_\_\_\_\_ min. -5°C  
 Sensors: \_\_\_\_\_ Temperature sensor type NTC  
 Temperature range - Flow pipe sensor: \_\_\_\_\_ +5 to +95°C  
 - Room sensor: \_\_\_\_\_ +5 to +30°C  
 ErP Temperature controls class: \_\_\_\_\_ IV  
 Energy efficiency contribution: \_\_\_\_\_ 2%  
 Enclosure rating - Actuator unit: \_\_\_\_\_ IP41  
 - Room display unit: \_\_\_\_\_ IP20  
 Protection class: \_\_\_\_\_ II  
 Power supply - Actuator unit: \_\_\_\_\_ 230 ± 10% VAC, 50 Hz  
 - Room display unit - wireless: \_\_\_\_\_ 2x 1,5 V LR6/AA  
 Power consumption - 230 V AC: \_\_\_\_\_ 10 VA  
 Battery endurance, wireless room display unit: \_\_\_\_\_ 1 year  
 Rating auxiliary switch: \_\_\_\_\_ 6(3) A 250 V AC  
 Torque: \_\_\_\_\_ 6 Nm  
 Running time at max. speed: \_\_\_\_\_ 30s  
 Room display unit cable: \_\_\_\_\_ 20m  
 Radio frequency: \_\_\_\_\_ 868MHz  
 \_\_\_\_\_ ITU region 1 approved acc. to EN 300220-2  
 Weight: \_\_\_\_\_ 0,9 kg

CE LVD 2014/35/EU – EMC 2014/30/EU – RoHS 2011/65/EU

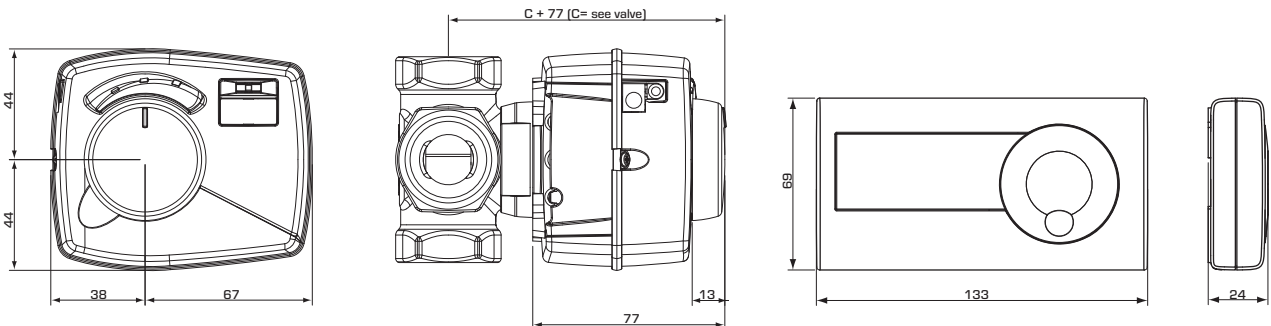

Installation dimensions for Controller Series CRB100 with ESBE VRG100, VRG200, VRG300, VRH100 and VRB100 mixing valves

Installation dimensions for Room display units

Art. No.	Reference	Torque [Nm]	Voltage [VAC]	Room display unit	Note
12660100	CRB111	6	230	Cable	Without internal timer
12661400	CRB114				With pump control wire box
12662200	CRB122			Wireless	
12662500	CRB125				Transformer with UK plug



**ADDITIONAL GUIDANCE**

Accessories..... 88–90  
 Guide & Dimensioning..... 59

Installation examples..... 65  
 For further detailed information..... [www.esbe.eu](http://www.esbe.eu)



## CONTROLLER Series CRC110

- **Set the perfect heat curve according to your need**
- **Superb regulation**
- **Easy and quick to install**
- **Controller with integrated actuator**

Series CRC110 is an outdoor sensor based controller with integrated actuator for use on mixing valves like VRG130 and VRB140. The controller is designed to provide a high level of comfort thanks to the possibility to set a perfect characteristic heating curve and at the same time provide energy savings for the house owner. The regulation is based on outdoor sensor feedback and an adjustable characteristic heating curve. An offset / parallel adjustment of the characteristic heating curve may be activated by an external signal for example night settings. For applications with well insulated building and quick heating systems such as radiator circuit can a temperature filter be activated to delay an outdoor temperature change to avoid an imbalance between estimated and actual heating demand.

### TECHNICAL DATA

Ambient temperature: \_\_\_\_\_ max. +55°C  
 \_\_\_\_\_ min. -5°C  
 Sensors: \_\_\_\_\_ Temperature sensor type NTC  
 Temperature range - Flow pipe sensor: \_\_\_\_\_ +5 to +95°C  
 - Outdoor sensor: \_\_\_\_\_ -50 to +70°C  
 ErP Temperature controls class: \_\_\_\_\_ III  
 Energy efficiency contribution: \_\_\_\_\_ 1,5%  
 Enclosure rating - Actuator unit: \_\_\_\_\_ IP41  
 Protection class: \_\_\_\_\_ II  
 Power supply - Actuator unit: \_\_\_\_\_ 230 ± 10% VAC, 50 Hz  
 Power consumption - 230 V AC: \_\_\_\_\_ 10 VA  
 Torque: \_\_\_\_\_ 6 Nm  
 Running time at max. speed: \_\_\_\_\_ 30s  
 Weight: \_\_\_\_\_ 0,9 kg

CE LVD 2014/35/EU - EMC 2014/30/EU - RoHS 2011/65/EU

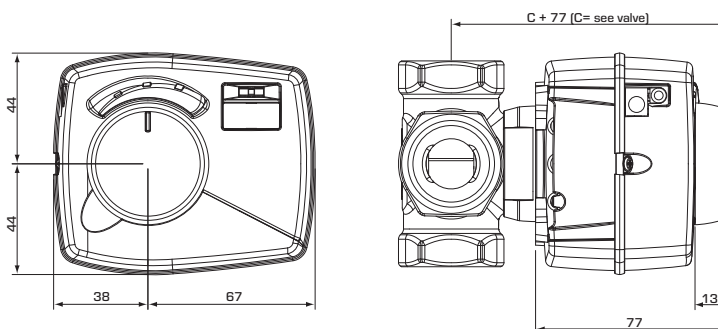

Installation dimensions for Controller Series CRC110 with ESBE VRG100, VRG200, VRG300, VRH100 and VRB100 mixing valves

Art. No.	Reference	Torque [Nm]	Voltage [VAC]	Note
12820100	CRC111	6	230	
12820300	CRC113			With pump control wire box
12820500	CRC115			Transformer with UK plug



### ADDITIONAL GUIDANCE

Accessories..... 88–90  
 Guide & Dimensioning..... 59  
 Installation examples..... 64  
 For further detailed information..... [www.esbe.eu](http://www.esbe.eu)





**CONTROLLER**  
Series CRC120

- **Weather compensating controller**
- **Set the perfect heat curve according to your need**
- **For valves up to DN150**
- **Adjustable operating range (30-180°)**

Series CRC120 is an outdoor sensor based controller suited for larger systems and valves such as 3F. The controller is designed to provide a high level of comfort thanks to the possibility to set a perfect characteristic heating curve and at the same time provide energy savings for the house owner. The regulation is based on outdoor sensor feedback and an adjustable characteristic heating curve. An offset / parallel adjustment of the characteristic heating curve may be activated by an external signal for example night settings. For applications with well insulated building and quick heating systems such as radiator circuit can a temperature filter be activated to delay an outdoor temperature change to avoid an imbalance between estimated and actual heating demand.

**TECHNICAL DATA**

Ambient temperature: \_\_\_\_\_ max. +55°C  
 \_\_\_\_\_ min. -5°C  
 Sensors: \_\_\_\_\_ Temperature sensor type NTC  
 Temperature range - Flow pipe sensor: \_\_\_\_\_ +5 to +95°C  
 - Outdoor sensor: \_\_\_\_\_ -50 to +70°C  
 ErP Temperature controls class: \_\_\_\_\_ III  
 Energy efficiency contribution: \_\_\_\_\_ 1,5%  
 Enclosure rating - Actuator unit: \_\_\_\_\_ IP54  
 - Control box: \_\_\_\_\_ IP54  
 Protection class: \_\_\_\_\_ II  
 Power supply: \_\_\_\_\_ 230 ± 10% V AC, 50 Hz  
 Power consumption - 230 V AC: \_\_\_\_\_ 10 VA  
 Torque: \_\_\_\_\_ 15 Nm  
 Running time at max. speed: \_\_\_\_\_ 120s  
 Weight: \_\_\_\_\_ 1,8 kg

CE LVD 2014/35/EU - EMC 2014/30/EU - RoHS 2011/65/EU

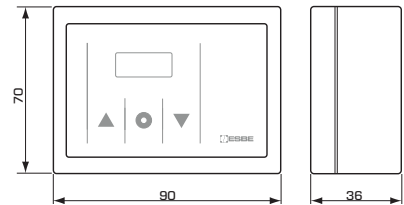
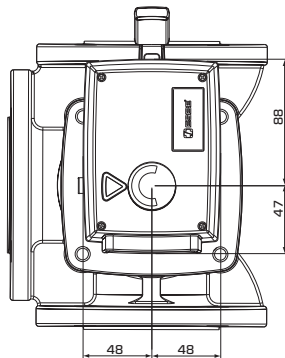
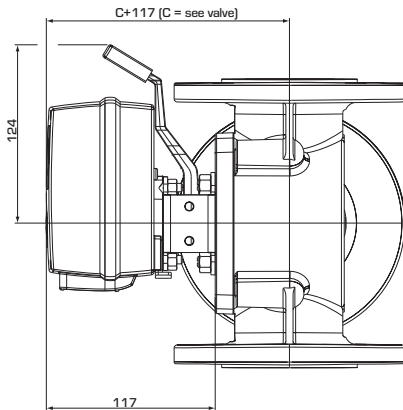

Installation dimensions for Actuator Series CRC120 with ESBE series MG, G, F, T/TM, H/HG and BIV mixing valves

Installation dimensions for Control box

Art. No.	Reference	Torque [Nm]	Voltage [VAC]	Note
12842100	CRC121	15	230	Transformer with UK plug
12842500	CRC125			



**ADDITIONAL GUIDANCE**

Accessories..... 88–90      Installation examples..... 64  
 Guide & Dimensioning..... 59–60      For further detailed information..... [www.esbe.eu](http://www.esbe.eu)



## CONTROLLER Series CRC140

- **Weather compensating controller**
- **Return temperature protection**
- **Set the perfect heat curve according to your need**
- **Controller with integrated actuator**

The ESBE series CRC140 is a combined weather compensating and return temperature controller with integrated actuator made especially for applications with a heat circuit, 4-way valve and boiler without storage tank. The controller is designed to provide a high level of comfort thanks to the possibility to set a perfect characteristic heating curve and at the same time protect the boiler from too low or too high return temperature. The compact controller is designed for operating rotary valves DN 15-50 and has an operating range of 90°.

### TECHNICAL DATA

Ambient temperature: \_\_\_\_\_ max. +55°C  
 \_\_\_\_\_ min. -5°C  
 Sensors: \_\_\_\_\_ Temperature sensor type NTC  
 Temperature range - Flow pipe sensor S1 and S2: \_\_\_\_\_ +5 to +95°C  
 - Outdoor sensor: \_\_\_\_\_ -50 to +70°C  
 ErP Temperature controls class: \_\_\_\_\_ III  
 Energy efficiency contribution: \_\_\_\_\_ 1,5%  
 Enclosure rating: \_\_\_\_\_ IP41  
 Protection class: \_\_\_\_\_ II  
 Power supply: \_\_\_\_\_ 230 ± 10% V AC, 50 Hz  
 Power consumption - 230 V AC: \_\_\_\_\_ 10 VA  
 Torque: \_\_\_\_\_ 6 Nm  
 Running time at max. speed: \_\_\_\_\_ 30s  
 Weight: \_\_\_\_\_ 1,0 kg

CE LVD 2014/35/EU – EMC 2014/30/EU – RoHS 2011/65/EU

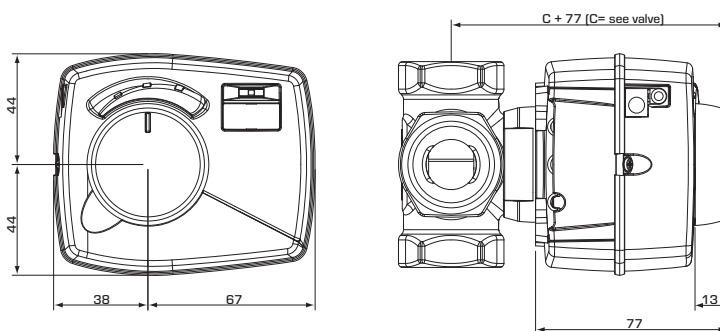

Installation dimensions for Controller Series CRC140 with ESBE VRG100, VRG200, VRG300, VRH100 and VRB100 mixing valves

Art. No.	Reference	Torque [Nm]	Voltage [VAC]	Note
12824100	CRC141	6	230	



### ADDITIONAL GUIDANCE

Accessories..... 88–90  
 Guide & Dimensioning..... 59  
 Installation examples..... 64  
 For further detailed information..... [www.esbe.eu](http://www.esbe.eu)



**CONTROLLER**  
Series CRD100

- **Combined weather compensating and indoor sensor based controller**
- **Inbuilt adaptation to build the perfect heating curve**
- **All adjustments from the wireless room unit**
- **Easy and quick to install**

The ESBE series CRD100 is a combined weather compensating and indoor sensor based controller. The controller include an advanced adaptation that will build the ideal characteristic heating curve for the specific building so that the user only need to decide one thing, the required indoor temperature. The controller consists of three parts, the actuator unit, the room display unit and the outdoor sensor. Room display unit in modern design, which contains the indoor temperature sensor and in which all settings, such as day to day climate adjustments as well as the internal day and weekly program, are set. The actuator unit is designed for operating rotary valves DN 15-50 and has an operating range of 90°.

**TECHNICAL DATA**

Ambient temperature: \_\_\_\_\_ max. +55°C  
 \_\_\_\_\_ min. -5°C  
 Sensors: \_\_\_\_\_ Temperature sensor type NTC  
 Temperature range - Flow pipe sensor: \_\_\_\_\_ +5 to +95°C  
 - Room sensor: \_\_\_\_\_ +5 to +30°C  
 - Outdoor sensor: \_\_\_\_\_ -50 to +70°C  
 ErP Temperature controls class: \_\_\_\_\_ VII  
 Energy efficiency contribution: \_\_\_\_\_ 3,5%  
 Enclosure rating - Actuator unit: \_\_\_\_\_ IP41  
 - Room display unit: \_\_\_\_\_ IP20  
 Protection class: \_\_\_\_\_ II  
 Power supply - Actuator unit: \_\_\_\_\_ 230 ± 10% VAC, 50 Hz  
 - Room display unit - wireless: \_\_\_\_\_ 2x 1,5 V LR6/AA  
 Power consumption - 230 V AC: \_\_\_\_\_ 10 VA  
 Battery endurance, wireless room display unit: \_\_\_\_\_ 1 year  
 Torque: \_\_\_\_\_ 6 Nm  
 Running time at max. speed: \_\_\_\_\_ 30s  
 Radio frequency: \_\_\_\_\_ 868MHz  
 \_\_\_\_\_ ITU region 1 approved acc. to EN 300220-2  
 Weight: \_\_\_\_\_ 1,2 kg

CE LVD 2014/35/EU - EMC 2014/30/EU - RoHS 2011/65/EU

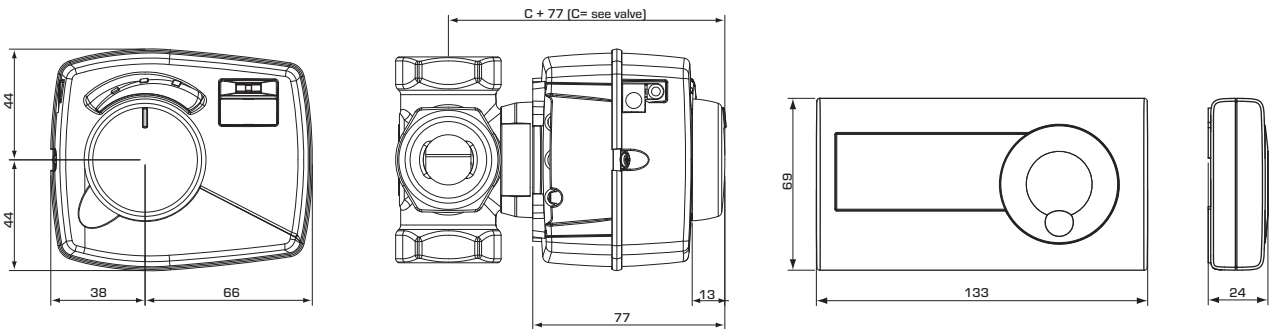

Installation dimensions for Controller Series CRD100 with ESBE VRG100, VRG200, VRG300, VRH100 and VRB100 mixing valves

Installation dimensions for Room display units

Art. No.	Reference	Torque [Nm]	Voltage [VAC]	Room display unit	Note
12682200	CRD122	6	230	Wireless	
12682500	CRD125				Transformer with UK plug



**ADDITIONAL GUIDANCE**

Accessories..... 88-90  
 Guide & Dimensioning..... 59

Installation examples..... 65  
 For further detailed information..... [www.esbe.eu](http://www.esbe.eu)



## CONTROLLER

### Series CRS130

- **Constant temperature controller made especially for potable water applications**
- **Legionella flushing is possible by activation of alternative temperature**
- **Suberb regulation**
- **Controller with integrated actuator**

The ESBE series CRS130 is a combined actuator and constant flow temperature controller for primarily use in centralised potable water applications (PWx) thanks to the response time and position of the sensor. Temperature setting is done by an easy-to-use joystick and display interface and shall be set in accordance with national and local regulations. Adjustable temperature setting within the range of 5 - 95°C. The compact controller is designed for operating rotary valves DN 15-50 and has an operating range of 90°.

#### TECHNICAL DATA

Ambient temperature: \_\_\_\_\_ max. +55°C  
 \_\_\_\_\_ min. -5°C  
 Sensors: \_\_\_\_\_ Temperature sensor type NTC  
 Temperature range - Flow pipe sensor: \_\_\_\_\_ +5 to +95°C  
 Enclosure rating: \_\_\_\_\_ IP41  
 Protection class: \_\_\_\_\_ II  
 Power supply: \_\_\_\_\_ 230 ± 10% V AC, 50 Hz  
 Power consumption - 230 V AC: \_\_\_\_\_ 10 VA  
 Torque: \_\_\_\_\_ 6 Nm  
 Running time at max. speed: \_\_\_\_\_ 30s  
 Weight, CRS131: \_\_\_\_\_ 0,7 kg  
 CRS135: \_\_\_\_\_ 0,8 kg  
 Connection, mounting set: \_\_\_\_\_ External thread (R), EN 10226-1

Material  
 Flow pipe sensor: \_\_\_\_\_ Stainless steel  
 Mounting set flow pipe sensor: \_\_\_\_ Dezincification resistant brass DZR\*

\* Suitable for drinking water applications

CE LVD 2014/35/EU - EMC 2014/30/EU - RoHS 2011/65/EU

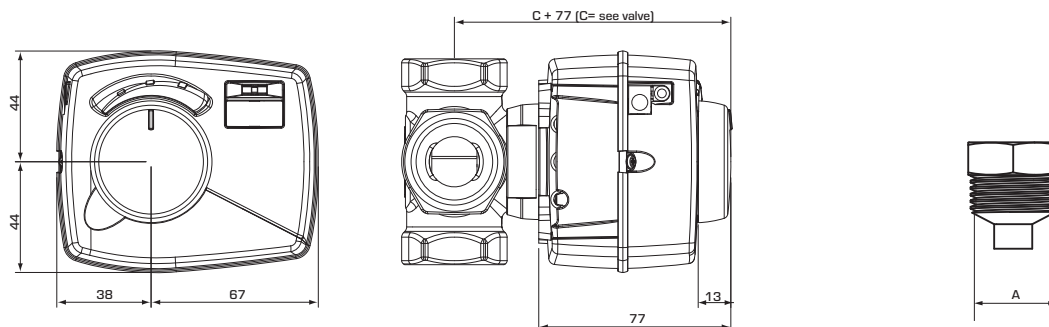

Installation dimensions for Controller Series CRS130 with ESBE VRG100, VRG200, VRG300, VRH100 and VRB100 mixing valves

Mounting set

Art. No.	Reference	Torque [Nm]	Voltage [VAC]	Temp. range	Connection A	Note
12723100	CRS131	6	230	5-95°C	R 1/2"	
12723500	CRS135					Transformer with UK plug



#### ADDITIONAL GUIDANCE

Accessories..... 88-90      Installation examples..... 65  
 Guide & Dimensioning..... 59      For further detailed information..... [www.esbe.eu](http://www.esbe.eu)



**CONTROLLER**  
Series CUA100

- For use with most 3-point 24 VAC actuator
- High level of comfort

Series CUA100 is an indoor based controller to be used with most 3-point 24 VAC actuators. The controller is designed to provide a high level of comfort and at the same time provide energy savings for the house owner. The regulation is based on indoor sensor feedback and is changed by altering the target temperature in the room display unit. Serie CUA100 can also be used for constant flow temperature control.

**TECHNICAL DATA**

Ambient temperature: \_\_\_\_\_ max. +55°C  
 \_\_\_\_\_ min. -5°C  
 Sensors: \_\_\_\_\_ Temperature sensor type NTC  
 Temperature range - Flow pipe sensor: \_\_\_\_\_ +5 to +95°C  
 - Room sensor: \_\_\_\_\_ +5 to +30°C  
 ErP Temperature controls class: \_\_\_\_\_ IV  
 Energy efficiency contribution: \_\_\_\_\_ 2%  
 Enclosure rating - Control box: \_\_\_\_\_ IP54  
 - Room display unit: \_\_\_\_\_ IP20  
 Protection class: \_\_\_\_\_ II  
 Power supply: \_\_\_\_\_ 230 ± 10% VAC, 50 Hz  
 Power supply - Room display unit, wireless: \_\_\_\_\_ 2x 1,5 V LRG/AA  
 Power consumption, 230 VAC: \_\_\_\_\_ 10 VA  
 Battery endurance, wireless room display unit: \_\_\_\_\_ 1 year  
 Running time, recommended: \_\_\_\_\_ 120s (15 - 240s)  
 Radio frequency: \_\_\_\_\_ 868MHz  
 \_\_\_\_\_ ITU region 1 approved acc. to EN 300220-2  
 Weight: \_\_\_\_\_ 0,8 kg  
 Room display unit cable: \_\_\_\_\_ 20m  
 Max. allowed power consumption of actuator  
 with 230 VAC adapter: \_\_\_\_\_ 4 VA  
 Output voltage: \_\_\_\_\_ 3-point, 24 VAC

CE LVD 2014/35/EU - EMC 2014/30/EU - RoHS 2011/65/EU  
 RED 2014/53/EU

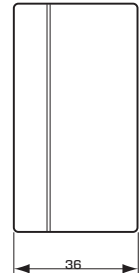
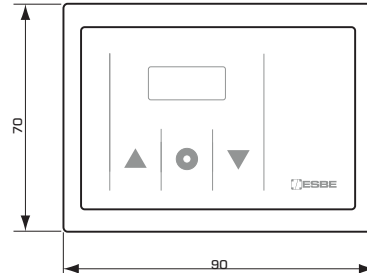
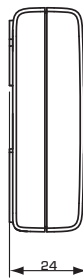
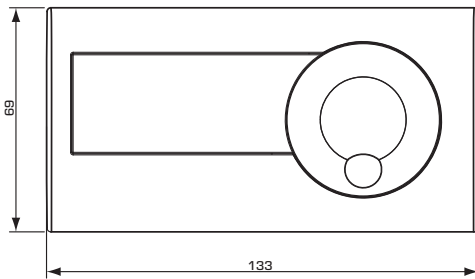

Installation dimensions for Room display unit

Installation dimensions for Control box

Art. No.	Reference	Voltage (VAC)	Room display unit	Note
12640100	CUA111	230	Cable	Without internal timer
12642200	CUA122		Wireless	



**ADDITIONAL GUIDANCE**

Installation examples..... 65

For further detailed information ..... [www.esbe.eu](http://www.esbe.eu)



## CONTROLLER Series 90C

- **Quick and easy mounting**
- **Numerous application possibilities**
- **Different versions to suit different demands**

Series 90C is a complete weather-compensating control unit with integrated actuator for use on mixing valves. The controller comes in 2 different versions, all equipped with full graphic display for easy handling and instant set-up. Depending of version can Series 90C handle up to 6 different sources of data input and has up to 3 possibilities of output control. This makes the 90C versatile and able to control a number of heat circuits and system components with high accuracy.

### Hardware 90C

- = included
- = option, included in versions "C"
- = option, included in versions "A" + "C"

Hardware	Version	
	90C-1	90C-3
Power supply cable (230V), 1.5 m	●	●
Pump / Heat source power supply cable (230V), 1.5 m	●	●
Sensor box	1	2
max. no. of input sources	3	6
max. no. of output sources	1	3
Flow pipe sensor, 1.5 m cable	●	●
Universal sensor, 1.0 m cable [pcs]		3
Outdoor sensor (without cable)	●	●
Room sensor (without cable)	○	○
Sensor cable, 20m	□	□

### TECHNICAL DATA

Basic unit: \_\_\_\_\_ Actuator controller with plastic housing, prewired for supply and sensors

Dimensions (HxWxT): \_\_\_\_\_ approx. 95x135x85 mm

Display: \_\_\_\_\_ fully graphical display 128x64 dots

Light emitting diode: \_\_\_\_\_ polychrome / multicolour

Operation: \_\_\_\_\_ input keys

Power supply: \_\_\_\_\_ 230 ±10% VAC, 50/60 Hz

Power consumption: \_\_\_\_\_ ca 5,0 VA

Total switching capacity of the relay output 1-3: \_\_\_\_\_ 2(0,8)A 250 VAC (circulation pump 185W)

ErP Temperature controls class – 90C-1A, 90C-1B, 90C-3B: \_\_\_\_\_ III  
– 90C-1C, 90C-3C: \_\_\_\_\_ VII

Energy efficiency contribution – 90C-1A, 90C-1B, 90C-3B: \_\_\_\_\_ 1,5%  
– 90C-1C, 90C-3C: \_\_\_\_\_ 3,5%

Enclosure rating: \_\_\_\_\_ IP 54 as per DIN 40050 CE

Protection class: \_\_\_\_\_ II

Ambient temperature: \_\_\_\_\_ 0° to 40°C max.

Ambient atmospheric humidity: \_\_\_\_\_ max. 85% RH at 25°C

Actuator: \_\_\_\_\_ Running time 120 s/90°

Torque: \_\_\_\_\_ 15 Nm

Sensors: \_\_\_\_\_ Temperature sensor type PT1000

Sensor cable: \_\_\_\_\_ 4x0,38mm<sup>2</sup>, max. length 30m

Temperature range:

Flow pipe sensor CRS211, 1,5m \_\_\_\_\_ 0 to +105°C

Outdoor sensor CRS214 \_\_\_\_\_ -50 to +70°C

Universal sensor CRS213 Ø5mm, 1,5m \_\_\_\_\_ 0 to +105°C

Room sensor CRS231 \_\_\_\_\_ +10 to +30°C

High temperature sensor CRS215 \_\_\_\_\_ -50 to +550°C

Weight: \_\_\_\_\_ 0,9 kg

CE LVD 2014/35/EU - EMC 2014/30/EU - RoHS 2011/65/EU

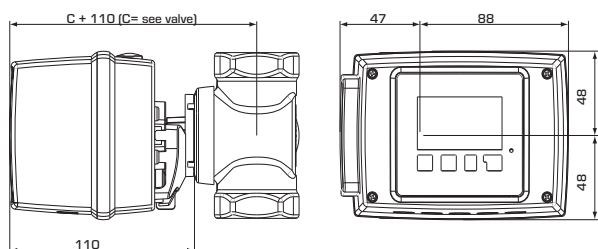

Installation dimensions for Controller Series 90C with ESBE VRG100, VRG200, VRG300, VRH100 and VRB100 mixing valves

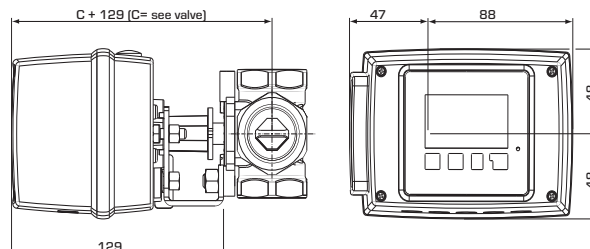

Installation dimensions for Controller Series 90C with ESBE series MG, G, F, T/TM, H/HG and BIV mixing valves

### 90C-1

Art. No.	Reference	Torque [Nm]	Voltage [VAC]	No. of input sources	No. of output sources	Sensor cable enclosed	Room sensor enclosed	Universal sensor	Note
12601500	90C-1A-90	15	230	3	1	●			Operating range 90°
12601600	90C-1B-90								
12601700	90C-1C-90					●	●		

### 90C-3

Art. No.	Reference	Torque [Nm]	Voltage [VAC]	No. of input sources	No. of output sources	Sensor cable enclosed	Room sensor enclosed	Universal sensor	Note
12603600	90C-3B-90	15	230	6	3			3	Operating range 90°
12603700	90C-3C-90					●	●		



### ADDITIONAL GUIDANCE

Accessories..... 88–90      Installation examples..... 66  
 Guide & Dimensioning..... 59–60      For further detailed information ..... www.esbe.eu



## ADAPTOR KITS

Guide for use to ESBE actuators and controllers

- Comes with the actuator
- Order separately



Type Reference	Art. No.		Series ARAGxx, CRA11x, CRA14x, CRA15x, CRB11x, CRB12x, CRC11x, CRC14x, CRD12x, CRS13x	Series 90, CRA12x, CRC12x	Series 90C
<b>ARA803</b> ESBE VRG, VRB, VRH + ESBE MG, G, F, BIV, H, HG	16000500		●		
<b>ARA806</b> Honeywell Centra Corona, Series V5433A, V5433G, V5442A, V5442G	16000800		●		
<b>ARA808</b> Lovato	16000900		●		
<b>ARA805</b> Meibes	16000600		●		
<b>ARA809</b> PAW	16001000		●		
<b>ARA807</b> Watts	16000700		●		
<b>ARA810</b> Wita Minimix, Maximix, H10, H9GG, H9MS	16001100		●		



Type Reference	Art. No.		Series 90	Series ARC300, ARC600, ARD100, ARD200
<b>VBFB01</b> ESBE VBF100	13905100		●	
<b>VBFB02</b> ESBE VBF100	13905200			●

## ADAPTOR KITS

Guide for use to ESBE actuators and controllers

● Comes with the actuator    ● Order separately



Type Reference	Art. No.		Series ARAGxx, CRA11x, CRA14x, CRA15x, CRB11x, CRB12x, CRC11x, CRC14x, CRD12x, CRS13x	Series 90, CRA12x, CRC12x	Series 90C
<b>VRG801</b> ESBE VRG, VRB, VRH	16053300			●	
<b>VRG804</b> ESBE VRG, VRB, VRH without hand lever for controller 90C	16053700				●
<b>900</b> ESBE Serie MG, G, F, BIV, H, HG	16051300			●	
<b>900-270</b> ESBE Serie MG, G without hand lever for actuator 92P4, 95-270M and controller 90C	16053400			●	●
<b>900C</b> Honeywell Centra ZR, DR, DRU, DRG (DN15 - DN50)	16053900			●	●*
<b>900CK</b> Honeywell Centra Kompakt DRK/ZRK	16051700			●	●*
<b>900F</b> Meibes /Oventrop** / Watts/ BRV	16053600			●	●*
<b>900K</b> Siemens VBG31, VBI31, VBF21, VCI31	16052500			●	●*
<b>900A</b> TA-VTR	16051400			●	●*
<b>900L</b> Schneider Electric TRV / TAC-TRV	16052600			●	●*
<b>900B</b> Viessmann (DN20 - DN25)	16051500			●	●*

Notes: \* The adaptor kit comes with a hand lever and for the controller series 90C this must be removed. It is not required for assembly. \*\* until 2015, not for versions without thread in the axis



## VALVE + CONTROLLER

### Series VRx131 + CRx

Valve and controller delivered as a set in an all-in-one package. For more information about the products, please see separate product pages.

#### ADDITIONAL GUIDANCE

Valve series VRB141 .....46    Controller series CRA111 .....76  
 Valve series VRG131 .....41    Controller series CRC111 .....81

#### VRB141 + CRA111

Art. No.	Bivalent mixing valve VRB141				Controller CRA111		Note
	Pressure class	DN	Kvs	Connection	Power supply	Torque [Nm]	
13040100	PN 10	25	10	Rp 1"	230 V AC	6	

#### VRG131 + CRC111

Art. No.	Mixing valve VRG131				Controller CRC111		Note
	Pressure class	DN	Kvs	Connection	Power supply	Torque [Nm]	
13041000	PN 10	20	6,3	Rp 3/4"	230 V AC	6	
13041100		25	10	Rp 1"			

## ESBE ACCESSORIES



### SENSORS

#### Series CRx

Art. No.	Reference	Designation
17053100	CRA911	Flow pipe sensor, 5m cable
17056000	CRC911	Outdoor sensor [CRC, CRD]
17056100	CRC912	Sensor expander

### SENSORS

#### Series 90C

Art. No.	Reference	Designation
17050700	CRS231	Room sensor
17050800	CRS211	Flow pipe sensor
17050900	CRS213	Universal sensor
17051000	CRS214	Outdoor sensor
17051100	CRS215	High temperature sensor

# ROOM THERMOSTATS OPENS UP ADDITIONAL POSSIBILITIES

A series of room thermostats with precise regulation and an offer of different versions for different needs. Combine it with other products from ESBE.



**Guidance to choose room thermostat**

- TPx100** Programmable, cable
- TPx200** Programmable, wireless
- TEA100** Precise regulation, cable
- TMA110** Basic regulation, cable
- TFC100** Fan coil applications, cable

SUITABLE ESBE ACTUATORS												
ROOM THERMOSTAT SERIES	Control signal	ARA600	90	ARC300	ARD100, ARD200	ALG400	VZC/VZD	MBA100	ZRS100	ALF	ALB	ALH
<b>TPx100</b>	2-point	ARA6x5, ARA6x6, ARA6x7, ARA6x8	M97, M98	ARC361, ARC363	ARD155, ARD157, ARD255, ARD257	ALG434, ALG436	•	•	•	-	-	-
<b>TPx200</b>	2-point	ARA6x5, ARA6x6, ARA6x7, ARA6x8	M97, M98	ARC361, ARC363	ARD155, ARD157, ARD255, ARD257	ALG434, ALG436	•	•	•	-	-	-
<b>TEA111, TEA114, TEA117</b>	2-point	ARA6x5, ARA6x6	M97, M98	ARC361	ARD155, ARD255	ALG434	•	•	•	-	-	-
<b>TEA119</b>	2-point	ARA6x5, ARA6x6, ARA6x7, ARA6x8	M97, M98	ARC361, ARC363	ARD155, ARD157, ARD255, ARD257	ALG434, ALG436	•	•	•	-	-	-
<b>TEA128</b>	Prop.	ARA639, ARA659	M92P, M92P2, M92P4	ARC368, ARC369	ARD169, ARD269	ALG438	-	-	-	•	•	•
<b>TMA115, TMA116, TMA117</b>	2-point	ARA6x5, ARA6x6, ARA6x7, ARA6x8	M97, M98	ARC361, ARC363	ARD155, ARD157, ARD255, ARD257	ALG434, ALG436	•	•	•	-	-	-
<b>TFC100</b>	2-point	-	-	-	-	ALG434, ALG436	-	•	•	-	-	-
<b>TFC100</b>	Prop.	-	-	-	-	ALG438	-	-	-	•	•	•



**ROOM THERMOSTAT**  
 Series TPx100

- For use in heating or cooling application
- Programmable with day and night settings
- **TPH114 with dew point control**
- Easy installation

The ESBE series TPx100 is a range of programmable ON/OFF electronic room thermostats for use in heating or cooling applications. The thermostats can be connected to 2-point or spring return actuator, a circulation pump or directly to the boiler.

**TECHNICAL DATA**

Ambient temperature: \_\_\_\_\_ max. 40°C  
 \_\_\_\_\_ min. 0°C  
 Ambient humidity: \_\_\_\_\_ 20...80% RH non-condensating  
 Sensor type temperature – TPx100: \_\_\_\_\_ NTC 10 kΩ@25°C  
 Sensor type humidity – TPH114: \_\_\_\_\_ SHT-21  
 ErP Temperature controls class: \_\_\_\_\_ I  
 Energy efficiency contribution: \_\_\_\_\_ 1%  
 Enclosure rating: \_\_\_\_\_ IP30  
 Contact rating: \_\_\_\_\_ 5(1)A @ 250V AC  
 Power supply: \_\_\_\_\_ 2 x 1,5V LR6/AA  
 Battery endurance: \_\_\_\_\_ >1 year  
 Protection class: \_\_\_\_\_ II  
 Material  
 Housing: \_\_\_\_\_ ABS + PC self-extinguishing VO

CE LVD 2014/35/EU – EMC 2014/30/EU – RoHS 2011/65/EU

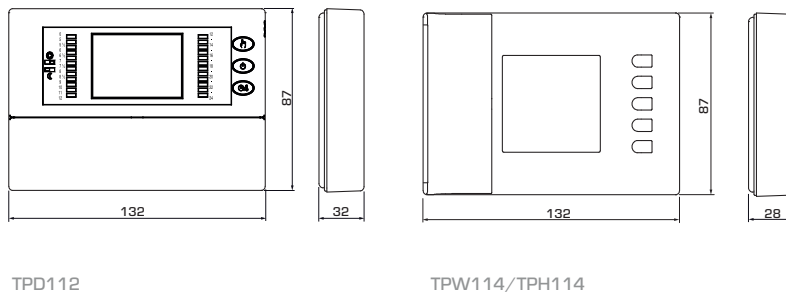

Art. No.	Reference	Application	Setting range	Weight [kg]	Note
18002100	TPD112	Heating or cooling	10–30°C	0,18	Daily programmable
18002200	TPW114		5–40°C	0,17	Weekly programmable
18002300	TPH114	Heating or cooling with humidification/dehumidification function	5–40°C	0,18	Weekly programmable thermo-hygrostat



**ROOM THERMOSTAT**  
 Series TPx200

- **Wireless communication between room thermostat and receiver**
- For use in heating or cooling application
- Easy installation

The ESBE series TPx200 is a range of wireless ON/OFF electronic room thermostats for use in heating or cooling applications. The thermostats can be connected to 2-point or spring return actuator, a circulation pump or directly to the boiler.

**TECHNICAL DATA**

Ambient temperature: \_\_\_\_\_ max. 40°C  
 \_\_\_\_\_ min. 0°C  
 Ambient humidity: \_\_\_\_\_ 20...80% RH non-condensating  
 Sensor type: \_\_\_\_\_ NTC 4,7 kΩ@25°C  
 ErP Temperature controls class: \_\_\_\_\_ I  
 Energy efficiency contribution: \_\_\_\_\_ 1%  
 Enclosure rating – Room thermostats: \_\_\_\_\_ IP30  
 – Receiver: \_\_\_\_\_ IP4x  
 Contact rating: \_\_\_\_\_ 6(1)A @ 250V AC  
 Power supply, Room thermostats: \_\_\_\_\_ 2 x 1,5V LR6/AA  
 Battery endurance: \_\_\_\_\_ >2,5 years  
 Power supply, Receiver: \_\_\_\_\_ 230±10%V AC, 50Hz  
 Power consumption: \_\_\_\_\_ 11W  
 Radio frequency: \_\_\_\_\_ 868MHz  
 Maximum receiver distance: \_\_\_\_\_ >300 meter in free air  
 \_\_\_\_\_ >50 meter in buildings  
 (dependent on the building and environment)  
 Protection class: \_\_\_\_\_ II  
 Material  
 Housing – Room thermostats: \_\_\_\_\_ ABS + PC self-extinguishing VO  
 – Receiver: \_\_\_\_\_ ABS self-extinguishing VO

CE LVD 2014/35/EU – EMC 2014/30/EU – RoHS 2011/65/EU  
 RED 2014/53/EU

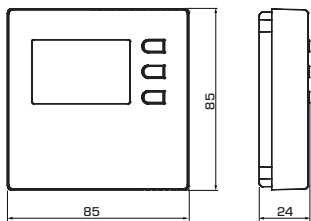

TPE214, Room thermostat

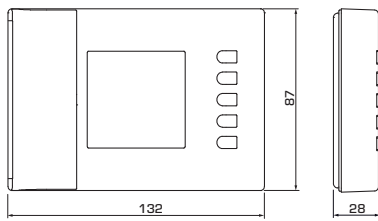

TPD214, Room thermostat

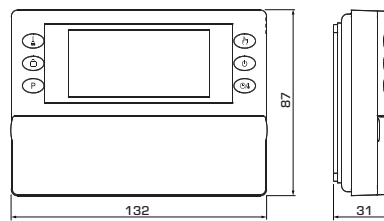

TPW214, Room thermostat

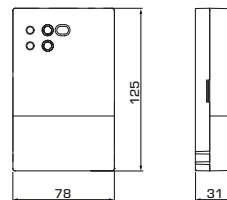

TWR911, Receiver

Art. No.	Reference	Application	Setting range	Weight [kg]	Note
18003100	TPE214	Heating or cooling	5-35°C	0,08+0,16	
18003200	TPD214			0,16+0,16	Daily programmable
18003300	TPW214			0,18+0,16	Weekly programmable thermo-hygrostat



TMA111

TMA112

TMA113

## ROOM THERMOSTAT

### Series TMA110

- **Setting range between 8°C and 30°C**
- **Easy installation**
- **Affordable products**

The ESBE series TMA 110 is a range of ON/OFF electro-mechanical room thermostats for use in heating or cooling applications. The thermostats can be connected to 2-point or spring return actuator, a circulation pump or directly to a boiler.

#### TECHNICAL DATA

Ambient temperature: \_\_\_\_\_ max. 40°C  
 \_\_\_\_\_ min. 0°C  
 Ambient humidity: \_\_\_\_\_ 20..80% RH non-condensating  
 Setting range: \_\_\_\_\_ see table  
 Sensor type: \_\_\_\_\_ Gas filled bellows  
 Differential/ hysteresis: \_\_\_\_\_ <1°K  
 ErP Temperature controls class: \_\_\_\_\_ I  
 Energy efficiency contribution: \_\_\_\_\_ 1%  
 Enclosure rating: \_\_\_\_\_ IP30  
 Contact rating – TMA115: \_\_\_\_\_ 16(2,5)A @ 250V AC  
 TMA116, TMA117: \_\_\_\_\_ 10(1,5)A @ 250V AC  
 Protection class: \_\_\_\_\_ II  
 Material \_\_\_\_\_  
 Housing: \_\_\_\_\_ ABS plastic self-extinguishing V0

CE LVD 2014/35/EU - EMC 2014/30/EU - RoHS 2011/65/EU

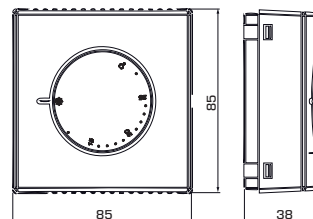

Art. No.	Reference	Application	Setting range	Weight [kg]	Note
18000500	TMA115	Heating	8-30°C	0,11	
18000600	TMA116			0,12	ON/OFF switch
18000700	TMA117	Heating or cooling		0,12	Heating/Cooling switch



#### ADDITIONAL GUIDANCE

For further detailed information ..... [www.esbe.eu](http://www.esbe.eu)



**ROOM THERMOSTAT**  
 Series TEA100

- **Precise regulation**
- **Different versions for different needs**
- **Easy installation**

The ESBE series TEA100 is a range of ON/OFF electronic room thermostats for use in heating or cooling applications. The thermostats can be connected to 2-point or spring return actuator, a circulation pump or directly to a boiler.

**TECHNICAL DATA**

Ambient temperature: \_\_\_\_\_ max. 40°C  
 \_\_\_\_\_ min. 0°C  
 Ambient humidity: \_\_\_\_\_ 20...80% RH non-condensating  
 Regulating range: \_\_\_\_\_ see table  
 Sensor type — TEA111, TEA114, TEA117: \_\_\_\_\_ NTC 4,7 kΩ@25°C  
 — TEA119: \_\_\_\_\_ NTC 10 kΩ@25°C  
 — TEA128: \_\_\_\_\_ PTC 2 kΩ@25°C  
 Differential/ hysteresis — TEA111, TEA114, TEA117: \_\_\_\_\_ 0,5°K  
 — TEA119: \_\_\_\_\_ 0,2°K  
 — TEA128: \_\_\_\_\_ 0,5°K  
 ErP Temperature controls class — TEA11x: \_\_\_\_\_ I  
 — TEA128: \_\_\_\_\_ VI  
 Energy efficiency contribution — TEA11x: \_\_\_\_\_ 1%  
 — TEA128: \_\_\_\_\_ 3%  
 Enclosure rating: \_\_\_\_\_ IP30  
 Contact rating — TEA11x: \_\_\_\_\_ 5(1)A @ 250V AC  
 Power supply  
 — TEA111, TEA114, TEA117: \_\_\_\_\_ 230 -15/+10% V AC, 50Hz  
 — TEA119: \_\_\_\_\_ 2 x 1,5V LRG/AA  
 — TEA128: \_\_\_\_\_ 24 ±10% V AC/DC, 50Hz  
 Power consumption — TEA111, TEA114, TEA117: \_\_\_\_\_ 5,3VA  
 — TEA128: \_\_\_\_\_ 0,7VA  
 Battery endurance — TEA119: \_\_\_\_\_ >4 years  
 Protection class: \_\_\_\_\_ II

Material  
 Housing TEA111/TEA114/TEA117/TEA128: \_\_\_\_\_ ABS plastic self-extinguishing VO  
 Housing TEA119: \_\_\_\_\_ ABS + PC self-extinguishing VO

CE LVD 2014/35/EU – EMC 2014/30/EU – RoHS 2011/65/EU

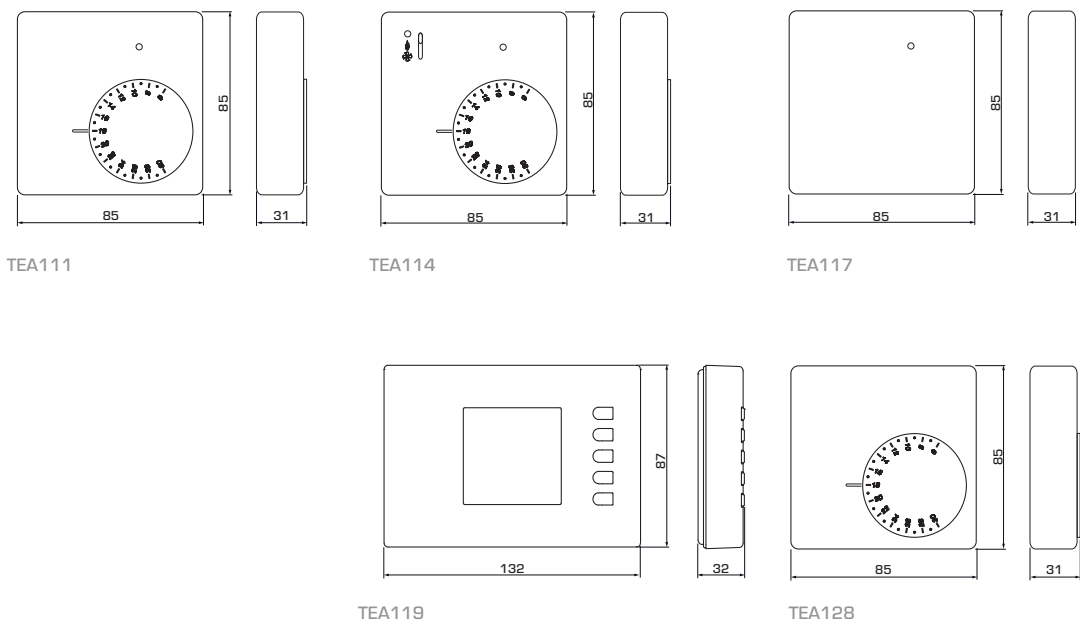

Art. No.	Reference	Application	Setting range	Weight [kg]	Note
18001100	TEA111	Heating	6-30°C	0,10	
18001200	TEA117			0,10	Tamperproof version of TEA111
18001300	TEA114	Heating or cooling	6-30°C	0,11	Heating/Cooling/OFF switch
18001400	TEA128			0,11	0-10V DC control signal
18001500	TEA119			5-35°C	0,17



**ADDITIONAL GUIDANCE**

For further detailed information ..... [www.esbe.eu](http://www.esbe.eu)





## ROOM THERMOSTAT Series TFC100

- Both 24V and 230V versions available
- Different versions for different needs
- For use with 2-pipes or 4-pipes fan coils
- Regulating range between 5°C and 30°C

The ESBE series TFC100 is a range of fan coil room thermostats for use in heating or cooling applications. The thermostats can be connected to 2-point or spring return actuator and fan.

### TECHNICAL DATA

Ambient temperature: \_\_\_\_\_ max. 40°C  
 \_\_\_\_\_ min. 0°C  
 Ambient humidity: \_\_\_\_\_ 20..80% RH non-condensating  
 Regulating range: \_\_\_\_\_ 5-35°C  
 Sensor type: \_\_\_\_\_ NTC 10kΩ@25°C  
 ErP Temperature controls class – TFC11x, TFC12x: \_\_\_\_\_ I  
 – TFC139 \_\_\_\_\_ V  
 Energy efficiency contribution – TFC11x, TFC12x: \_\_\_\_\_ 1%  
 – TFC139 \_\_\_\_\_ 3%  
 Enclosure rating: \_\_\_\_\_ IP30  
 Contact rating: \_\_\_\_\_ see table  
 Power supply – TFC11x: \_\_\_\_\_ 230-15/+10%V AC, 50Hz  
 – TFC11x: \_\_\_\_\_ 24-15/+10%V AC, 50Hz  
 – TFC139 \_\_\_\_\_ 230-15/+10%V AC, 50Hz or  
 \_\_\_\_\_ 24-15/+10%V AC, 50Hz  
 Power consumption – TFC111, TFC12x: \_\_\_\_\_ 1 VA  
 – TFC112: \_\_\_\_\_ 7,7 VA  
 – TFC139 \_\_\_\_\_ 1,2 VA  
 Protection class: \_\_\_\_\_ II

Material \_\_\_\_\_  
 Housing: \_\_\_\_\_ ABS + PC self-extinguishing VO

CE LVD 2014/35/EU – EMC 2014/30/EU – RoHS 2011/65/EU

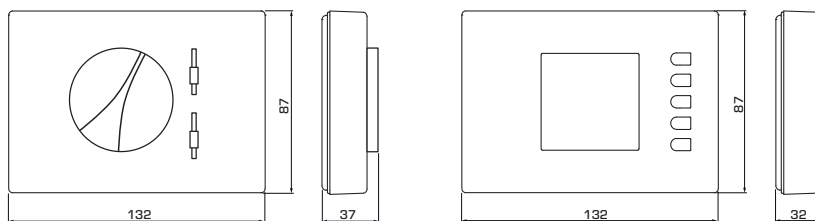

TFC111, TFC112, TFC121, TFC122

TFC139

Art. No.	Reference	Application	Setting range	Weight [kg]	Note
18004100	TFC111	Heating or cooling	5-35°C	0,17	2-pipes system
18004200	TFC121			0,17	2-pipes system
18004300	TFC112	Heating and cooling	5-35°C	0,18	4-pipes system
18004400	TFC122			0,18	4-pipes system
18004500	TFC139			0,19	0-10V DC control signal



### ADDITIONAL GUIDANCE

For further detailed information ..... [www.esbe.eu](http://www.esbe.eu)

## FAN COIL VALVES & ACTUATORS COMPACT AND EASY TO INSTALL

**Compact design** for control of heated or chilled water in fan coil systems.



### RUNNING TIME

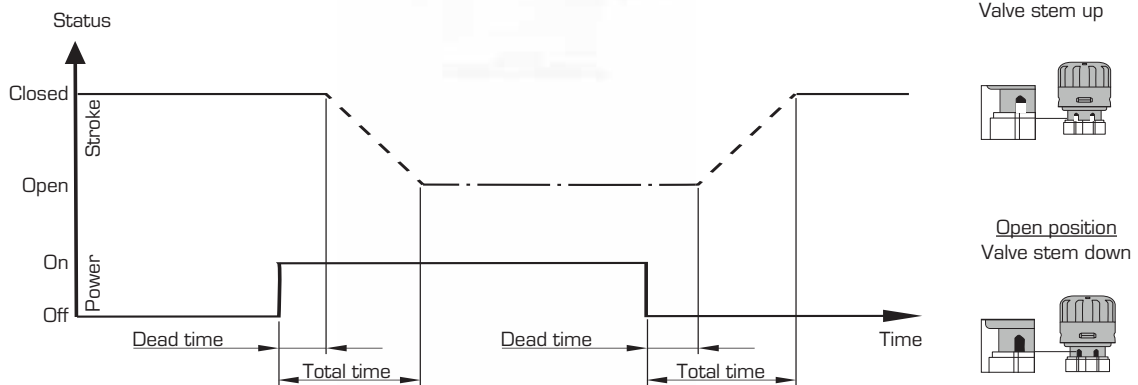

Actuator timing details (approx.)

Actuator	Voltage [V]	Valve opening		Valve closing (after 5 minutes power on)		Valve closing (after 30 minutes power on)	
		Dead time [s]	Total time [s]	Dead time [s]	Total time [s]	Dead time [s]	Total time [s]
ALG434	230	80	230	180	390	150	400
	110	100	380	80	330	80	330
ALG436/ALG438	24	150	400	180	390	150	400

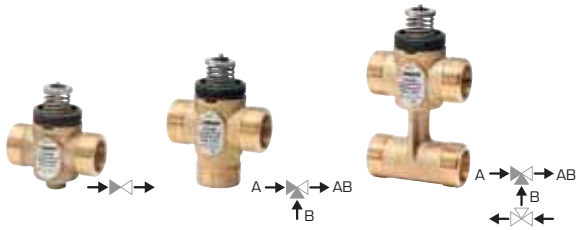

## FAN COIL VALVE

### Series VLG100

- Perfect match between the valve and ESBE actuator Series ALG400
- Compact and easy to install
- Different Kvs values available

ESBE Valve Series VLG100 is a linear valve suitable for the control of heated and chilled water in heating, air-conditioning plants and fan coil units. Valves are motorized by ALG400 (thermo-electrical actuator) and the actuator-valve assembly is easily made thanks to the threaded ring nut. VLG100 has compact dimensions to enable an easy mounting within limited spaces for example on terminal unit coils.

The valves are available in 2-way, 3-way or 3-way with by-pass versions and are normally closed (NC) without actuator, i.e. stem is closing upwards. The combination with ESBE actuator ALG400 is also normally closed (NC) with stem going upwards.

#### TECHNICAL DATA

Pressure class: PN 16  
 Stroke: 2,5 mm  
 Leakage: 0%  
 Temperature: max. +95°C  
 min. +5°C  
 Media: water  
 water/glycol mixtures, max. 50%  
 Connection: External thread (G), ISO 228/1  
 Material  
 Body: Brass CW617N  
 Stem: PPS, GF50%  
 Seallings, O-ring: EPDM  
 Spring: Stainless steel

CE PED 2014/68/EU, article 4.3

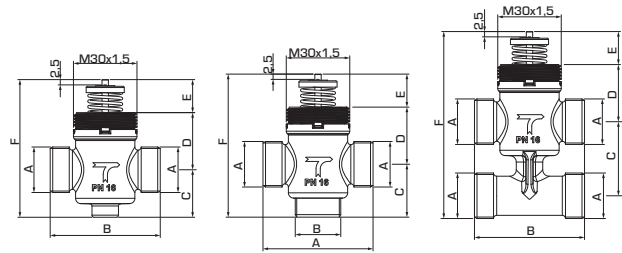

VLG122

VLG132

VLG142

#### VLG122 2-Way

Art. No.	Reference	DN	Kvs	A	B	C	D	E	F	Weight [kg]	Note
21500100	VLG122	15	0,25	G 1/2"	52	23	27	16	65	0,12	
21500200			0,4							0,12	
21500300			0,63							0,12	
21500400			1							0,12	
21500500			1,6							0,12	
21500600			2,5							0,15	
21500700	20	G 3/4"	4	56	24	26	16	65	0,38		
21500800			6,3						0,36		

#### VLG132 3-Way

Art. No.	Reference	DN	Kvs A	Kvs B	ΔP	A	B	C	D	E	F	Weight [kg]	Note
21501100	VLG132	15	0,25	0,25	4,0	G 1/2"	52	23	27	16	65	0,13	
21501200			0,4	0,4	4,0							0,13	
21501300			0,63	0,63	4,0							0,13	
21501400			1	0,63	3,5							0,13	
21501500			1,6	1	3,5							0,13	
21501600			2,5	1,6	3,5							0,17	
21501700	20	G 3/4"	4	2,5	1,0 (0,4)	56	24	26	16	65	0,41		
21501800			6,3	4	1,0 (0,4)						0,40		

#### VLG142 3-Way valve with by-pass

Art. No.	Reference	DN	Kvs A	Kvs B	ΔP	A	B	C	D	E	F	Weight [kg]	Note
21502100	VLG142	15	0,25	0,25	4,0	G 1/2"	52	35	27	16	88	0,20	
21502200			0,4	0,4	4,0							0,20	
21502300			0,63	0,63	4,0							0,20	
21502400			1	0,63	3,5							0,20	
21502500			1,6	1	3,5							0,20	
21502600			2,5	1,6	3,5							0,27	
21502700	20	G 3/4"	4	2,5	1,0 (0,4)	56	50	26	16	98	0,52		
21502800			6,3	4	1,0 (0,4)						0,51		



#### ADDITIONAL GUIDANCE

Guide & Dimensioning..... 96, 99–100  
 Installation examples..... 100

For further detailed information ..... [www.esbe.eu](http://www.esbe.eu)



## ACTUATOR Series ALG400

- Perfect match between the actuator and ESBE valves Series VLG100
- Different control signal available
- Easy assembly thanks to the threaded ring nut
- Stroke indicator on actuator

The ESBE Series ALG400 is a thermo-electrical actuator suitable for fan coil valves such as ESBE Series VLG100 in both heating and cooling applications. The actuator has a force of 140N and an operating stroke of 2.5 mm. The actuator -valve assembly is easily made thanks to the threaded ring nut.

The actuator is available in 24V AC/DC or 230V AC versions with 2-point or in 24V AC version with proportional control signal.

### TECHNICAL DATA

Ambient temperature: \_\_\_\_\_ max. 50°C  
 \_\_\_\_\_ min. 2°C  
 Enclosure rating: \_\_\_\_\_ IP 44 (vertical mounting)  
 Protection class: \_\_\_\_\_ II  
 Power supply, ALG434: \_\_\_\_\_ 110-230V AC, 50/60 Hz  
 ALG436: \_\_\_\_\_ 24V AC, 50/60 Hz; 24V DC  
 ALG438: \_\_\_\_\_ 24V AC, 50/60 Hz  
 Power consumption - starting, ALG434: \_\_\_\_\_ 50W (230V)  
 ALG434: \_\_\_\_\_ 12W (110V)  
 ALG436: \_\_\_\_\_ 4W  
 ALG438: \_\_\_\_\_ 5W  
 Power consumption - operating: \_\_\_\_\_ 1,8W  
 Control signal, ALG434/ALG436: \_\_\_\_\_ 2-point  
 ALG438: \_\_\_\_\_ 0-10V DC  
 Running time: \_\_\_\_\_ see page 96  
 Stroke: \_\_\_\_\_ 2,5 mm  
 Force: \_\_\_\_\_ 140 N  
 Weight, ALG434/ALG436: \_\_\_\_\_ 0,15 kg  
 ALG438: \_\_\_\_\_ 0,17 kg

Material: \_\_\_\_\_ Technopolymer case self-extinguishing VO

CE LVD 2014/35/EU - EMC 2014/30/EU - RoHS 2011/65/EU

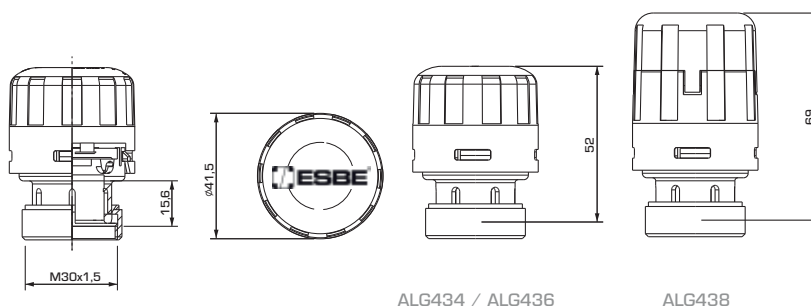

### ALG43X 2-point, Stroke 2,5 mm

Art. No.	Reference	Supply voltage [V]	Force [N]	Power consumption		Note
				starting	operating	
22500100	ALG434	110-230V AC	140	50W (230V) 12W (110V)	1,8W	
22500200	ALG436	24V AC/DC		4W		

### ALG438 Proportional, Stroke 2,5 mm

Art. No.	Reference	Supply voltage [V]	Force [N]	Power consumption		Note
				starting	operating	
22500300	ALG438	24V AC	140	5W	1,8W	



### ADDITIONAL GUIDANCE

Guide & Dimensioning ..... 96

For further detailed information ..... [www.esbe.eu](http://www.esbe.eu)

# FAN COIL VALVES & ACTUATORS

## VALVE CHARACTERISTICS

— Port A  
— Port B

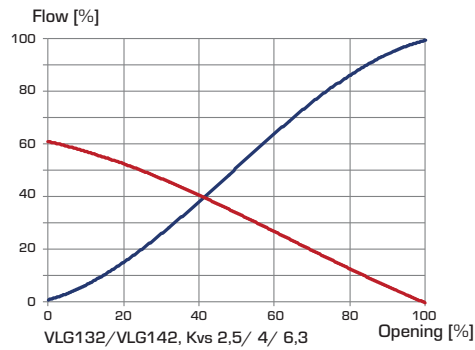
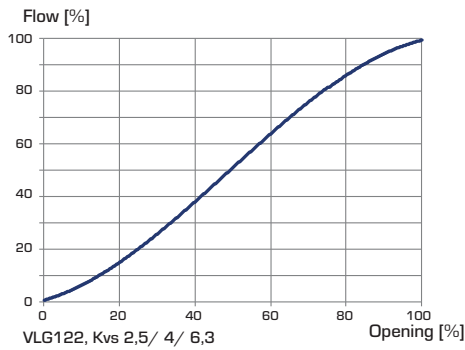
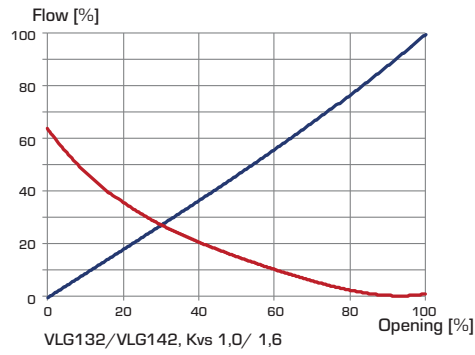
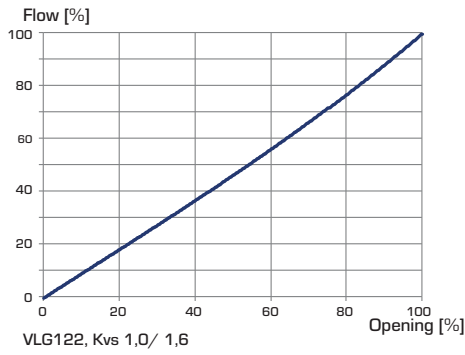
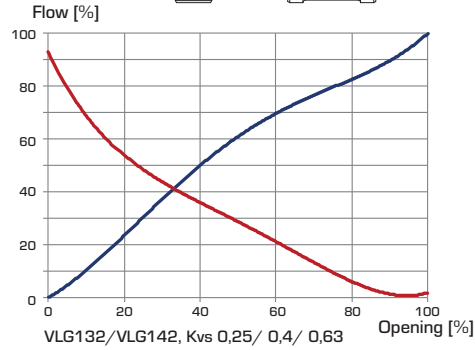
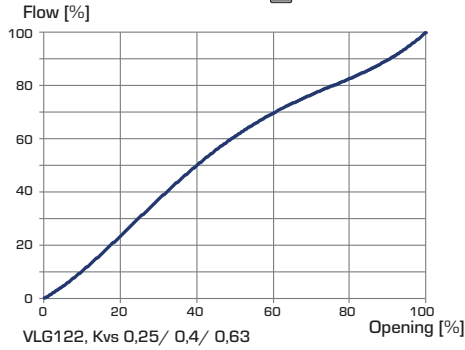
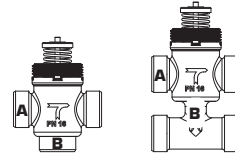
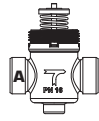

### VALVE MOUNTING

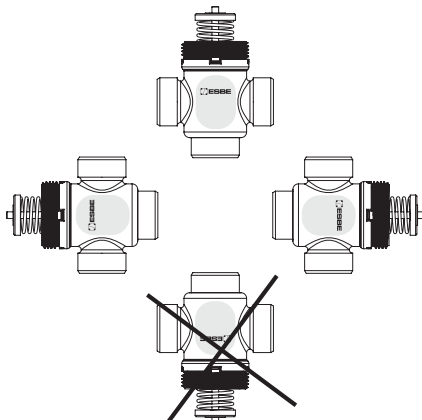

# FAN COIL VALVES & ACTUATORS DIMENSIONING

**FLOW CHART**

To be considered: As both the viscosity and the thermal conduction are affected when glycol is added to the system water, this fact has to be considered when dimensioning the valve.

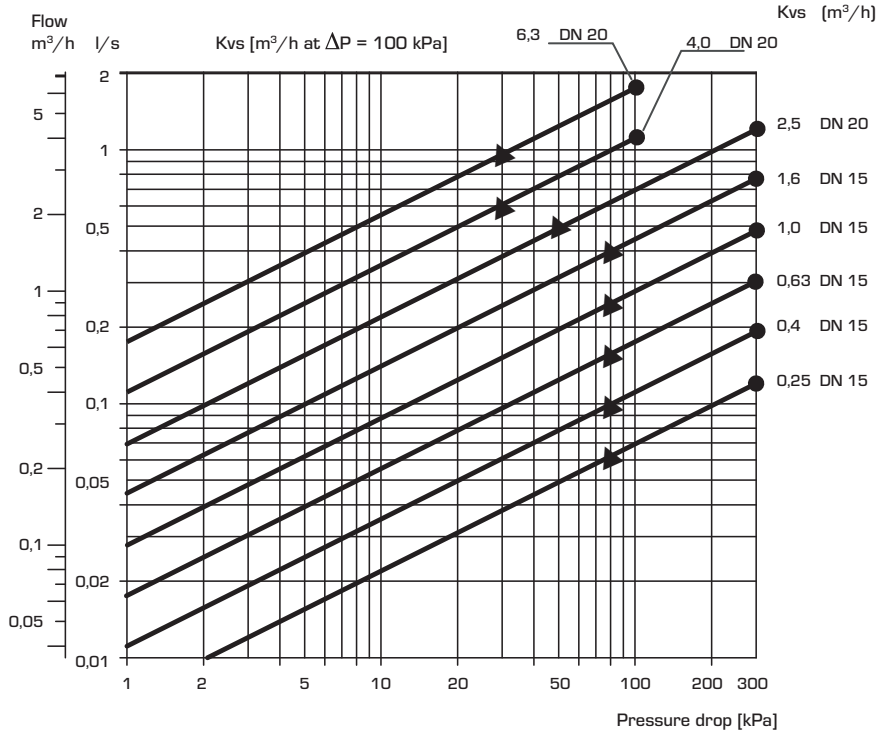

- = max differential pressure drop allowed in mixing function
- ▲ = max differential pressure drop allowed in diverting function

**INSTALLATION EXAMPLES**

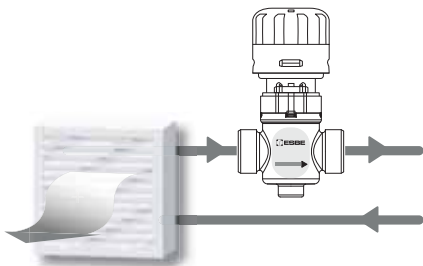

VLG122

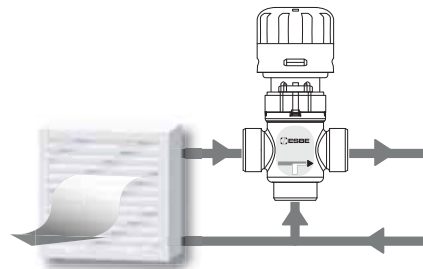

VLG132

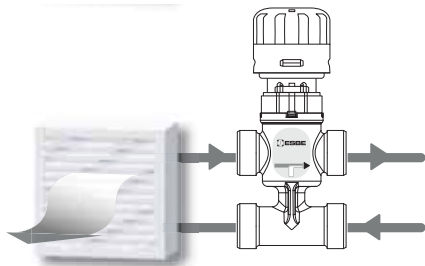

VLG142

# SOLID FUEL PRODUCTS FIRING WITH SOLID FUEL CAN BE A CHALLENGE

**ESBE solid fuel products have been developed** primarily to ensure easier installation and regulation. They automatically loads accumulation tanks and protects solid fuel boilers from low return temperatures.





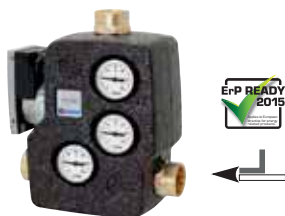

**LOAD UNIT**  
Series LTC200

- **Accurate control of the return water temperature**
- **Fully adjustable pump speed to optimize the storage tank loading**
- **High efficiency pump according to the new ErP directive**
- **Integrated venting function**

The series LTC200 is a load unit with integrated high efficiency pump. The load unit makes sure that the boiler gets up to a high combustion temperature so as to ensure the lowest possible emissions. Above all, the load unit make sure that the return temperature to the boiler is kept high and guaranteed over the entire combustion cycle which enables a higher level of boiler efficiency, reduced tarring and increased life span of the boiler. The high efficiency pump included in the load unit fulfills the new EU directive on energy related products. This directive defines the standardized requirements for energy efficiency and maximizes the EEI (Energy Efficiency Index) to 0.23.

**TECHNICAL DATA**

Pressure class: \_\_\_\_\_ PN 6  
 Temperature of medium: \_\_\_\_\_ max. 110°C  
 \_\_\_\_\_ min. 0°C  
 Ambient temperature: \_\_\_\_\_ max. 60°C  
 \_\_\_\_\_ min. 0°C  
 Leakrate A - AB: \_\_\_\_\_ max. 0,5% of max. flow (Qmax)  
 Leakrate B - AB: \_\_\_\_\_ max. 3% of max. flow (Qmax)  
 Rangeability Kv/Kv<sup>min</sup>: \_\_\_\_\_ 100  
 Supply voltage: \_\_\_\_\_ 230 ± 10% VAC, 50 Hz  
 Power consumption: \_\_\_\_\_ LTC261, 3 - 45W  
 \_\_\_\_\_ LTC271, 3 - 76W  
 Energy classification: \_\_\_\_\_ A  
 EEI (Energy Efficiency Index) \_\_\_\_\_ <0,23  
 Power supply cable: \_\_\_\_\_ 0,1 m  
 Connections: \_\_\_\_\_ Internal thread (G), EN 10226-1  
 Material  
 Valve body and cover: \_\_\_\_\_ Nodular iron EN-JS 1050  
 Insulation: \_\_\_\_\_ EPP black 35g/l  
 Conformities and certificates:  
 PED 2014/68/EU, article 4.3  
 CE LVD 2014/35/EU ErP 2009/125/EU  
 EMC 2014/30/EU ErP 2015  
 RoHS 2011/65/EU

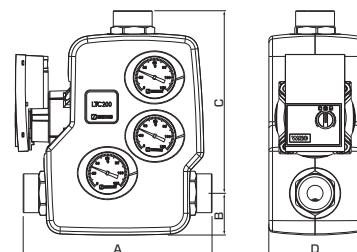

**LTC261** Internal thread with electronic 6 m pump

Art. No.	Reference	DN	Connection Adapter	Power* [kW] (max. Δt)	Opening Temperature	A	B	C	D	Weight (kg)	
55004000	LTC261	25	G 1"	95	35	207	50	209	110	4,4	
55004100				80	30						55°C ± 5°C
55004200				65	25						60°C ± 5°C
55004300				55	20						65°C ± 5°C
55004400	LTC261	32	G 1¼"	95	35	227	50	219	110	4,6	
55004500				80	30						60°C ± 5°C
55004600				65	25						65°C ± 5°C
55004700				55	20						70°C ± 5°C
55004800	LTC261	40	G 1½"	95	35	241	50	226	110	4,6	
55004900				80	30						55°C ± 5°C
55005000				65	25						60°C ± 5°C
55005100				55	20						65°C ± 5°C

**LTC271** Internal thread with electronic 7.5 m pump

Art. No.	Reference	DN	Connection Adapter	Power* [kW] (max. Δt)	Opening Temperature	A	B	C	D	Weight (kg)	
55007100	LTC271	40	G 1½"	130	40	241	50	226	110	4,6	
55007200				115	35						50°C ± 5°C
55007300				100	30						55°C ± 5°C
55007400				80	25						60°C ± 5°C
55007500				65	20						65°C ± 5°C
55007600	LTC271	50	G 2"	130	40	246	50	228	110	6,0	
55007700				115	35						50°C ± 5°C
55007800				100	30						55°C ± 5°C
55007900				80	25						60°C ± 5°C
55008000				65	20						65°C ± 5°C



**ADDITIONAL GUIDANCE**

Accessories..... 108 Installation examples..... 111  
 Guide & Dimensioning..... 109 For further detailed information ..... www.esbe.eu

\* The following recommendations apply only for this product. For the overall system requirements, restrictions in the possible power output can occur, (available Δp = 15 kPa).



## LOAD VALVE Series VTC500

- **Accurate control of the return water temperature.**
- **Easy installation. No need of adjustment valve.**
- **The series VTC530 includes shut off valves and insulation. Just add the best suitable pump.**
- **Easy but normally not required maintenance.**

The series VTC500 is a thermic valve used for solid fuel boilers up to 150 kW. The load valve makes sure that the boiler gets up to a high combustion temperature so as to ensure the lowest possible emissions. Above all, the valves make sure that the return temperature to the boiler is kept high and guaranteed over the entire combustion cycle which enables a higher level of boiler efficiency, reduced tarring and increased life span of the boiler.

### TECHNICAL DATA

Pressure class: \_\_\_\_\_ Series VTC510, PN 10  
 \_\_\_\_\_ Series VTC530, PN 6  
 Temperature of medium: \_\_\_\_\_ max 110°C  
 \_\_\_\_\_ min 0°C  
 Max. differential pressure: \_\_\_\_\_ 100 kPa (1,0 bar)  
 Max. differential pressure A - B: \_\_\_\_\_ 30 kPa (0,3 bar)  
 Leakrate A - AB: \_\_\_\_\_ max 1% of Kvs  
 Leakrate B - AB: \_\_\_\_\_ max 3% of Kvs  
 Rangeability Kv/Kv<sup>min</sup>: \_\_\_\_\_ 100  
 Connections: \_\_\_\_\_ Internal thread (G), ISO 228/1  
 \_\_\_\_\_ Internal thread (Rp), EN 102261-1  
 \_\_\_\_\_ External thread (G), ISO 228/1  
 Material  
 Valve body and cover: \_\_\_\_\_ Nodular iron EN-JS 1050  
 Insulation: \_\_\_\_\_ EPP black 35g/l  
 PED 2014/68/EU, article 4.3

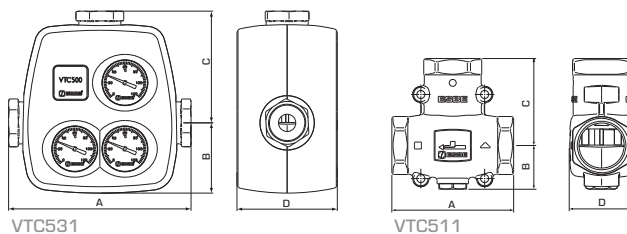

### VTC531 Internal thread

Art. No.	Reference	DN	Kvs	Connection	Opening Temperature	A	B	C	D	Weight [kg]
51025600	VTC531	25	8	G 1"	55°C ± 4°C	197	77	121	110	2,0
51025700					60°C ± 4°C					
51025800					70°C ± 4°C					
51026000	VTC531	32	8	G 1 1/4"	50°C ± 4°C	230	77	138	110	2,2
51026100					55°C ± 4°C					
51026200					60°C ± 4°C					
51026500	VTC531	40	8	G 1 1/2"	50°C ± 4°C	242	77	143	110	2,3
51026600					55°C ± 4°C					
51026700					60°C ± 4°C					
51027000	VTC531	50	12	G 2"	50°C ± 4°C	260	77	152	110	2,6
51027100					55°C ± 4°C					
51027200					60°C ± 4°C					
51027800					65°C ± 4°C					

### VTC511 Internal thread

Art. No.	Reference	DN	Kvs	Connection	Opening Temperature	A	B	C	D	Weight [kg]
51020100	VTC511	25	9	Rp 1"	50°C ± 5°C	93	34	69	47	0,84
51020200					55°C ± 5°C					
51020300					60°C ± 5°C					
51021100					65°C ± 5°C					
51020400					70°C ± 5°C					
51020600	VTC511	32	14	Rp 1 1/4"	50°C ± 4°C	105	38	75	55	1,38
51020700					55°C ± 4°C					
51020800					60°C ± 4°C					
51021200					65°C ± 4°C					
51020900					70°C ± 4°C					

SEE NEXT PAGE FOR MORE TABLES »



### ADDITIONAL GUIDANCE

Accessories..... 108      Installation examples..... 111  
 Guide & Dimensioning..... 110      For further detailed information ..... www.esbe.eu

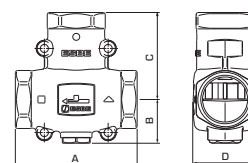

**VTC512** External thread

Art. No.	Reference	DN	Kvs	Connection	Opening Temperature	A	B	C	D	Weight [kg]
51021500	VTC512	25	9	G 1¼"	50°C ± 5°C	93	34	69	47	0,80
51021600					55°C ± 5°C					
51021700					60°C ± 5°C					
51022500					65°C ± 5°C					
51021800					70°C ± 5°C					
51022000	VTC512	32	14	G 1½"	50°C ± 4°C	105	38	75	55	1,31
51022100					55°C ± 4°C					
51022200					60°C ± 4°C					
51022600					65°C ± 4°C					
51022300					70°C ± 4°C					

**FOR MORE VERSIONS .....WWW.ESBE.EU**



**LOAD VALVE**  
Series VTC400

- **Accurate control of the return water temperature**
- **High kvs value**
- **Available fixed and adjustable temperature setting**
- **Wide range of temperatures**

The ESBE thermic valve series VTC400 are designed for applications with boilers, which require return temperature control. Maintaining a high and stable return temperature means a higher level of boiler efficiency, reduced tarring and increased life span of boiler.

**TECHNICAL DATA**

Pressure class: \_\_\_\_\_ PN 10  
 Temperature of medium: \_\_\_\_\_ max 100°C  
 \_\_\_\_\_ min 0°C  
 Max. differential pressure - Mixing: \_\_\_\_\_ 100 kPa (1,0 bar)  
 - Diverting: \_\_\_\_\_ 30 kPa (0,3 bar)  
 Leakage, A - AB: \_\_\_\_\_ Tight sealing  
 B - AB: \_\_\_\_\_ Tight sealing  
 Rangeability Kv/Kv<sup>min</sup>: \_\_\_\_\_ 100  
 Connections: \_\_\_\_\_ External thread (G), ISO 228/1

Material  
 Valve housing and other metal parts with fluid contact:  
 \_\_\_\_\_ dezincification resistant brass, DZR

PED 2014/68/EU, article 4.3

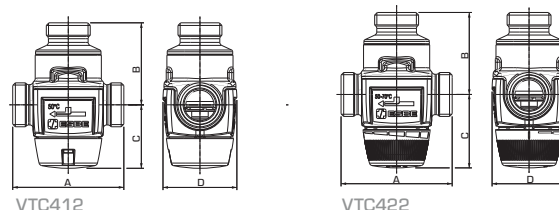

**VTC412** External thread

Art. No.	Reference	DN	Kvs	Connection	Opening Temperature **	A	B	C	D	Weight [kg]
51060100	VTC412	25	5,5	G 1"	50°C ± 4°C	84	62	48	56	0,69
51060200					55°C ± 4°C					
51060300					60°C ± 4°C					
51060400					65°C ± 4°C					
51060500					70°C ± 4°C					

**VTC422** External thread

Art. No.	Reference	DN	Kvs	Connection	Opening Temperature **	A	B	C	D	Weight [kg]
51060600	VTC422	25	4,5	G 1"	50 - 70°C ± 4°C	84	62	60	56	0,77

**FOR MORE VERSIONS .....WWW.ESBE.EU**



**ADDITIONAL GUIDANCE**

Accessories..... 108      Installation examples..... 111  
 Guide & Dimensioning..... 110      For further detailed information ..... www.esbe.eu

\*\* Temperature stability conditions are applicable when hot water is >10°C warmer than mixed temperature and cold water is >20°C colder than mixed temperature.

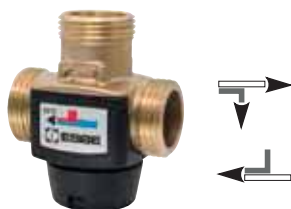

## LOAD VALVE

### Series VTC300

- **Accurate control of the return water temperature**
- **Easy installation. No need of adjustment valve**
- **Easy but normally not required maintenance**

The series VTC300 is a compact and accurate load valve used for solid fuel boilers up to 30 kW. The load valve makes sure that the boiler gets up to a high combustion temperature so as to ensure the lowest possible emissions. Above all, the valves make sure that the return temperature to the boiler is kept high and guaranteed over the entire combustion cycle which enables a higher level of boiler efficiency, reduced tarring and increased life span of the boiler.

#### TECHNICAL DATA

Pressure class: \_\_\_\_\_ PN 10  
 Temperature of medium: \_\_\_\_\_ max 100°C  
 \_\_\_\_\_ min 0°C  
 Max. differential pressure - Mixing: \_\_\_\_\_ 100 kPa (1,0 bar)  
 - Diverting: \_\_\_\_\_ 30 kPa (0,3 bar)  
 Leakrate A - AB: \_\_\_\_\_ Tight sealing  
 Leakrate B - AB: \_\_\_\_\_ max 3% of Kvs  
 Rangeability Kv/Kv<sup>min</sup>: \_\_\_\_\_ 100  
 Connections: \_\_\_\_\_ Internal thread (Rp), EN 10226-1  
 \_\_\_\_\_ External thread (G), ISO 228/1  
 Material  
 Valve housing and other metal parts with fluid contact:  
 \_\_\_\_\_ Brass DZR, CW 625N, resistant to dezincification  
 PED 2014/68/EU, article 4.3



VTC311



VTC312



VTC317



VTC318

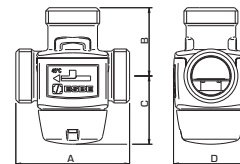

#### VTC311 Internal thread

Art. No.	Reference	DN	Kvs	Connection	Opening Temperature	A	B	C	D	Weight [kg]
51000100	VTC311	20	3,2	Rp 3/4"	45°C ± 2°C	70	42	42	46	0,53
51000200					55°C ± 2°C					
51000300					60°C ± 2°C					

#### VTC312 External thread

Art. No.	Reference	DN	Kvs	Connection	Opening Temperature	A	B	C	D	Weight [kg]
51000800	VTC312	15	2,8	G 3/4"	45°C ± 2°C	70	42	42	46	0,48
51000900					55°C ± 2°C					
51001000					60°C ± 2°C					
51001500	VTC312	20	3,2	G 1"	45°C ± 2°C	70	42	42	46	0,51
51001600					55°C ± 2°C					
51001700					60°C ± 2°C					

#### VTC317 Pump flange/External thread

Art. No.	Reference	DN	Kvs	Connection	Opening Temperature	A	B	C	D	Weight [kg]
51002200	VTC317	20	3,2	PF 1 1/2", G1"	45°C ± 2°C	75	42	42	57	0,57
51002300					55°C ± 2°C					
51002400					60°C ± 2°C					

#### VTC318 Rotating nut/External thread

Art. No.	Reference	DN	Kvs	Connection	Opening Temperature	A	B	C	D	Weight [kg]
51002900	VTC318	20	3,2	RN 1", G 1"	45°C ± 2°C	70	42	42	46	0,49
51003000					55°C ± 2°C					
51003100					60°C ± 2°C					



#### ADDITIONAL GUIDANCE

Accessories..... 108  
 Guide & Dimensioning..... 110

FOR MORE VERSIONS ..... [WWW.ESBE.EU](http://WWW.ESBE.EU)

Installation examples..... 111  
 For further detailed information ..... [www.esbe.eu](http://www.esbe.eu)



**LOAD VALVE SET**  
Series UTC300

- **Protect boilers up to 20 kW from too low return temperatures**
- **Efficiently loads accumulation tanks**

The ESBE series UTC300 is a combination of two thermic 3-way valves designed to protect the boiler from return temperatures that are too low. Maintaining a high and stable return temperature means a higher level of boiler efficiency, reduced tarring and increased life span of the boiler. The UTC300 is used in heating applications up to 20 kW where solid fuel boilers are used to feed storage tanks. The valves are installed in the return pipe to the boiler (in combination of two opening temperatures 45°C and 60°C, which increases the efficiency of loading buffer tank).

**TECHNICAL DATA**

Pressure class: \_\_\_\_\_ PN 10  
 Temperature of medium: \_\_\_\_\_ max. 100°C  
 \_\_\_\_\_ min. 0°C  
 Mixed temperature: \_\_\_\_\_ 60°C + 45°C  
 Max. differential pressure - Mixing: \_\_\_\_\_ 100 kPa (1,0 bar)  
 - Diverting: \_\_\_\_\_ 30 kPa (0,3 bar)  
 Leakrate A - AB: \_\_\_\_\_ Tight sealing  
 Leakrate B - AB: \_\_\_\_\_ max 3% of Kvs  
 Rangeability Kv/Kv<sup>min</sup>: \_\_\_\_\_ 100  
 Connections: \_\_\_\_\_ External thread (G), ISO 228/1

Material  
 Valve housing and other metal parts with fluid contact:  
 \_\_\_\_\_ Brass DZR, CW 625N, resistant to dezincification

Consists of:  
 Load valve VTC317, with opening temperatur: \_\_\_\_\_ 60°C  
 and  
 Premixing valve VTC318, with opening temperatur: \_\_\_\_\_ 45°C

PED 2014/68/EU, article 4.3

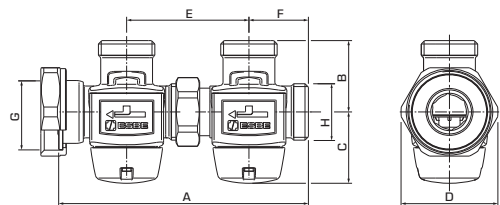

**UTC317** Pumpflange/External thread

Art. No.	Reference	DN	Kvs	Connection		A	B	C	D	E	F	Weight [kg]
				G	H							
51500100	UTC317	20	2,3	PF 1½"	G 1"	147	42	42	57	72	35	1,06



**DRAUGHT REGULATOR**  
Series ATA200

- **Temperature control of solid fuel boilers by adjusting air supply.**
- **No electrical wiring or complicated fitting is required.**
- **Easy but normally not required maintenance.**

The series ATA200 is a control device for regulating the temperature of solid fuel boilers. The thermostatic control head senses the temperature and through a lever and chain adjusts the position of the air vent, thereby regulating the combustion air supply to the boiler. The draught regulator is fully adjustable within the ranges of 35-95°C and 60-95°C. The draught regulator is connected directly to the boiler waterway through a threaded immersion pocket.

**TECHNICAL DATA**

Max. working temperature: \_\_\_\_\_ 100°C  
 Regulating range: \_\_\_\_\_ 35-95°C alt. 60-95°C  
 Lifting force: \_\_\_\_\_ 10 N  
 Lifting stroke: \_\_\_\_\_ 55 mm  
 Chain length: \_\_\_\_\_ 1,6 m  
 Connection: \_\_\_\_\_ External thread (G), ISO 228/1

Material  
 Metal parts: \_\_\_\_\_ Steel  
 Surface treatment: \_\_\_\_\_ Galvanized

PED 2014/68/EU, article 4.3

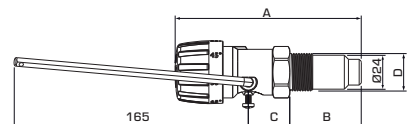

Art. No.	Reference	Lifting force [N]	Temp. range	Connection D	Dimension			Weight [kg]	Note
					A	B	C		
56001100	ATA212	10	35-95°	G ¾"	130	50	29	0,38	
56001500					155	75	29	0,41	
56001200					G 1"	130	50	29	0,40
56001300	ATA222	10	60-95°	G ¾"	130	50	29	0,38	



**ADDITIONAL GUIDANCE**

Guide & Dimensioning..... 110  
 Installation examples..... 111

For further detailed information ..... [www.esbe.eu](http://www.esbe.eu)



## FLUE GAS THERMOSTAT Series CTF200

- Switch temperature between 40-160°C
- On/off switch based on flue gas temperature

ESBE series CTF200 is an electro mechanical temperature controller/ resettable limiter which is intended for use in heat generator plants with multiple heat generators to change over from solid fuel to oil- or gas boilers.

Art. No.	Reference	Switch temp. range	Max. temp. probe
56020300	CTF271	40-160°C	750°C



## FLUE GAS THERMOSTAT Series CTF150

- On/off switch based on flue gas temperature
- Switch temperature between 20°C and 240°C

The series CTF150 is typically used for on/off control of circulation pumps and load units. The flue gas thermostat consists of a temperature probe connected to the switch unit. The switch is used to control the electrical supply to a circulation pump or a load unit with an integrated circulation pump. The temperature probe can be mounted on the outside of the flue gas pipe, or inside the pipe using the immersion pocket series CTF851. The switch unit is prepared for easy wall mounting.

Art. No.	Reference	Switch temp. range	Max. temp. probe
56020100	CTF151	20-240°C	500°C

Options series CTF151

Art. No.	Reference	Designation
56020200	CTF851	Immersion pocket



### ADDITIONAL GUIDANCE

Installation examples..... 111 For further detailed information ..... [www.esbe.eu](http://www.esbe.eu)

### TECHNICAL DATA

Ambient temperature - storage: \_\_\_\_\_ max. 70°C  
 - use: \_\_\_\_\_ -25°C to +75°C  
 Enclosure rating: \_\_\_\_\_ IP40 (EN 60529)  
 Switching capacity rating,  
 nominal voltage range: \_\_\_\_\_ 40...250 VAC  
 nominal current range: \_\_\_\_\_ 0,5...16(2,6)A  
 Hysteresis: \_\_\_\_\_ 11K ± 5,5  
 Immersion pocket: \_\_\_\_\_ Ø6,35 mm, length 150 mm  
 Weight: \_\_\_\_\_ 0,255 kg (without pocket)

Material  
 Case lid: \_\_\_\_\_ Polycarbonate (PC)  
 Housing: \_\_\_\_\_ reinforced Polyamid (PA)  
 Temperature probe: \_\_\_\_\_ Stainless steel  
 Immersion pocket: \_\_\_\_\_ Stainless steel

CE LVD 2006/95/EU - EMC 2004/108/EU

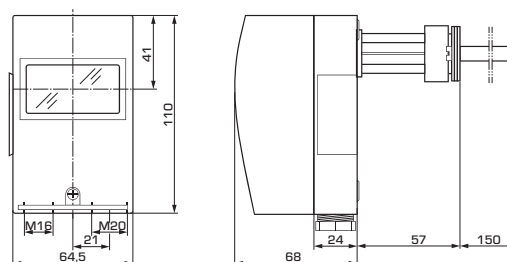

### TECHNICAL DATA

Ambient temperature - storage: \_\_\_\_\_ -30°C to +50°C  
 - use: \_\_\_\_\_ 0°C to +50°C  
 Enclosure rating: \_\_\_\_\_ IP54 (EN 60529)  
 Contact rating - N/C contact: \_\_\_\_\_ max. 16(2,5)A, 230 VAC  
 - N/O contact: \_\_\_\_\_ max. 6.3(2,5)A 230VAC  
 \_\_\_\_\_ min: 24V AC/DC, 100mA  
 Hysteresis: \_\_\_\_\_ 7% of the scale range  
 Temperature probe: \_\_\_\_\_ Ø6 mm x 96 mm  
 Line: \_\_\_\_\_ Ø1,5 mm x 1500 mm  
 Immersion pocket: \_\_\_\_\_ Ø8 mm x 0,75 mm, length 100 mm  
 Weight: \_\_\_\_\_ 0,2 kg

Material  
 Case lid: \_\_\_\_\_ Plastic ABS  
 Housing: \_\_\_\_\_ Plastic PA (inforced)  
 Temperature probe: \_\_\_\_\_ Stainless steel (CrNi, 1.4301)  
 Insulation: \_\_\_\_\_ Plastic PVC hose  
 Immersion pocket: \_\_\_\_\_ Stainless steel (CrNi, 1.4571)

CE EN 14597- LVD 2006/95/EU - EMC 2004/108/EU

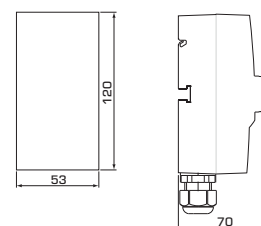



**THERMAL SAFETY VALVE**  
 Series VST200

- **Excellent safety for solid fuel boilers**
- **Two independant temperature sensors**
- **Metal hose coating of the capillary tubes**

The series VST200 prevents excess temperatures in solid fuel fired boilers. Heating capacities of up to a maximum of 100 kW are allowed for these systems. The thermal safety valve is a pressure-relieved single-seated valve that opens in case of escalating temperature. Install the thermal safety valve preferably in the cold water inlet of the safety heat exchanger.

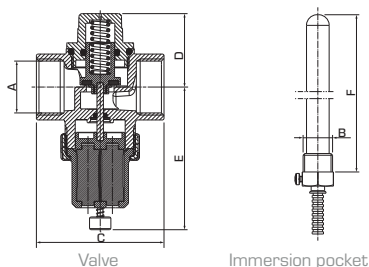

**TECHNICAL DATA**

Operating conditions  
 Pressure class: \_\_\_\_\_ PN 10  
 Temperature: \_\_\_\_\_ max. +125°C

Function  
 Opening temperature: \_\_\_\_\_ 95°C ±3°C  
 Boiler heat capacity: \_\_\_\_\_ max. 100 kW  
 Length of capillary tube: \_\_\_\_\_ 1,3m

Connection,  
 Valve: \_\_\_\_\_ Internal thread (G), ISO 228/1  
 Immersion pocket: \_\_\_\_\_ External thread (G), ISO 228/1

Material  
 Valve housing and other metal parts with fluid contact:  
 \_\_\_\_\_ Brass CW 617N - DIN 12164/5

Made for ESBE by IMT  
 Acc. to PED 97/23/EU, IV and standards EN 14597, VdTÜV-Merkblatt



Art. No.	Reference	Opening temperature [°C]	Relief capacity [m <sup>3</sup> /h] <sup>1)</sup>	DN	Connection						Weight [kg]
					A	B	C	D	E	F	
36020800	VST212	95 ± 3	1,35	20	G 3/4"	G 1/2"	60	34,5	67,1	157	0,64

ESBE ACCESSORIES  
**THERMOSTATS ETC.**



Options series LTC100, LTC200, VTC530, VTC510

Art. No.	Reference	Designation	Note
57020100	VTC951	Thermostat 50°C	
57020200		Thermostat 55°C	
57020300		Thermostat 60°C	
57020800		Thermostat 65°C	
57020400		Thermostat 70°C	
57020500		Thermostat 75°C	
57020600	VTC952	Thermometer, 3pcs	
57020700	VTC953	Insulation, ≥ DN32	

Options series VTC300, VTC400

Art. No.	Reference	Designation	Note
57000600	VTC931	Thermostat 42°C	
57000100		Thermostat 45°C	
57000700		Thermostat 50°C	
57000200		Thermostat 55°C	
57000300		Thermostat 60°C	
57000400		Thermostat 70°C	
57000500		Thermostat 80°C	



**ADDITIONAL GUIDANCE**

Installation examples..... 111 For further detailed information ..... [www.esbe.eu](http://www.esbe.eu)

Notes: 1) At 1 Bars pressure differential



# SOLID FUEL PRODUCTS DIMENSIONING

## SERIES LTC200

**Example:** Start with the heat output of the boiler (e.g. 40 kW) and move horizontally to the right in the diagram to the chosen  $\Delta t$  (recommended by boiler supplier), which is the temperature difference between the riser from the boiler and the return to the boiler (e.g.  $85^{\circ}\text{C} - 65^{\circ}\text{C} = 20^{\circ}\text{C}$ ).

Move vertically up to the curves representing load unit performance. Check that the pump curve overcomes the additional pressure drops in system components such as pipes, boiler and storage tank.

**LTC200** – available pressure of the pump

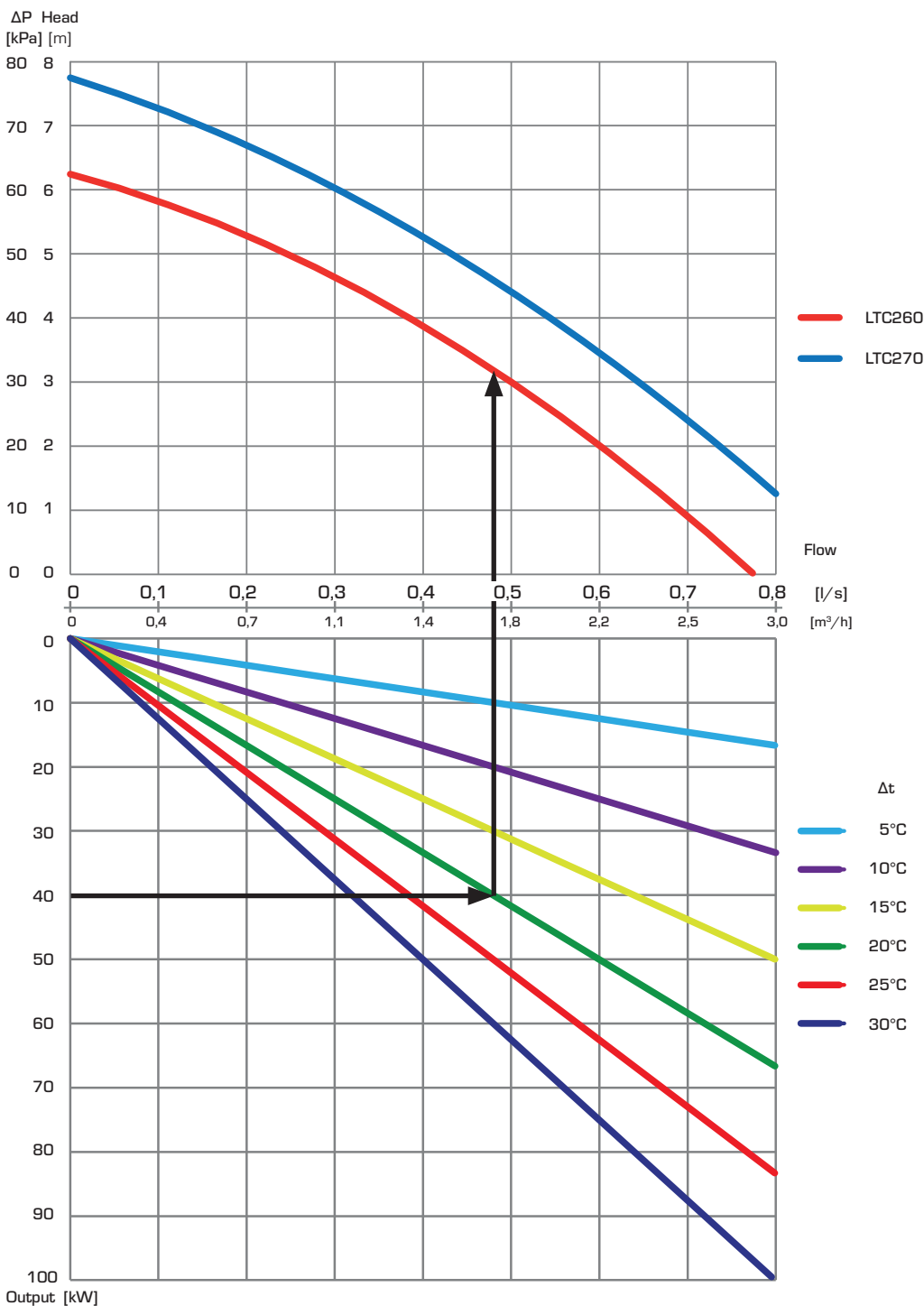

# SOLID FUEL PRODUCTS DIMENSIONING

## SERIES VTC300, VTC400, VTC500, UTC300

**Example:** Start with the heat demand in kW (e.g. 25 kW) and move vertically to the chosen  $\Delta t$ , which is the temperature difference between the riser from the boiler and the return to the boiler (e.g.  $90^{\circ}\text{C} - 70^{\circ}\text{C} = 20^{\circ}\text{C}$ ).

Move horizontally to the shaded field (pressure drop of 3-25 kPa) and select the smaller Kvs-value (e.g. 3,2). A load valve with suitable Kvs-value will be found in respective product description.

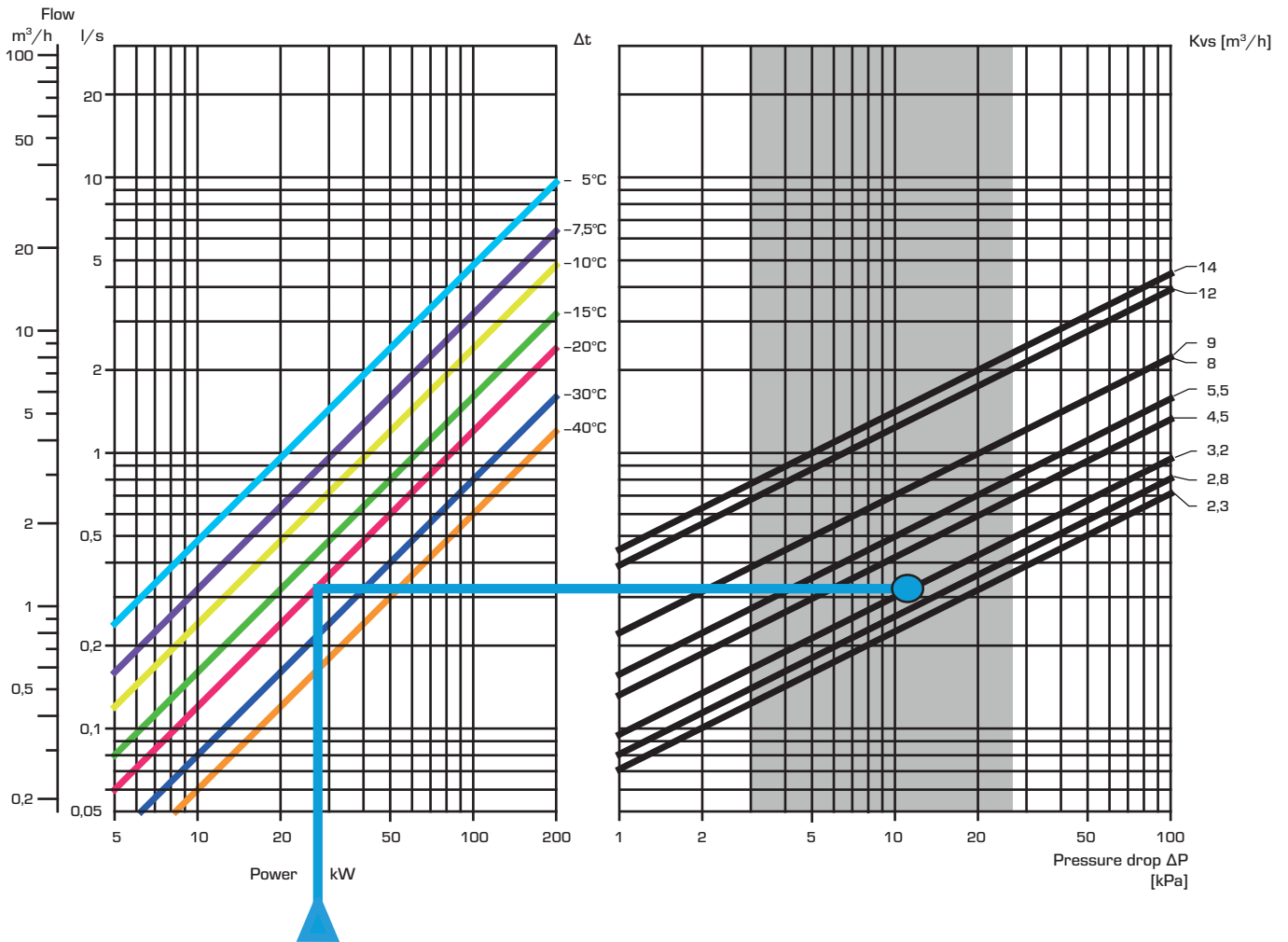

# SOLID FUEL PRODUCTS INSTALLATION EXAMPLES

## SERIES LTC200

1

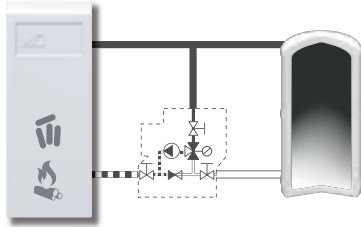

## SERIES VTC300/VTC400/VTC500

2

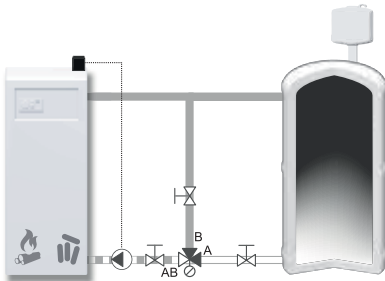

## SERIES VTC300/VTC400/VTC500

3

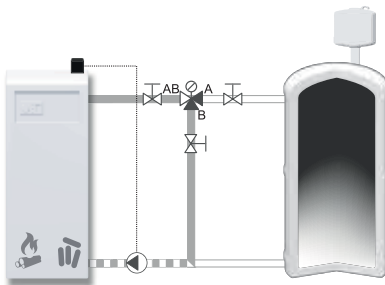

## SERIES VTC400

4

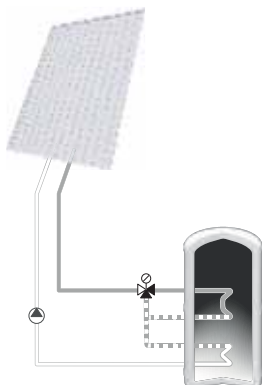

## SERIES UTC300

5

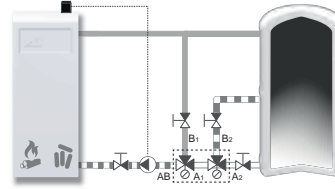

## SERIES ATA200

6

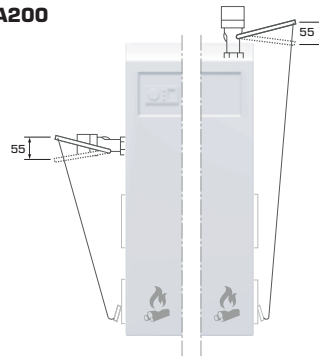

## SERIES CTF200

7

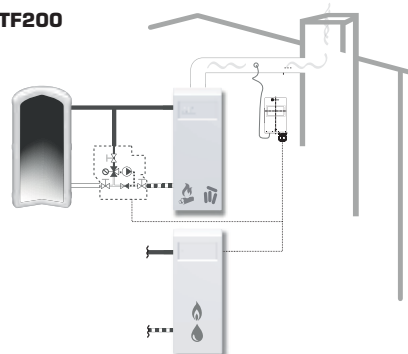

## SERIES CTF150

8

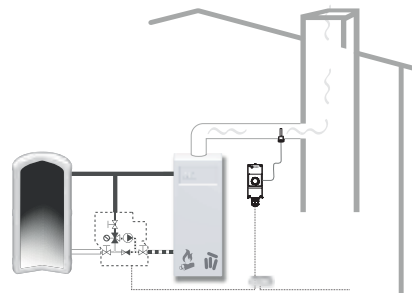

## SERIES VST200

9

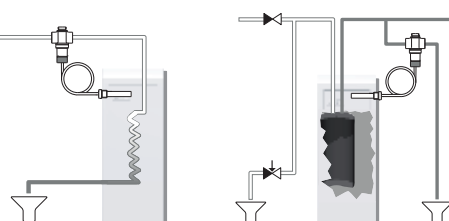

# DIVERTING VALVES

## QUICK SWITCHING. GREAT LONGEVITY. COMPACT DESIGN.

**ESBE diverting valves are designed for** rapidly switching the flow direction between two circuits. It opens up completely new fields of application.

**Legend**

2-P 2-point SPST = Single Pole Single Throw

 Spring return

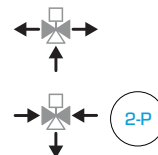

Internal thread, IP20  
without/detachable cableExternal thread, IP20  
without/detachable cableCompression fitting, IP20  
without/detachable cable

## MOTORIZED DIVERTING VALVE

### Series VZC, VZD

- **Fast change-over**
- **Anti-jamming program every 7th day**
- **0-percentage leakage**
- **Auxiliary switch available**

Series VZC, VZD is a range of compact diverting valves in brass for use in heat pumps, underfloor heating or HVAC applications. The main feature is the ability to rapidly change the flow direction between two circuits meaning a energy-efficient operation. The actuator series VZC has an Molex-type connector for quick cable connection to the control unit. The actuator series VZD is delivered with a fixed cable and has an enclosure rating of IP40. As an option series VZC, VZD is available with auxiliary switch

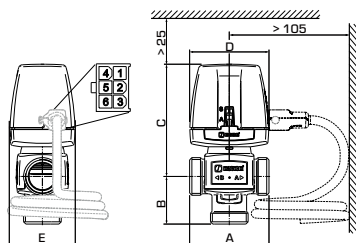

#### TECHNICAL DATA

Pressure class: \_\_\_\_\_ PN 6  
 Media temperature: \_\_\_\_\_ max. (continuously) +95°C  
 \_\_\_\_\_ max. (temporarily) +110°C  
 \_\_\_\_\_ min. +5°C  
 Max. differential pressure drop: \_\_\_\_\_ Diverting, 80 kPa (0,8 bar)  
 \_\_\_\_\_ Mixing, 50 kPa (0,5 bar)  
 Leakrate in % of flow: \_\_\_\_\_ 0  
 Connections: \_\_\_\_\_ Internal thread (Rp), EN 10226-1  
 \_\_\_\_\_ External thread (G), ISO 228/1  
 \_\_\_\_\_ Compression fitting (CPF), EN 1254-2  
 Ambient temperature: \_\_\_\_\_ max. +60°C  
 \_\_\_\_\_ min. 0°C  
 Power supply: \_\_\_\_\_ 230 ± 10% V AC, 50 Hz  
 Max. Power consumption \_\_\_\_\_ 15 VA  
 Power consumption idle: \_\_\_\_\_ 0,9 VA  
 Control signal: \_\_\_\_\_ 2-point SPST (Single Pole Single Throw)  
 Enclosure rating: \_\_\_\_\_ series VZC, IP20  
 \_\_\_\_\_ series VZD, IP40  
 Protection class: \_\_\_\_\_ II  
 Running time: \_\_\_\_\_ 3 s  
 Rating auxiliary switch: \_\_\_\_\_ 2(1)A 250 V AC  
 Cable length: \_\_\_\_\_ 1,6 m

Material  
 Valve body: \_\_\_\_\_ Dezincification resistant brass DZR  
 Plug and cover plate: \_\_\_\_\_ PPS  
 Spindle: \_\_\_\_\_ Stainless steel, SS 2346  
 O-rings: \_\_\_\_\_ EPDM

CE LVD 2014/35/EU - EMC 2014/30/EU - RoHS 2011/65/EU  
 PED 2014/68/EU, article 4.3

#### VZC161 Internal thread

Art. No.	Reference	DN	Kvs*	Connection	A	B	C	D	E	Cable version	Weight [kg]
43060200	VZC161	20	6,0	Rp 3/4"	70	42	99	70	58	1)	0,5

#### VZC162 External thread

Art. No.	Reference	DN	Kvs*	Connection	A	B	C	D	E	Cable version	Weight [kg]
43060600	VZC162	15	3,5	G 3/4"	70	42	99	70	58	1)	0,5
43060700		20	6,0	G 1"						2)	
43060800										1)	

#### VZC152 External thread

Art. No.	Reference	DN	Kvs*	Connection	A	B	C	D	E	Cable version	Weight [kg]
43061200	VZC152	20	6,0	G 1"	70	42	99	70	58	1), 4)	0,5

#### VZC263 Compression fitting

Art. No.	Reference	DN	Kvs*	Connection	A	B	C	D	E	Cable version	Weight [kg]
43061400	VZC263	20	4,5	CPF 22 mm	111	49	99	70	58	1)	0,6
43061600		25	6,0	CPF 28 mm	114	56	99	70	58	1)	0,7

SEE NEXT PAGE FOR MORE TABLES »



#### ADDITIONAL GUIDANCE

Accessories ..... 114  
 Installation examples ..... 120

For further detailed information ..... [www.esbe.eu](http://www.esbe.eu)

Notes: \* Kvs-value in diverting mode measured as m<sup>3</sup>/h at a pressure drop of 1 bar. Kvs-value in mixing mode 10% lower. 1) Detachable cable 2) Without cable 3) Fixed cable 4) With auxiliary switch



Internal thread, IP40 fixed cable



External thread, IP40 fixed cable



Compression fitting, IP40 fixed cable

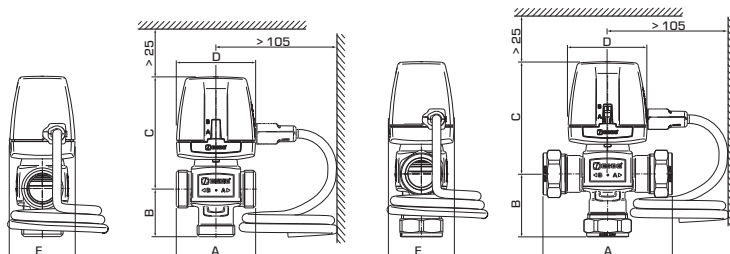
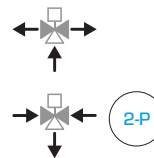

**VZD161** Internal thread

Art. No.	Reference	DN	Kvs*	Connection	A	B	C	D	E	Cable version	Weight [kg]
43080100	VZD161	20	6,0	Rp 3/4"	70	42	99	70	58	3)	0,5

**VZD162** External thread

Art. No.	Reference	DN	Kvs*	Connection	A	B	C	D	E	Cable version	Weight [kg]
43080300	VZD162	15	3,5	G 3/4"	70	42	99	70	58	3)	0,5
43080400		20	6,0	G 1"							

**VZD263** Compression fitting

Art. No.	Reference	DN	Kvs*	Connection	A	B	C	D	E	Cable version	Weight [kg]
43080700	VZD263	20	4,5	CPF 22 mm	111	49	99	70	58	3)	0,6
43080800		25	6,0	CPF 28 mm	114	56	99	70	58		0,7

ESBE ACCESSORIES  
**CABLES**



Options series VZC, VZD

Art. No.	Reference	Designation
46050300	ALZ801	Cable, loose version IP20, 3-wire
46050400		Cable, loose version IP20, 6-wire for use with auxiliary switch

**MOTORIZED DIVERTING VALVE**  
Series VRG232 + ARA645



Valve series VRG and actuator series ARA delivered as a set in an all-in-one package. For more information about the products, please see separate product pages.

**ADDITIONAL GUIDANCE**

Valve info .....45 Actuator info .....69

**VRG232 + ARA645**

Art. No.	Change-over/Diverting valve VRG232				Actuator ARA645				Note
	Pressure class	DN	Kvs	Connection	Control signal	Power supply	Running time 90° [s]	Torque [Nm]	
13023500	PN 10	25	10	G 1 1/4"	2-point SPST	230 V AC	30	6	
13023600		32	16	G 1 1/2"					
13023700		40	30	G 2"					

Notes: \* Kvs-value in diverting mode measured as m³/h at a pressure drop of 1 bar. Kvs-value in mixing mode 10% lower. 3) Fixed cable



## MOTORIZED DIVERTING VALVE Series MBA130

- Air bubble tight
- Auxiliary switch included
- Anti-condensation resistor to prevent condensation
- Flexible and easy to install

Series MBA130 is a range of 3-way motorized ball valves with actuator for use in heating and cooling system. The valve is air bubble tight according to EN12266-1. The MBA130 series is available in DN20-25 and comes with different type of connections to suit most needs. The actuator is assembled on the ball valve with a metallic spigot that allows to assembly/disassembly the actuator in a secure, simple and rapid way.



MBA132

MBA132



MBA135

MBA136

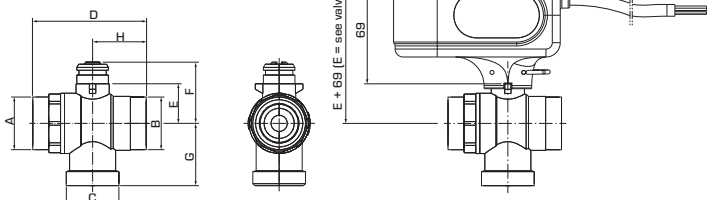

### TECHNICAL DATA

Valve  
 Pressure class: \_\_\_\_\_ PN 32  
 Media temperature: \_\_\_\_\_ max. +90°C  
 \_\_\_\_\_ min. 0°C  
 Torque (at nominal pressure): \_\_\_\_\_ < 4 Nm  
 Leakrate - EN12266-1: \_\_\_\_\_ internal leakage rate B, Air bubble tight  
 EN12266-1: \_\_\_\_\_ external leakage rate A, Air bubble tight  
 Working pressure: \_\_\_\_\_ 3,2 MPa (32 bar)  
 Connections: \_\_\_\_\_ Internal thread (G), ISO 228/1  
 \_\_\_\_\_ External thread (G), ISO 228/1  
 Media: \_\_\_\_\_ Heating water (in accordance with VDI2035)  
 \_\_\_\_\_ Water / Glycol mixtures, max. 50%  
 (above 20% admixture, the pumping data must be checked)

Material  
 Valve body, Body end, Union, Nut: \_\_\_\_\_ Brass CW 617N, Nickel plated  
 Seat, Washer: \_\_\_\_\_ PTFE  
 O-ring: \_\_\_\_\_ FPM  
 Ball, Shaft: \_\_\_\_\_ Brass CW 617N, Chrome plated  
 O-ring, shaft: \_\_\_\_\_ HNBR  
 Gasket: \_\_\_\_\_ Heat resistance fibre

Actuator  
 Ambient temperature: \_\_\_\_\_ max. +50°C  
 \_\_\_\_\_ min. 0°C  
 Enclosure rating: \_\_\_\_\_ IP44  
 Protection class: \_\_\_\_\_ II  
 Power supply: \_\_\_\_\_ 230 ± 10% VAC, 50 Hz  
 Control signal: \_\_\_\_\_ 2-point SPST  
 Power consumption - motor operation: \_\_\_\_\_ 3,5 W  
 - anti condensation resistor: \_\_\_\_\_ up to 5 W  
 Rating auxiliary switch: \_\_\_\_\_ 6(1) A 230 V AC  
 Running time 90°: \_\_\_\_\_ 40 seconds  
 Torque: \_\_\_\_\_ 10 Nm

CE LVD 2014/35/EU - EMC 2014/30/EU - RoHS 2011/65/EU  
 PED 2014/68/EU, article 4.3

### MBA132 External thread

Art. No.	Reference	DN	Kvs	Connection			D	E	F	G	H	Weight (kg)
				A	B	C						
43102500	MBA132	20	9,6	G 1"	G 1"	G 1"	72	25	39	39	34	0,76
43102600		25	11,3	G 1 1/4"	G 1 1/4"	G 1 1/4"	82	29	43	42	40	0,99

### MBA132 External thread with adapters

Art. No.	Reference	DN	Kvs	Connection			D	E	F	G	H	Weight (kg)
				A	B	C						
43102700	MBA132	20	9,6	G 3/4"	G 3/4"	G 3/4"	134	25	39	70	65	1,07
43102800		25	11,3	G 1"	G 1"	G 1"	149	29	43	76	73	1,46

### MBA135 Internal/External thread

Art. No.	Reference	DN	Kvs	Connection			D	E	F	G	H	Weight (kg)	Note
				A	B	C							
43102100	MBA135	20	9,6	G 3/4"	G 3/4"	G 3/4"	68	25	39	70	34	0,87	1)
43102200		25	11,3	G 1"	G 1"	G 1"	81	29	43	76	41	1,14	1)

### MBA136 Internal/External thread

Art. No.	Reference	DN	Kvs	Connection			D	E	F	G	H	Weight (kg)	Note
				A	B	C							
43102300	MBA136	20	9,6	G 3/4"	G 3/4"	G 3/4"	99	25	39	70	65	0,96	2)
43102400		25	11,3	G 1"	G 1"	G 1"	115	29	43	76	73	1,32	2)

Note 1) Connection A, B = Internal thread, Connection C = External thread 2) Connection A = Internal thread, Connection B, C = External thread





**MOTORIZED DIVERTING VALVE**  
 Series ZRS230

- Closing pressure up to 150 kPa
- Manual operation possible
- Fast running time
- Flow direction AB to B without power

Series ZRS230 is a range of 3-way diverting motorized zone valve with spring return actuator for use in heating and cooling system. The actuator is controlled by 2-point signal with spring return function and is recommended for diverting function, available for 230 V AC, 50/60 Hz power supply.

**TECHNICAL DATA**

Valve:  
 Pressure class: \_\_\_\_\_ PN 16  
 Media temperature: \_\_\_\_\_ max. +94°C  
 \_\_\_\_\_ min. +2°C  
 Media: \_\_\_\_\_ Water / Glycol mixtures, max. 50%.  
 (above 20% admixture, the pump data must be checked)  
 Working pressure: \_\_\_\_\_ 1,6 MPa (16 bar)  
 Max. differential pressure: \_\_\_\_\_ see table  
 Connections: \_\_\_\_\_ Internal thread (G), ISO 228/1 B

Material  
 Valve body: \_\_\_\_\_ Brass CW 614N  
 Ball: \_\_\_\_\_ NBR  
 O-rings: \_\_\_\_\_ EPDM

Actuator:  
 Ambient temperature: \_\_\_\_\_ max. +60°C  
 \_\_\_\_\_ min. 0°C  
 Enclosure rating: \_\_\_\_\_ IP44  
 Protection class: \_\_\_\_\_ I  
 Connection cable: \_\_\_\_\_ 1 meter  
 Power supply: \_\_\_\_\_ 230 V AC, 50/60 Hz  
 Control signal: \_\_\_\_\_ 2-point (2-wire spring return)  
 Power consumption: \_\_\_\_\_ 6 VA  
 Running time, opening: \_\_\_\_\_ 15 seconds  
 closing: \_\_\_\_\_ 5 seconds

CE LVD 2014/35/EU - EMC 2014/30/EU - RoHS 2011/65/EU  
 PED 2014/68/EU, article 4.3

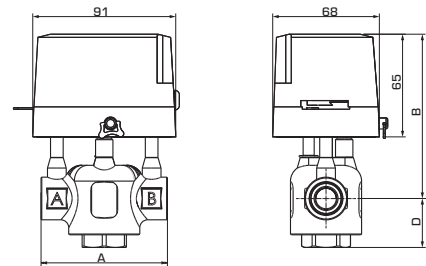

**ZRS234** Internal thread

Art. No.	Reference	DN	Kvs	Max. differential pressure [kPa]	Connection	A	B	D	Weight [kg]	Note
43123100	ZRS234	15	3,2	150	G 1/2"	80	103	29	1,02	
43123200		20	4,6	100	G 3/4"	89		32	1,07	
43123300		25	5,7		G 1"	93		37	1,16	
43123400		32	8,4	80	G 1 1/4"	105		110	45	1,58



**ADDITIONAL GUIDANCE**

Installation examples.....120

For further detailed information ..... [www.esbe.eu](http://www.esbe.eu)



## MOTORIZED ZONE VALVE

### Series MBA120

- High flow capabilities
- Air bubble tight
- Anti-condensation resistor to prevent condensation
- Flexible and easy to install

Series MBA120 is a range of 2-way motorized ball valves with actuator for use in heating and cooling system. The valve is air bubble tight according to EN12266-1. The MBA120 series is available in DN20-32 and comes with different type of connections to suit most needs. The actuator is assembled on the ball valve with a metallic spigot that allows to assembly/disassembly the actuator in a secure, simple and rapid way.

#### TECHNICAL DATA

Valve  
 Pressure class: \_\_\_\_\_ PN 32  
 Media temperature: \_\_\_\_\_ max. +90°C  
 \_\_\_\_\_ min. 0°C  
 Torque (at nominal pressure): \_\_\_\_\_ < 4 Nm  
 Leakrate - EN12266-1: \_\_\_\_\_ internal leakage rate A, Air bubble tight  
 EN12266-1: \_\_\_\_\_ external leakage rate A, Air bubble tight  
 Working pressure: \_\_\_\_\_ 3,2 MPa (32 bar)  
 Connections: \_\_\_\_\_ Internal thread (G), ISO 228/1  
 \_\_\_\_\_ External thread (G), ISO 228/1  
 Media: \_\_\_\_\_ Heating water (in accordance with VDI2035)  
 \_\_\_\_\_ Water / Glycol mixtures, max. 50%  
 (above 20% admixture, the pumping data must be checked)  
 Material  
 Valve body, Body end, Union, Nut: \_\_\_\_\_ Brass CW 617N, Nickel plated  
 Seat, Washer: \_\_\_\_\_ PTFE  
 O-ring: \_\_\_\_\_ FPM  
 Ball, Shaft: \_\_\_\_\_ Brass CW 617N, Chrome plated  
 O-ring, shaft: \_\_\_\_\_ HNBR  
 Gasket: \_\_\_\_\_ Heat resistance fibre  
 Actuator  
 Ambient temperature: \_\_\_\_\_ max. +50°C  
 \_\_\_\_\_ min. 0°C  
 Enclosure rating: \_\_\_\_\_ IP44  
 Protection class: \_\_\_\_\_ II  
 Power supply: \_\_\_\_\_ 230 ± 10% VAC, 50 Hz  
 Control signal: \_\_\_\_\_ 2-point SPST  
 Power consumption - motor operation: \_\_\_\_\_ 3,5 W  
 - anti condensation resistor: \_\_\_\_\_ up to 5 W  
 Rating auxiliary switch: 6(1) A 230 V AC  
 Running time 90°: \_\_\_\_\_ 40 seconds  
 Torque: \_\_\_\_\_ 10 Nm

CE LVD 2014/35/EU - EMC 2014/30/EU - RoHS 2011/65/EU  
 PED 2014/68/EU, article 4.3

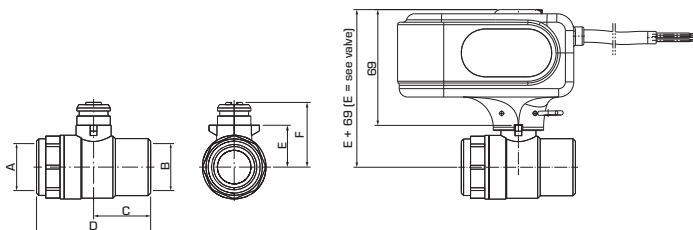

#### MBA122 External thread with adapters

Art. No.	Reference	DN	Kvs	Connection		C	D	E	F	Weight (kg)	Note
				A	B						
43100700	MBA122	15	20	G 1/2"	G 1/2"	58,5	118	21,5	35	0,73	
43100800		20	45	G 3/4"	G 3/4"	65	133,5	25	39	0,93	
43100900		25	60	G 1"	G 1"	73	149	29	43	1,24	
43101000		32	100	G 1 1/4"	G 1 1/4"	74	158	34	48	1,55	

#### MBA122 External thread

Art. No.	Reference	DN	Kvs	Connection		C	D	E	F	Weight (kg)	Note
				A	B						
43101100	MBA122	15	20	G 3/4"	G 3/4"	31	62	21,5	35	0,61	
43101200		20	45	G 1"	G 1"	34	72	25	38,5	0,72	
43101300		25	60	G 1 1/4"	G 1 1/4"	39,5	82	29	42,5	0,91	
43101400		32	100	G 1 1/2"	G 1 1/2"	36	86	34	47,5	1,10	

SEE NEXT PAGE FOR MORE TABLES »



#### ADDITIONAL GUIDANCE

Installation examples.....120 For further detailed information ..... www.esbe.eu



MBA121

MBA124

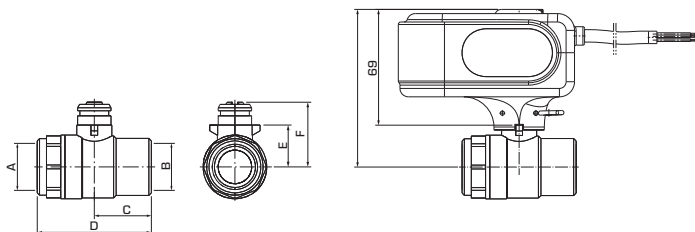

**MBA121** Internal thread

Art. No.	Reference	DN	Kvs	Connection		C	D	E	F	Weight (kg)	Note
				A	B						
43100100	MBA121	20	45	G 3/4"	G 3/4"	34	68	25	39	0,74	
43100200		25	60	G 1"	G 1"	41	82	29	43	0,93	
43100300		32	100	G 1 1/4"	G 1 1/4"	43	86	34	48	1,08	

**MBA124** Internal/External thread

Art. No.	Reference	DN	Kvs	Connection		C	D	E	F	Weight (kg)	Note
				A	B						
43100400	MBA124	20	45	G 3/4"	G 3/4"	65	99	25	39	0,83	1)
43100500		25	60	G 1"	G 1"	73	115	29	43	1,04	
43100600		32	100	G 1 1/4"	G 1 1/4"	75	119	34	48	1,28	



**MOTORIZED ZONE VALVE**  
Series ZRS220

- Closing pressure up to 200 kPa
- Manual operation possible
- Fast running time
- Flow direction is from A to B-port

The ESBE Series ZRS220 is a range of 2-way motorized zone valve with spring return actuator for use in heating and cooling system. The actuator is controlled by 2-point signal with spring return function and is recommended for on/off function, available for 230 VAC, 50/60 Hz power supply.

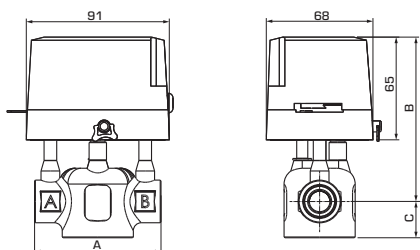

**TECHNICAL DATA**

Valve  
 Pressure class: \_\_\_\_\_ PN 16  
 Media temperature: \_\_\_\_\_ max. +94°C  
 \_\_\_\_\_ min. +2°C  
 Media: \_\_\_\_\_ Water / Glycol mixtures, max. 50%.  
 (above 20% admixture, the pump data must be checked)  
 Working pressure: \_\_\_\_\_ 1,6 MPa (16 bar)  
 Max. differential pressure: \_\_\_\_\_ see table  
 Connections: \_\_\_\_\_ Internal thread (G), ISO 228/1 B

Material  
 Valve body: \_\_\_\_\_ Brass CW 614N  
 Ball: \_\_\_\_\_ NBR  
 O-rings: \_\_\_\_\_ EPDM

Actuator  
 Ambient temperature: \_\_\_\_\_ max. +60°C  
 \_\_\_\_\_ min. 0°C  
 Enclosure rating: \_\_\_\_\_ IP44  
 Protection class: \_\_\_\_\_ I  
 Connection cable: \_\_\_\_\_ 1 meter  
 Power supply: \_\_\_\_\_ 230 V AC, 50/60 Hz  
 Control signal: \_\_\_\_\_ 2-point (2-wire spring return)  
 Power consumption: \_\_\_\_\_ 6 VA  
 Running time, opening: \_\_\_\_\_ 15 seconds  
 closing: \_\_\_\_\_ 5 seconds

CE LVD 2014/35/EU - EMC 2014/30/EU - RoHS 2011/65/EU  
 PED 2014/68/EU, article 4.3

**ZRS224** Internal thread

Art. No.	Reference	DN	Kvs	Max. differential pressure [kPa]	Connection	A	B	D	Weight (kg)	Note
43122100	ZRS224	15	3,2	200	G 1/2"	80	103	21	1,01	
43122200		20	4,6	150	G 3/4"	89			1,05	
43122300		25	5,7	100	G 1"	93	110	30	1,13	
43122400		32	10	80	G 1 1/4"	105			1,50	



**ADDITIONAL GUIDANCE**

Installation examples.....120

For further detailed information ..... [www.esbe.eu](http://www.esbe.eu)

Note 1) Connection A = Internal thread, Connection B = External thread



## THERMOSTATIC DIVERTING VALVE Series VTD300

- **Fast change-over**
- **Increased utilization of energy**
- **No need for electrical installation**

The series VTD300 are thermic valves used for diverting applications. When the incoming fluid temperature is below the nominal diverting temperature it is diverted to the B port, when the incoming fluid temperature is above the nominal diverting temperature it is diverted to the A port.

### TECHNICAL DATA

Pressure class: \_\_\_\_\_ PN 10  
 Change-over point accuracy: \_\_\_\_\_ ±1 °C  
 Diverting range shut off: \_\_\_\_\_ 45°C ±2°C  
 \_\_\_\_\_ 50°C, 60°C, 70°C ±3°C  
 Media temperature: \_\_\_\_\_ continuously max. 100°C  
 \_\_\_\_\_ temporarily max. 110°C  
 \_\_\_\_\_ min 0°C  
 Max. differential pressure: \_\_\_\_\_ 100 kPa (1,0 bar)  
 Leakrate AB - A, AB - B: \_\_\_\_\_ Tight sealing  
 Connections: \_\_\_\_\_ External thread (G), ISO 228/1  
 Media: \_\_\_\_\_ Heating water (in accordance with VDI2035)  
 \_\_\_\_\_ Water / Glycol mixtures, max. 50%  
 (above 20% admixture, the pumping data must be checked)

Material  
 Valve housing and other metal parts with fluid contact:  
 \_\_\_\_\_ Dezincification resistant brass DZR  
 PED 2014/68/EU, article 4.3

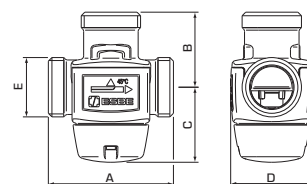

Art. No.	Reference	DN	Kvs	Connection E	Change-over point	A	B	C	D	Weight (kg)
31600100	VTD322	20	3,6	G 1"	45°C	70	42	42	46	0,45
31600200					50°C					
31600300					60°C					

FOR MORE VERSIONS ..... [WWW.ESBE.EU](http://WWW.ESBE.EU)



## THERMOSTATIC DIVERTING VALVE Series VTD500

- **Adjustable diverting temperature**
- **Efficient use of energy**
- **No power supply needed**
- **Fast change-over**
- **Easy to use**
- **Increases system performance**

The series VTD500 are thermostatic valves with an adjustable temperature setting used for diverting applications. The diverting temperature can be set in a range of 42-52°C. When the incoming fluid temperature is below the nominal diverting temperature, it is diverted to the A port. When the incoming fluid temperature is above the nominal diverting temperature, it is diverted to the B port.

### TECHNICAL DATA

Pressure class: \_\_\_\_\_ PN 10  
 Diverting range shut off: \_\_\_\_\_ 42-52°C ±3°C  
 Media temperature: \_\_\_\_\_ continuously max. 100°C  
 \_\_\_\_\_ temporarily max. 110°C  
 \_\_\_\_\_ min 0°C  
 Max. differential pressure: \_\_\_\_\_ 300 kPa (3 bar)  
 Leakrate, AB - A: \_\_\_\_\_ 0,5%  
 AB - B: \_\_\_\_\_ 2%  
 Connections: \_\_\_\_\_ External thread (G, R), ISO 228/1  
 Media: \_\_\_\_\_ Heating water (in accordance with VDI2035)  
 \_\_\_\_\_ Water / Glycol mixtures, max. 50%  
 (above 20% admixture, the pumping data must be checked)

Material  
 Valve housing and other metal parts with fluid contact:  
 \_\_\_\_\_ Dezincification resistant brass DZR  
 PED 2014/68/EU, article 4.3

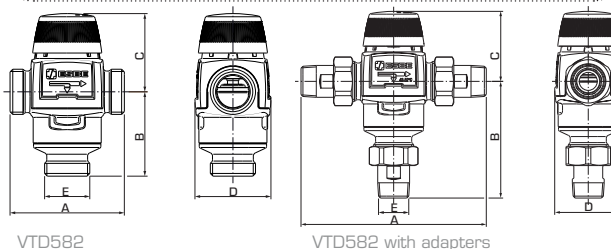

### VTD582 External thread

Art. No.	Reference	DN	Kvs	Connection E	Change-over point	A	B	C	D	Weight (kg)
31580100	VTD582	20	2,8	G 1"	42-52°C	84	62	60	56	0,86

### VTD582 External thread with adapters

Art. No.	Reference	DN	Kvs	Connection E	Change-over point	A	B	C	D	Weight (kg)
31580200	VTD582	20	2,8	R ¾"	42-52°C	154	97	60	56	1,26



### ADDITIONAL GUIDANCE

Installation examples.....120 For further detailed information ..... [www.esbe.eu](http://www.esbe.eu)

## DIVERTING VALVES INSTALLATION EXAMPLES

### SERIES VZC/VZD/MBA130/ZRS230

1

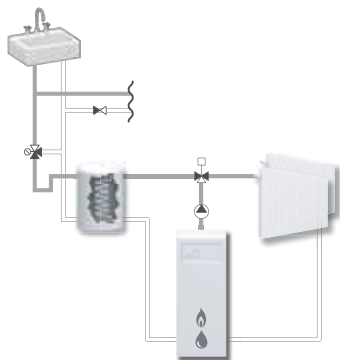

### SERIES VTD300

2

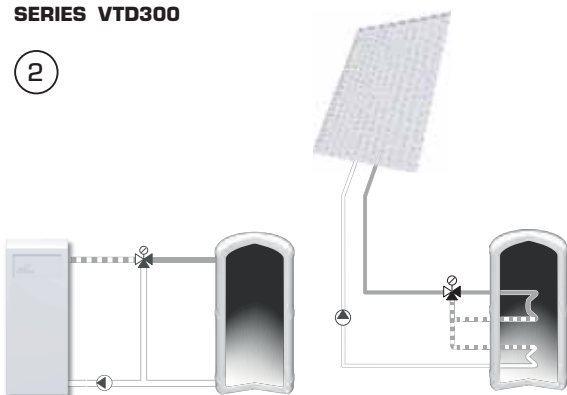

### SERIES VTD500

3

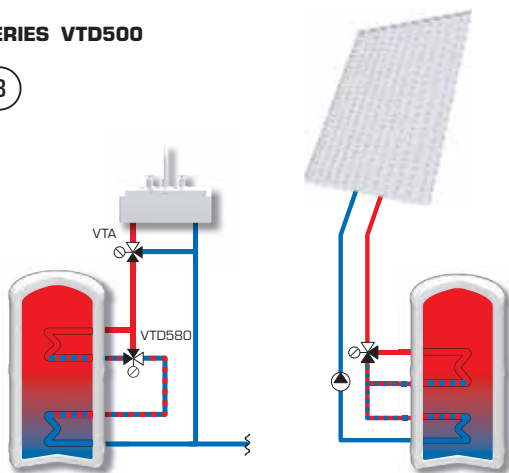

### SERIES MBA120/ZRS220

4

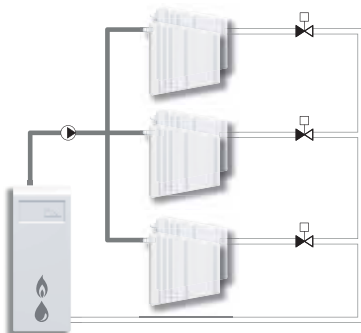

# THERMOSTATIC UNITS

## SAFETY IN AN ALL-IN-ONE-PACKAGE

**Next to our well-known thermostatic mixing valve** we have added features that in a compact way gains specific application solutions. Think safety but receive also a smart and quick way to solve a solar or tap water installation.



### Legend



Potable water, Anti-scald function



Solar heating, Anti-scald function



- From fall 2014 all ESBE products containing brass which are recommended for use in drinking water are manufactured out of dezincification resistant brass DZR which are according to the "Hygienic copper alloy composition list HCACL" this includes the 4MS-Composition List of accepted metallic materials and the German UBA List.





## CIRCULATION SET

Series VTRx00

- Hot water available instantly
- All in one, easy installation
- Anti-scald protection
- Insulation for minimized energy losses
- VTR500 for multifamily houses

The series VTR300 and VTR500 for hot water circulation installations. The Circulation Set offers instantly available hot water, scald protection and comfort in a compact and efficient way. Using only thermostatic components (non-electrical) the unit is completely independent and provides very easy installation, with connections and check valves included.

### TECHNICAL DATA

Pressure class: \_\_\_\_\_ PN 10  
 Working pressure: \_\_\_\_\_ 1,0 MPa (10 bar)  
 Differential pressure: \_\_\_\_\_ Mixing, max. 0,3 MPa (3 bar)  
 Media temperature: \_\_\_\_\_ max. 95°C  
 Temperature stability – VTR300: \_\_\_\_\_ ± 2°C\*  
 – VTR500: \_\_\_\_\_ ± 4°C\*\*  
 Connection: \_\_\_\_\_ External thread (R), EN 10226-1  
 Material  
 Valve housing and other metal parts with fluid contact:  
 \_\_\_\_\_ Dezincification resistant brass, DZR  
 Insulation: \_\_\_\_\_ EPP black 35g/l

PED 2014/68/EU, article 4.3



HCACL/4MS UBAList  
 KTW/WRAS/ACS

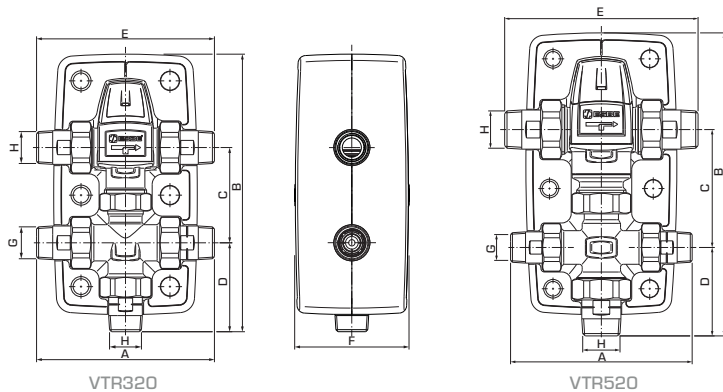

### VTR322 External thread

Art. No.	Reference	Temp. range	Kvs	Connection		A	B	C	D	E	F	Weight (kg)
				G	H							
31400100	VTR322	35-60°C	1,6	R ¾"	R ¾"	140	219	75	70	140	90	1,45
31400200		45-65°C										
31400300		50-75°C										

### VTR522 External thread

Art. No.	Reference	Temp. range	Kvs	Connection		A	B	C	D	E	F	Weight (kg)
				G	H							
31400400	VTR522	45-65°C	3,5	R ¾"	R 1"	154	257	100	75	164	100	2,2
31400500		50-75°C										

## ESBE ACCESSORIES

### PIPE IN PIPE SYSTEM

Art. No.	Reference	Connection	Note
31405010	VTR801	Rp 1"	suits VTR322, length ~1,5 m/ PE-Xc 8 mm



### ADDITIONAL GUIDANCE

Guide & Dimensioning.....138  
 Installation examples.....125

For further detailed information ..... [www.esbe.eu](http://www.esbe.eu)

Note \* Valid at unchanged hot/cold water pressure, minimum flow rate 4 l/min. Minimum temperature difference between hot water inlet and mixed water outlet 10°C. \*\* Valid at unchanged hot/cold water pressure, minimum flow rate 9 l/min. Minimum temperature difference between hot water inlet and mixed water outlet 10°C.





## VALVE MANIFOLD Series VMB400

- All in one, easy installation
- Anti-scald and anti-legionella protection
- Accuracy of regulation

The series VMB400 is a compact valve combination for hot water storage. The valve combination has non return and shut-down device incorporated and connections for safety valve, vacuum valve etc. The incoming hot-water is regulated within a temperature range of 35 to 60°C by a thermostatic mixing valves.

### TECHNICAL DATA

Pressure class: \_\_\_\_\_ PN 10  
 Differential pressure: \_\_\_\_\_ Mixing, max. 0,3 MPa (3 bar)  
 Media temperature: \_\_\_\_\_ max. 95°C  
 Temperature stability: \_\_\_\_\_ ±2°C\*  
 Temperature range: \_\_\_\_\_ 35-60°C  
 Connection: \_\_\_\_\_ Internal thread (G), ISO 228/1  
 \_\_\_\_\_ Compression fitting (CPF), EN 1254-2

Material  
 Valve housing and other metal parts with fluid contact:  
 \_\_\_\_\_ Dezincification resistant brass, DZR

PED 2014/68/EU, article 4.3  HCACL/4MS UBAList  
 KTW/WRAS/ACS

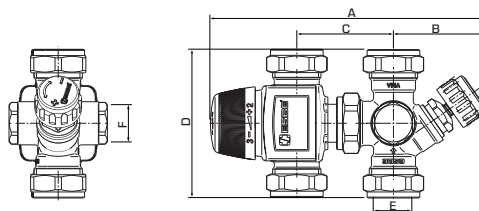

Art. No.	Reference	DN	Kvs	Safety Valve		Connection		A	B	C	D	Weight (kg)
				[MPa]	[bar]	E	F					
31502000	VMB423	15	1,1	-	-	CPF 15 mm	G ½"	165	53	≈ 55	86	0,78
31502600				1,0	10							0,93
31502100	VMB423	20	1,6	-	-	CPF 22 mm	G ½"	165	53	52-60	86	0,86
31502200				0,6	6							1,01
31502300				0,7	7							1,01
31502400				0,9	9							1,01
31502500				1,0	10							1,01



## SOLAR KIT Series VMD300

- Optimized energy efficiency
- Anti-scald protection
- Accuracy of regulation
- Easy installation

The series VMD300 with adjustable set temperature for dual source domestic hot water. The diverting temperature on the Solar Kit is fully adjustable between 42 and 52 degrees to optimize the energy efficiency in favor of Solar energy, the renewable and free energy.

### TECHNICAL DATA

Pressure class: \_\_\_\_\_ PN 10  
 Max. flow from collector: \_\_\_\_\_ 0,7 l/s (42 l/min)  
 Temperature of water from collector: \_\_\_\_\_ max 95°C  
 \_\_\_\_\_ min 0°C  
 Temperature from additional heat source: \_\_\_\_\_ max. 95°C  
 Temperature range, diverting valve: \_\_\_\_\_ 42-52°C  
 Temperature range, mixing valve: \_\_\_\_\_ 35-60°C  
 Temperature stability of outgoing water: \_\_\_\_\_ ±2°C\*  
 Connection: \_\_\_\_\_ External thread (R), EN 10226-1

Material  
 Valve housing and other metal parts with fluid contact:  
 \_\_\_\_\_ Dezincification resistant brass, DZR  
 Insulation: \_\_\_\_\_ EPP black 35g/l

PED 2014/68/EU, article 4.3  HCACL/4MS UBAList  
 KTW/WRAS/ACS

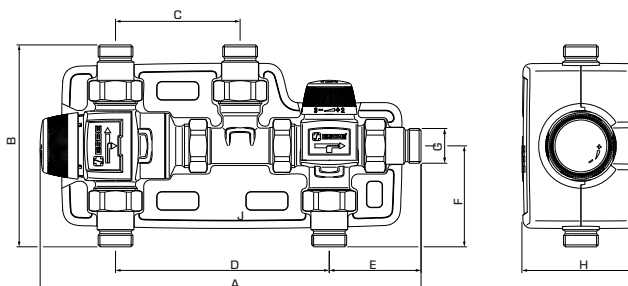

### ADDITIONAL GUIDANCE

Installation examples.....125  
 For further detailed information ..... www.esbe.eu

Art. No.	Reference	Change-over point	Kvs	Connection G	Dimension							Weight (kg)
					A	B	C	D	E	F	H	
31525000	VMD322	42-52°C	1,4	R ¾"	max 293	154	95	163	70	77	90	2,21

Note \* Valid at unchanged hot/cold water pressure, minimum flow rate 4 l/min. Minimum temperature difference between hot water inlet and mixed water outlet 10°C.



## SOLAR KIT

Series VMC300, VMC500

- **Optimized energy usage**
- **Anti-scald protection**
- **Accuracy of regulation**
- **Easy installation**

The series VMC300/VMC500 for dual source domestic hot water. The Solar Kit offers optimized energy usage, scald protection and comfort in a compact and efficient way. Using only thermostatic components (non-electrical) the unit is completely independent and provides very easy installation.

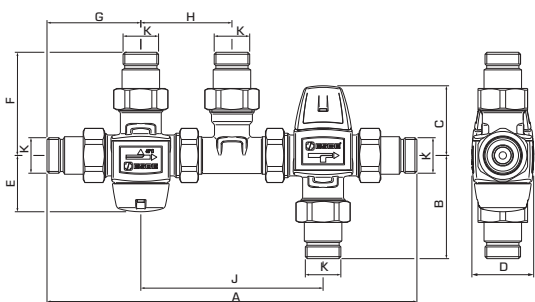

### TECHNICAL DATA

Pressure class: \_\_\_\_\_ PN 10  
 Max. flow from collector - VMC300: \_\_\_\_\_ 0,7 l/s [42 l/min]  
 VMC500: \_\_\_\_\_ 1,0 l/s [60 l/min]  
 Temperature of water from collector: \_\_\_\_\_ max 95°C  
 \_\_\_\_\_ min 0°C  
 Temperature from additional heat source: \_\_\_\_\_ max. 95°C  
 Change-over point, accuracy: \_\_\_\_\_ ±1°C  
 Diverting range shut off: \_\_\_\_\_ 45°C ±2°C  
 \_\_\_\_\_ 50°C, 60°C ±3°C  
 Temperature range, mixing valve - VMC300: \_\_\_\_\_ 35 - 60°C  
 VMC500: \_\_\_\_\_ 45 - 65°C  
 Temperature stability of outgoing water - VMC300: \_\_\_\_\_ ±2°C\*  
 VMC500: \_\_\_\_\_ ±4°C\*\*  
 Connection: \_\_\_\_\_ External thread (G), ISO 228/1  
 \_\_\_\_\_ External thread (R), EN 10226-1

Material  
 Valve housing and other metal parts with fluid contact:  
 \_\_\_\_\_ Dezincification resistant brass, DZR

PED 2014/68/EU, article 4.3  HCACL/ 4MS UBAList  
 KTW/WRAS/ACS

### VMC322 External thread

Art. No.	Reference	Change-over point	Kvs	Connction K	Dimension								Weight (kg)	Note	
					A	B	C	D	E	F	G	H			J
31521000	VMC322	45°C	1,5	G 1"	206	42	52	46	42	42	35	68	136	1,22	
31521100		50°C													

### VMC322 External thread with adapters

Art. No.	Reference	Change-over point	Kvs	Connction K	Dimension								Weight (kg)	Note	
					A	B	C	D	E	F	G	H			J
31521300	VMC322	45°C	1,4	R ¾"	276	77	52	46	42	77	79	68	136	1,86	1]
31521400		50°C													

### VMC522 External thread

Art. No.	Reference	Change-over point	Kvs	Connction K	Dimension								Weight (kg)	Note	
					A	B	C	D	E	F	G	H			J
31523000	VMC522	45°C	2,5	G 1"	220	62	60	56	42	42	35	68	143	1,50	
31523100		50°C													

### VMC522 External thread with adapters

Art. No.	Reference	Change-over point	Kvs	Connction K	Dimension								Weight (kg)	Note	
					A	B	C	D	E	F	G	H			J
31523300	VMC522	45°C	2,3	R ¾"	290	97	60	56	42	77	70	68	143	2,14	1]
31523400		50°C													

## ESBE ACCESSORIES THERMOSTATS

Options series VMC300

Art. No.	Reference	Designation
57000600	VTC931	Thermostat 42°C



FOR MORE VERSIONS ..... [WWW.ESBE.EU](http://WWW.ESBE.EU)



### ADDITIONAL GUIDANCE

Accessories.....136  
 Guide & Dimensioning.....138  
 Installation examples.....125  
 For further detailed information ..... [www.esbe.eu](http://www.esbe.eu)

Note \* Valid at unchanged hot/cold water pressure, minimum flow rate 4 l/min. Minimum temperature difference between hot water inlet and mixed water outlet 10°C. \*\* Valid at unchanged hot/cold water pressure, minimum flow rate 9 l/min. Minimum temperature difference between hot water inlet and mixed water outlet 10°C. 1] Two check valves for both hot and cold water are included

# THERMOSTATIC UNITS INSTALLATION EXAMPLES

## SERIES VMD300



## SERIES VTR300/VTR500

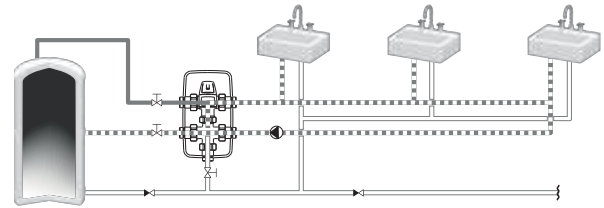

## SERIES VMC300/VMC500



## SERIES VMC300/VMC500

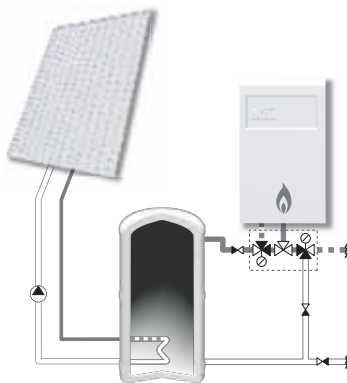

## SERIES VMB400

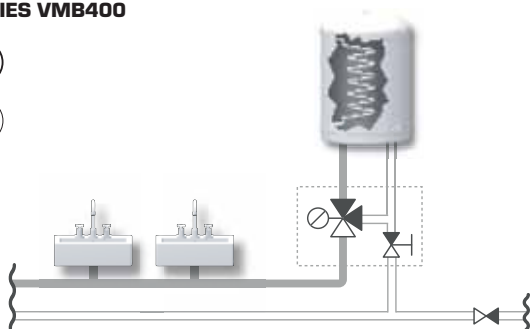

# THERMOSTATIC MIXING VALVES PROVIDES SAFETY

**Our series of thermostatic mixing valves** has made heroes of installation engineers throughout Europe. The basic requirement for ensuring a tap water system is safe to use involves the prevention of two significant factors: legionella bacteria and scalding.



**Legend**

- Potable water, Anti-scald function
- Solar heating, Anti-scald function
- Potable water, No anti-scald function
- Under floor heating or wall heating, Anti-scald function



• From fall 2014 all ESBE products containing brass which are recommended for use in drinking water are manufactured out of dezincification resistant brass DZR which are according to the "Hygienic copper alloy composition list HCACL" this includes the 4MS-Composition List of accepted metallic materials and the German UBA List.



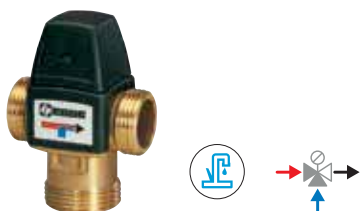

## THERMOSTATIC MIXING VALVE

Basic series VTA320, VTA520

- **Anti-scald and anti-legionella protection**
- **Accuracy of regulation**
- **Suitable for HWC (hot water circulation)**

The series VTA320/VTA520 for domestic hot water distribution, anti-scalded tempering in line applications and where further temperature control devices have been installed at the water taps. These series of valves are also suitable for domestic hot water installations equipped with HWC (hot water circulation).

### TECHNICAL DATA

Pressure class: \_\_\_\_\_ PN 10  
 Working pressure: \_\_\_\_\_ 1,0 MPa (10 bar)  
 Differential pressure: \_\_\_\_\_ Mixing, max. 0,3 MPa (3 bar)  
 Media temperature, VTA320, VTA520: \_\_\_\_\_ max. 95°C  
 VTA520: \_\_\_\_\_ temporarily max. 100°C  
 Temperature stability, VTA320: \_\_\_\_\_ ±2°C\*  
 VTA520: \_\_\_\_\_ ±4°C\*\*  
 Connection: \_\_\_\_\_ Internal thread (Rp), EN 10226-1  
 \_\_\_\_\_ External thread (G), ISO 228/1  
 \_\_\_\_\_ External thread (R), EN 10226-1  
 \_\_\_\_\_ Compression fitting (CPF), EN 1254-2

### Material

Valve housing and other metal parts with fluid contact:  
 \_\_\_\_\_ Dezincification resistant brass, DZR

PED 2014/68/EU, article 4.3  HCACL/4MS UBAList  
 KTW/WRAS/ACS

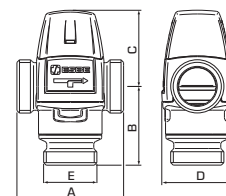

**VTA321** Internal thread

Art. No.	Reference	Temp. range	Kvs	Connection E	Dimension				Weight (kg)	Note
					A	B	C	D		
31100300	VTA321	20-43°C	1,5	Rp 1/2"	70	42	52	46	0,45	
31100700			1,6	Rp 3/4"					0,48	
31100400	VTA321	35-60°C	1,5	Rp 1/2"	70	42	52	46	0,45	
31100800			1,6	Rp 3/4"					0,48	

**VTA322, VTA522** External thread

Art. No.	Reference	Temp. range	Kvs	Connection E	Dimension				Weight (kg)	Note
					A	B	C	D		
31102800	VTA322	20-43°C	1,2	G 1/2"	70	42	52	46	0,41	
31100500			1,5	G 3/4"					0,45	
31100900			1,6	G 1"					0,48	
31620100	VTA522		3,2	G 1"	84	62	60	56	0,86	
31620400			3,5	G 1 1/4"					0,95	
31102900	VTA322	35-60°C	1,2	G 1/2"	70	42	52	46	0,41	
31100600			1,5	G 3/4"					0,45	
31101000			1,6	G 1"					0,48	
31620200	VTA522	45-65°C	3,2	G 1"	84	62	60	56	0,86	
31620500			3,5	G 1 1/4"					0,95	
31103200	VTA322	30-70°C	1,6	G 1"	70	42	52	46	0,55	
31620300	VTA522	50-75°C	3,2	G 1"	84	62	60	56	0,86	
31620600			3,5	G 1 1/4"					0,95	

**VTA323** Compression fitting

Art. No.	Reference	Temp. range	Kvs	Connection E	Dimension				Weight (kg)	Note
					A	B	C	D		
31102600	VTA323	20-43°C	1,2	CPF 15 mm	86	50	52	46	0,49	1)
31100100			1,5	CPF 22 mm					0,57	
31102700		35-60°C	1,2	CPF 15 mm	86	50	52	46	0,49	1)
31103900			1,5	CPF 18 mm					0,66	
31100200			1,5	CPF 22 mm					0,57	1)

SEE NEXT PAGE FOR MORE TABLES »

Note \* Valid at unchanged hot/cold water pressure, minimum flow rate 4 l/min. Minimum temperature difference between hot water inlet and mixed water outlet 10°C. \*\* Valid at unchanged hot/cold water pressure, minimum flow rate 9 l/min. Minimum temperature difference between hot water inlet and mixed water outlet 10°C. 1) A non-return valve for the cold water is included

# THERMOSTATIC MIXING VALVES

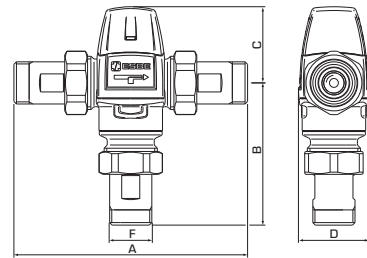

**VTA522** External thread with adapters

Art. No.	Reference	Temp. range	Kvs	Connection F	Dimension				Weight (kg)	Note
					A	B	C	D		
31620700	VTA522	20-43°C	3,0	R ¾"	154	97	60	56	1,22	2)
31621000			3,4	R 1"	164	102			1,59	
31620800		45-65°C	3,0	R ¾"	154	97	60	56	1,22	
31621100			3,4	R 1"	164	102			1,59	
31620900		50-75°C	3,0	R ¾"	154	97	60	56	1,22	
31621200			3,4	R 1"	164	102			1,59	

**VTA523** Compression fitting with adapters

Art. No.	Reference	Temp. range	Kvs	Connection F	Dimension				Weight (kg)	Note
					A	B	C	D		
31621600	VTA523	20-43°C	3,4	CPF 28 mm	164	102	60	56	1,59	2)
31621400		45-65°C	3,0	CPF 22 mm	154	97	60	56	1,22	
31621700			3,4	CPF 28 mm	164	102	60	56	1,59	

FOR MORE VERSIONS ..... [WWW.ESBE.EU](http://WWW.ESBE.EU)



## THERMOSTATIC MIXING VALVE

Basic series VTA350, VTA550

- **Anti-scald and anti-legionella protection**
- **Accuracy of regulation**
- **Suitable for HWC (hot water circulation)**

The series VTA350/VTA550 for domestic hot water distribution, anti-scalded tempering in line applications and where further temperature control devices have been installed at the water taps. These series of valves are also suitable for domestic hot water installations equipped with HWC (hot water circulation).

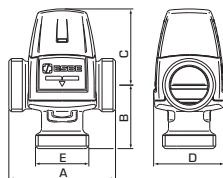

**VTA351** Internal thread

Art. No.	Reference	Temp. range	Kvs	Connection E	Dimension				Weight (kg)	Note
					A	B	C	D		
31104900	VTA351	35-60°C	1,5	Rp ¾"	70	42	52	46	0,48	

SEE NEXT PAGE FOR MORE TABLES »

### TECHNICAL DATA

Pressure class: \_\_\_\_\_ PN 10  
 Working pressure: \_\_\_\_\_ 1,0 MPa (10 bar)  
 Differential pressure: \_\_\_\_\_ Mixing, max. 0,3 MPa (3 bar)  
 Media temperature, VTA350, VTA550: \_\_\_\_\_ max. 95°C  
 VTA550: \_\_\_\_\_ temporarily max. 100°C  
 Temperature stability, VTA350: \_\_\_\_\_ ±2°C\*  
 VTA550: \_\_\_\_\_ ±4°C\*\*  
 Connection: \_\_\_\_\_ Internal thread (Rp), EN 10226-1  
 \_\_\_\_\_ External thread (G), ISO 228/1  
 \_\_\_\_\_ External thread (R), EN 10226-1  
 \_\_\_\_\_ Compression fitting (CPF), EN 1254-2  
 Material  
 Valve housing and other metal parts with fluid contact:  
 \_\_\_\_\_ Dezincification resistant brass, DZR  
 PED 2014/68/EU, article 4.3  HCACL/4MS UBAList  
 KTW/WRAS/ACS



### ADDITIONAL GUIDANCE

Accessories.....136 Installation examples..... 139-142  
 Guide & Dimensioning.....137-138 For further detailed information ..... [www.esbe.eu](http://www.esbe.eu)

Note \* Valid at unchanged hot/cold water pressure, minimum flow rate 4 l/min. Minimum temperature difference between hot water inlet and mixed water outlet 10°C. \*\* Valid at unchanged hot/cold water pressure, minimum flow rate 9 l/min. Minimum temperature difference between hot water inlet and mixed water outlet 10°C. Note 2) Two check valves for both hot and cold water are included

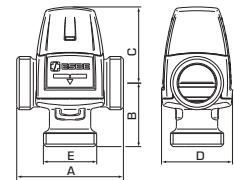

**VTA352, VTA552** External thread

Art. No.	Reference	Temp. range	Kvs	Connection E	Dimension				Weight (kg)	Note
					A	B	C	D		
31660100	VTA552	20-43°C	3,2	G 1"	84	50	60	56	0,78	
31660400			3,5	G 1 1/4"					0,87	
31105000	VTA352	35-60°C	1,5	G 3/4"	70	42	52	46	0,45	
31105100			1,6	G 1"					0,48	
31660200	VTA552	45-65°C	3,2	G 1"	84	50	60	56	0,78	
31660500			3,5	G 1 1/4"					0,87	
31660300	VTA552	50-75°C	3,2	G 1"	84	50	60	56	0,78	
31660600			3,5	G 1 1/4"					0,87	

**VTA352** External thread with integrated check valves

Art. No.	Reference	Temp. range	Kvs	Connection E	Dimension				Weight (kg)	Note
					A	B	C	D		
31106100	VTA352	35-60°C	1,5	G 1"	70	42	52	46	0,48	

**VTA353** Compression fitting

Art. No.	Reference	Temp. range	Kvs	Connection E	Dimension				Weight (kg)	Note
					A	B	C	D		
31105200	VTA353	35-60°C	1,5	CPF 22 mm	70	42	52	46	0,57	



VTA552

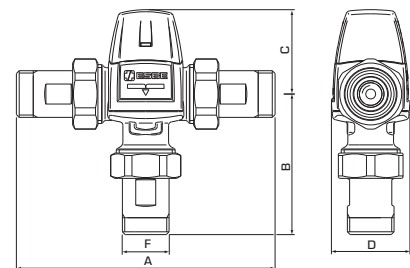

**VTA552** External thread with adapters

Art. No.	Reference	Temp. range	Kvs	Connection F	Dimension				Weight (kg)	Note
					A	B	C	D		
31660700	VTA552	20-43°C	3,0	R 3/4"	154	85	60	56	1,14	1)
31661000			3,4	R 1"	164	90			1,51	
31660800		45-65°C	3,0	R 3/4"	154	85	60	56	1,14	
31661100			3,4	R 1"	164	90			1,51	
31660900		50-75°C	3,0	R 3/4"	154	85	60	56	1,14	
31661200			3,4	R 1"	164	90			1,51	

FOR MORE VERSIONS ..... [WWW.ESBE.EU](http://WWW.ESBE.EU)



**ADDITIONAL GUIDANCE**

Accessories..... 136  
 Guide & Dimensioning..... 137-138

Installation examples..... 139-142  
 For further detailed information ..... [www.esbe.eu](http://www.esbe.eu)

Note 1) Two check valves for both hot and cold water are included



# THERMOSTATIC MIXING VALVES



## THERMOSTATIC MIXING VALVE

Premium series VTA330, VTA530

- Excellent accuracy of regulation
- Anti-scald and anti-legionella protection
- Quick reaction time
- Performing under varying pressure conditions

Series VTA330 is primarily designed to provide a highly accurate temperature regulation in point-of-use positions for domestic hot water, at taps or showers where no further temperature-control fittings have been installed. Series VTA530 is primarily designed to provide an accurate in-line temperature regulation of the domestic hot water in high flow applications, according to standards EN15092 or EN1111/NF079, where further temperature control fittings have been installed at taps or showers.

### TECHNICAL DATA

Pressure class: \_\_\_\_\_ PN 10  
 Working pressure: \_\_\_\_\_ 1.0 MPa (10 bar)  
 Differential pressure: \_\_\_\_\_ Mixing, max. 0,3 MPa (3 bar)  
 Media temperature, VTA330, VTA530: \_\_\_\_\_ max. 95°C  
 VTA530: \_\_\_\_\_ temporarily max. 100°C  
 Temperature stability, VTA330: \_\_\_\_\_ ±1°C\*  
 VTA530: \_\_\_\_\_ ±2°C\*\*  
 Connection: \_\_\_\_\_ External thread (G), ISO 228/1  
 \_\_\_\_\_ External thread (R), EN 10226-1  
 \_\_\_\_\_ Compression fitting (CPF), EN 1254-2  
 Material  
 Valve housing and other metal parts with fluid contact: \_\_\_\_\_  
 \_\_\_\_\_ Dezincification resistant brass, DZR  
 Surface treatment: \_\_\_\_\_ Nickel-plated  
 PED 2014/68/EU, article 4.3  HCACL/4MS UBAList  
 KTW/WRAS/ACS

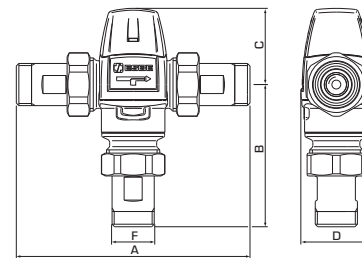
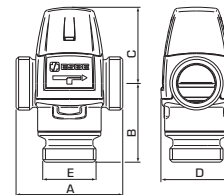

### VTA332, VTA532 External thread

Art. No.	Reference	Temp. range	Kvs	Connection E	Dimension				Weight (kg)	Note
					A	B	C	D		
31150200	VTA332	32-49°C	1,2	G ¾"	70	54	52	46	0,52	
31641000	VTA532	35-50°C	2,3	G 1"	84	62	60	56	0,86	2)
31641100			2,5	G 1 ¼"					0,95	
31150700	VTA332	35-60°C	1,2	G ¾"	70	54	52	46	0,52	
31150900			1,3	G 1"					0,55	
31640100	VTA532	45-65°C	2,3	G 1"	84	62	60	56	0,86	3)
31640200			2,5	G 1 ¼"					0,95	

### VTA333 Compression fitting

Art. No.	Reference	Temp. range	Kvs	Connection E	Dimension				Weight (kg)	Note
					A	B	C	D		
31150300	VTA333	35-60°C	1,2	CPF 22 mm	86	62	52	46	0,64	4)
31152100				CPF 15/22 mm					0,69	

### VTA532 External thread with adapters

Art. No.	Reference	Temp. range	Kvs	Connection F	Dimension				Weight (kg)	Note
					A	B	C	D		
31641200	VTA532	35-50°C	2,2	R ¾"	154	85	60	56	1,22	1), 2)
31641300			2,5	R 1"					164	
31640300		45-65°C	2,2	R ¾"	154	85	60	56	1,22	
31640400			2,5	R 1"					164	

### VTA533 Compression fitting with adapters

Art. No.	Reference	Temp. range	Kvs	Connection F	Dimension				Weight (kg)	Note
					A	B	C	D		
31641500	VTA533	35-50°C	2,5	CPF 28 mm	204	122	60	56	1,90	1), 2)
31640600		45-65°C								1), 3)

Note \* Valid at unchanged hot/cold water pressure, minimum flow rate 4 l/min. Minimum temperature difference between hot water inlet and mixed water outlet 10°C. \*\* Valid at unchanged hot/cold water pressure, minimum flow rate 9 l/min. Minimum temperature difference between hot water inlet and mixed water outlet 10°C. 1) Two check valves for both hot and cold water are included. 2) According to standard EN 1111 + NF079 (France). 3) According to standard EN 15092. 4) A non-return valve for the cold water is included.

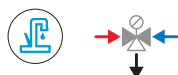

## THERMOSTATIC MIXING VALVE

### Premium series VTA360, VTA560

- **Excellent accuracy of regulation**
- **Anti-scald and anti-legionella protection**
- **Quick reaction time**
- **Performing under varying pressure conditions**

Series VTA360 is primarily designed to provide a highly accurate temperature regulation in point-of-use positions for domestic hot water, at taps or showers where no further temperature-control fittings have been installed. Series VTA560 is primarily designed to provide an accurate in-line temperature regulation of the domestic hot water in high flow applications, according to standards EN15092 or EN1111/NF079, where further temperature control fittings have been installed at taps or showers.

#### TECHNICAL DATA

Pressure class: \_\_\_\_\_ PN 10  
 Working pressure: \_\_\_\_\_ 1,0 MPa (10 bar)  
 Differential pressure: \_\_\_\_\_ Mixing, max. 0,3 MPa (3 bar)  
 Media temperature, VTA360, VTA560: \_\_\_\_\_ max. 95°C  
 VTA560: \_\_\_\_\_ temporarily max. 100°C  
 Temperature stability, VTA360: \_\_\_\_\_ ±1°C\*  
 VTA560: \_\_\_\_\_ ±2°C\*\*  
 Connection: \_\_\_\_\_ External thread (G), ISO 228/1  
 \_\_\_\_\_ External thread (R), EN 10226-1  
 \_\_\_\_\_ Compression fitting (CPF), EN 1254-2  
 Material  
 Valve housing and other metal parts with fluid contact: \_\_\_\_\_  
 \_\_\_\_\_ Dezincification resistant brass, DZR  
 Surface treatment: \_\_\_\_\_ Nickel-plated  
 PED 2014/68/EU, article 4.3  HCACL/4MS UBAList  
 KTW/WRAS/ACS



VTA362  
VTA562



VTA363

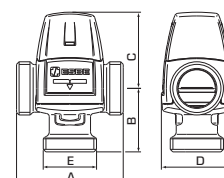

#### VTA362, VTA562 External thread

Art. No.	Reference	Temp. range	Kvs	Connection E	Dimension				Weight (kg)	Note
					A	B	C	D		
31151400	VTA362	32-49°C	1,2	G 3/4"	70	42	52	46	0,45	
31681000	VTA562	35-50°C	2,3	G 1"	84	50	60	56	0,78	2)
31681100			2,5	G 1 1/4"					0,87	
31151100	VTA362	35-60°C	1,2	G 3/4"	70	42	52	46	0,45	
31151200			1,3	G 1"					0,48	
31680100	VTA562	45-65°C	2,3	G 1"	84	50	60	56	0,78	3)
31680200			2,5	G 1 1/4"					0,87	

#### VTA363 Compression fitting

Art. No.	Reference	Temp. range	Kvs	Connection E	Dimension				Weight (kg)	Note
					A	B	C	D		
31151000	VTA363	35-60°C	1,2	CPF 22 mm	86	50	52	46	0,57	4)



VTA562

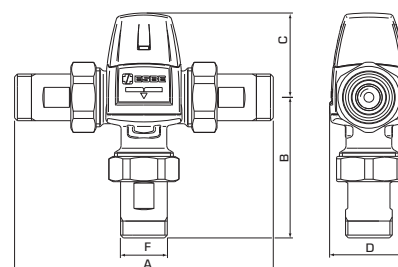

#### VTA562 External thread with adapters

Art. No.	Reference	Temp. range	Kvs	Connection F	Dimension				Weight (kg)	Note
					A	B	C	D		
31681200	VTA562	35-50°C	2,2	R 3/4"	154	85	60	56	1,14	1), 2)
31681300			2,5	R 1"	164	90			1,51	
31680300		45-65°C	2,2	R 3/4"	154	85	60	56	1,14	1), 3)
31680400			2,5	R 1"	164	90			1,51	



#### ADDITIONAL GUIDANCE

Accessories.....136  
 Guide & Dimensioning.....137-138

Installation examples.....139-142  
 For further detailed information ..... [www.esbe.eu](http://www.esbe.eu)

Note \* Valid at unchanged hot/cold water pressure, minimum flow rate 4 l/min. Minimum temperature difference between hot water inlet and mixed water outlet 10°C. \*\* Valid at unchanged hot/cold water pressure, minimum flow rate 9 l/min. Minimum temperature difference between hot water inlet and mixed water outlet 10°C. 1) Two check valves for both hot and cold water are included. 2) According to standard EN 1111 + NF079 (France). 3) According to standard EN 15092. 4) A non-return valve for the cold water is included.

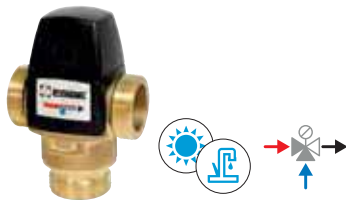

## THERMOSTATIC MIXING VALVE

Solar series VTS520

- High temperature resilience
- Anti-scald and anti-legionella protection
- Accuracy of regulation
- Suitable for HWC (hot water circulation)

The series VTS520 for domestic hot water distribution connected to solar heating systems, where the high water temperatures require extra durable components. VTS520 has asymmetrical flow pattern. These series of valves are also suitable for domestic hot water installations equipped with HWC (hot water circulation).

### TECHNICAL DATA

Pressure class: \_\_\_\_\_ PN 10  
 Working pressure: \_\_\_\_\_ 1,0 MPa (10 bar)  
 Differential pressure: \_\_\_\_\_ Mixing, max. 0,3 MPa (3 bar)  
 Media temperature: \_\_\_\_\_ continuously max. 110°C  
 \_\_\_\_\_ temporarily max. 120°C  
 Temperature stability: \_\_\_\_\_ ±4°C\*  
 Connection: \_\_\_\_\_ External thread (G), ISO 228/1  
 \_\_\_\_\_ External thread (R), EN 10226-1

Material  
 Valve housing and other metal parts with fluid contact:  
 \_\_\_\_\_ Dezincification resistant brass, DZR

PED 2014/68/EU, article 4.3  HCACL/4MS UBAList  
 KTW/WRAS/ACS



VTS522

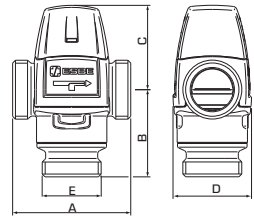

**VTS522** External thread

Art. No.	Reference	Temp. range	Kvs	Connection E	Dimension				Weight [kg]	Note
					A	B	C	D		
31720100	VTS522	45-65°C	3,2	G 1"	84	62	60	56	0,86	
31720300			3,5	G 1 1/4"					0,95	
31720200		50-75°C	3,2	G 1"	84	62	60	56	0,86	
31720400			3,5	G 1 1/4"					0,95	

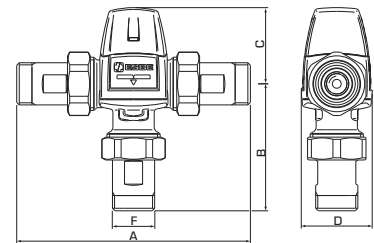

**VTS522** External thread with adapters

Art. No.	Reference	Temp. range	Kvs	Connection F	Dimension				Weight [kg]	Note
					A	B	C	D		
31720500	VTS522	45-65°C	3,0	R 3/4"	154	97	60	56	1,22	1)

**FOR MORE VERSIONS .....WWW.ESBE.EU**



### ADDITIONAL GUIDANCE

Accessories.....136 Installation examples..... 139-142  
 Guide & Dimensioning.....137-138 For further detailed information ..... www.esbe.eu

Note \* Valid at unchanged hot/cold water pressure, minimum flow rate 9 l/min. Minimum temperature difference between hot water inlet and mixed water outlet 10°C. 1) Two check valves for both hot and cold water are included.



## THERMOSTATIC MIXING VALVE

### Solar series VTS550

- **High temperature resilience**
- **Anti-scald and anti-legionella protection**
- **Accuracy of regulation**
- **Suitable for HWC (hot water circulation)**

The series VTS550 for domestic hot water distribution connected to solar heating systems, where the high water temperatures require extra durable components. VTS550 has symmetrical flow pattern. These series of valves are also suitable for domestic hot water installations equipped with HWC (hot water circulation).

#### TECHNICAL DATA

Pressure class: \_\_\_\_\_ PN 10  
 Working pressure: \_\_\_\_\_ 1,0 MPa (10 bar)  
 Differential pressure: \_\_\_\_\_ Mixing, max. 0,3 MPa (3 bar)  
 Media temperature: \_\_\_\_\_ continuously max. 110°C  
 \_\_\_\_\_ temporarily max. 120°C  
 Temperature stability: \_\_\_\_\_ ±4°C\*  
 Connection: \_\_\_\_\_ External thread (G), ISO 228/1  
 \_\_\_\_\_ External thread (R), EN 10226-1  
 \_\_\_\_\_ Compression fitting (CPF), EN 1254-2

#### Material

Valve housing and other metal parts with fluid contact:  
 \_\_\_\_\_ Dezincification resistant brass, DZR

PED 2014/68/EU, article 4.3



HCACL/4MS UBAList  
 KTW/WRAS/ACS



VTS552

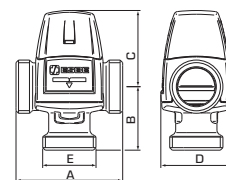

**VTS552** External thread

Art. No.	Reference	Temp. range	Kvs	Connection E	Dimension				Weight [kg]	Note
					A	B	C	D		
31740100	VTS552	45-65°C	3,2	G 1"	84	50	60	56	0,78	
31740300			3,5	G 1 1/4"					0,87	
31740200		50-75°C	3,2	G 1"	84	50	60	56	0,78	
31740400			3,5	G 1 1/4"					0,87	



VTS552

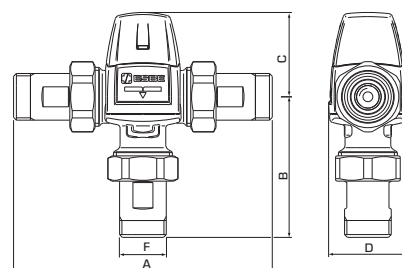

**VTS552** External thread with adapters

Art. No.	Reference	Temp. range	Kvs	Connection F	Dimension				Weight [kg]	Note
					A	B	C	D		
31740500	VTS552	45-65°C	3,0	R 3/4"	154	85	60	56	1,14	
31740700			3,4	R 1"					1,51	
31740600		50-75°C	3,0	R 3/4"	154	85	60	56	1,14	

**FOR MORE VERSIONS ..... WWW.ESBE.EU**



#### ADDITIONAL GUIDANCE

Accessories.....136 Installation examples..... 139-142  
 Guide & Dimensioning.....137-138 For further detailed information ..... www.esbe.eu

Note \* Valid at unchanged hot/cold water pressure, minimum flow rate 9 l/min. Minimum temperature difference between hot water inlet and mixed water outlet 10°C.



## THERMOSTATIC MIXING VALVE

Basic series VTA370, VTA570

- High flow capacity
- Protection against excess temperatures

The series VTA370 and VTA570 are the number one choice for heating and cooling applications. The valves provide a scald safe function, which is important in order to protect e.g. under floor heating pipes and also the floor itself from to uncontrolled rise of temperature.

### TECHNICAL DATA

Pressure class: \_\_\_\_\_ PN 10  
 Working pressure: \_\_\_\_\_ 1,0 MPa (10 bar)  
 Differential pressure, mixing, VTA570: \_\_\_\_\_ max. 0,3 MPa (3 bar)  
 VTA370: \_\_\_\_\_ max. 0,1 MPa (1 bar)  
 Max. media temperature,  
 Temp. range 10–30°C: \_\_\_\_\_ 65°C  
 Temp. range 20–55, 30–70°C: \_\_\_\_\_ continuously 95°C  
 \_\_\_\_\_ temporarily 100°C  
 Min. media temperature: \_\_\_\_\_ 0°C  
 Temperature stability,  
 Temp. range 10–30°C: \_\_\_\_\_ ±2°C\*  
 Temp. range 20–55, 30–70°C: \_\_\_\_\_ ±3°C\*\*  
 Connection: \_\_\_\_\_ External thread (G), ISO 228/1  
 Media: \_\_\_\_\_ Heating water (in accordance with VDI2035)  
 \_\_\_\_\_ Water / Glycol mixtures, max. 50%\*\*  
 (above 20% admixture, the pumping data must be checked)

### Material

Valve housing and other metal parts with fluid contact:  
 \_\_\_\_\_ Dezincification resistant brass, DZR

PED 2014/68/EU, article 4.3

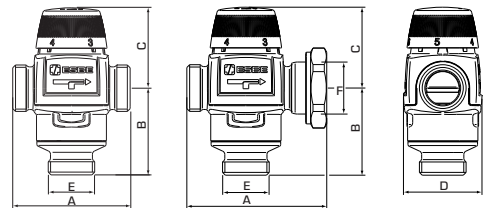

### VTA372, VTA572 External thread

Art. No.	Reference	Temp. range	Kvs	Connection E	Dimension				Weight [kg]	Note
					A	B	C	D		
31700100	VTA572	10 - 30°C	4,5	G 1"	84	62	60	56	0,86	
31700400			4,8	G 1¼"					0,95	
31200100	VTA372	20 - 55°C	3,4	G 1"	70	42	52	46	0,44	
31702100	VTA572	20 - 55°C	4,5	G 1"	84	62	60	56	0,86	
31702200			4,8	G 1¼"					0,95	
31200400	VTA372	30 - 70°C	3,4	G 1"	70	42	52	46	0,48	
31702500	VTA572	30 - 70°C	4,5	G 1"	80	62	60	56	0,86	
31702600			4,8	G 1¼"					0,95	

### VTA377, VTA577 Pump flange and External thread

Art. No.	Reference	Temp. range	Kvs	Connection		Dimension				Weight [kg]	Note
				E	F	A	B	C	D		
31200200	VTA377	20 - 55°C	3,4	G 1"	PF 1½"	86	42	52	57	0,58	
31702300	VTA577	20 - 55°C	4,5	G 1"	PF 1½"	100	62	60	57	0,99	

### VTA378, VTA578 Rotating nut and External thread

Art. No.	Reference	Temp. range	Kvs	Connection		Dimension				Weight [kg]	Note
				E	F	A	B	C	D		
31200300	VTA378	20 - 55°C	3,4	G 1"	RN 1"	78	42	52	56	0,48	
31702400	VTA578	20 - 55°C	4,5	G 1"	RN 1"	93	62	60	56	0,91	



### ADDITIONAL GUIDANCE

Accessories.....136 Installation examples..... 139–142  
 Guide & Dimensioning.....137–138 For further detailed information ..... www.esbe.eu

Note \* Valid at unchanged hot/cold water pressure, minimum flow rate 4 l/min. Minimum temperature difference between hot water inlet and mixed water outlet 10°C. \*\* Valid at unchanged hot/cold water pressure, minimum flow rate 9 l/min. Minimum temperature difference between hot water inlet and mixed water outlet 10°C.



## THERMOSTATIC MIXING VALVE

### Series VTA310

- Domestic hot water regulation
- Asymmetrical flow pattern

The series VTA310 is designed for temperature control in domestic hot water installations without any requirements for a scald safe function. This series of valves is not suitable for domestic hot water installations equipped with HWC.

#### TECHNICAL DATA

Pressure class: \_\_\_\_\_ PN 10  
 Differential pressure: \_\_\_\_\_ Mixing, max. 0,3 MPa (3 bar)  
 Media temperature: \_\_\_\_\_ max. 95°C  
 Temperature stability: \_\_\_\_\_ ±2°C\*  
 Connection: \_\_\_\_\_ External thread (G), ISO 228/1  
 \_\_\_\_\_ Compression fitting (CPF), EN 1254-2

Material  
 Valve housing and other metal parts with fluid contact:  
 \_\_\_\_\_ Dezincification resistant brass, DZR

PED 2014/68/EU, article 4.3  HCACL/4MS UBAList  
 KTW/WRAS/ACS

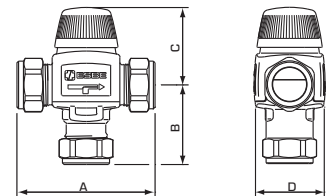

#### VTA312 External thread

Art. No.	Reference	Temp. range	Kvs	Connection	Dimension				Weight [kg]	Note
					A	B	C	D		
31050200	VTA312	35-60°C	1,2	G 1/2"	70	42	52	46	0,41	

#### VTA313 Compression fitting

Art. No.	Reference	Temp. range	Kvs	Connection	Dimension				Weight [kg]	Note
					A	B	C	D		
31050100	VTA313	35-60°C	1,2	CPF 15 mm	86	50	52	46	0,49	1)
31050400			1,5	CPF 22 mm					0,57	
31050500		30-70°C	1,5	CPF 22 mm					0,62	



#### ADDITIONAL GUIDANCE

Guide & Dimensioning.....137-138  
 Installation examples..... 139-142

For further detailed information ..... [www.esbe.eu](http://www.esbe.eu)

Note \* Valid at unchanged hot/cold water pressure, minimum flow rate 4 l/min. Minimum temperature difference between hot water inlet and mixed water outlet 10°C. 1) A non-return valve for the cold water is included.

# THERMOSTATIC MIXING VALVES



KCD300  
Compression fitting

## CONNECTION KIT Series KCD300

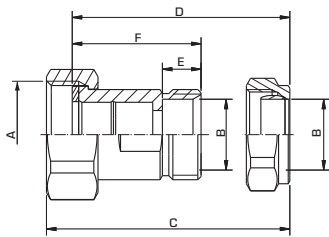

### TECHNICAL DATA

Pressure class: \_\_\_\_\_ PN10  
 Media temperature: \_\_\_\_\_ max. +120°C  
 \_\_\_\_\_ min. -20°C  
 Connection - nipple design: \_\_\_\_\_ acc. to EN 1254-2  
 \_\_\_\_\_ Internal thread (G), ISO 228/1  
 \_\_\_\_\_ Compression fitting (CPF), EN 1254-2

Material  
 Nut: \_\_\_\_\_ Brass CW 614N  
 Connection piece: \_\_\_\_\_ Dezincification resistant brass, DZR\*  
 Gasket: \_\_\_\_\_ Klingersil C-4400  
 Compression fitting nut: \_\_\_\_\_ Brass CW 614N  
 Compression ring: \_\_\_\_\_ Dezincification resistant brass, DZR\*

\* Suitable for drinking water applications

### KCD313 Compression fitting

Art. No.	Reference	Valve thread	Connection	Dimension				Weight [kg]	Note
				C	D	E	F		
36552900	KCD313	G 1"	CPF 22 mm	54	48	12	40	0,56	1)



KTD200  
External thread



KTD300  
External thread

## CONNECTION KIT Series KTD200, KTD300

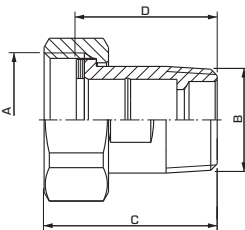

### TECHNICAL DATA

Pressure class: \_\_\_\_\_ PN10  
 Media temperature: \_\_\_\_\_ max. +120°C  
 \_\_\_\_\_ min. -20°C  
 Connection - nipple design: \_\_\_\_\_ acc. to EN 1254-4  
 \_\_\_\_\_ Internal thread (G), ISO 228/1  
 \_\_\_\_\_ External thread (R), EN 10226-1

Material  
 Nut: \_\_\_\_\_ Brass CW 614N  
 Connection piece: \_\_\_\_\_ Dezincification resistant brass, DZR\*  
 Gasket: \_\_\_\_\_ Klingersil C-4400

\* Suitable for drinking water applications

PED 2014/68/EU, article 4.3

### KTD212, KTD312 External thread

Art. No.	Reference	Valve thread	Connection	Dimension		Weight [kg]	Note
				C	D		
36552200	KTD212	G 1"	R ¾"	43	35	0,36	2)
36552400	KTD312					0,36	1)
36552300	KTD212	G 1¼"	R 1"	48,5	40	0,63	2)
36552500	KTD312					0,63	1)

Notes: 1) 3 connections/package, Two check valves included 2) 3 connections/package, One check valve included











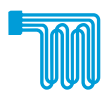

# THERMOSTATIC MIXING VALVES

## SELECTION GUIDE

### SELECTION GUIDE FIND THE RIGHT VALVE FOR YOU

The table below and the following pages is a toolbox for finding the best valve for your system and application. You will also find smaller selection tables in the product pages.

		APPLICATION					
Flow direction	Temp. range	Potable water, in line	Potable water, point of use	Solar heating	Cooling	Under floor heating	Radiator heating
							
	10 - 30°C				VTA570		
	20 - 43°C	VTA320 VTA520				VTA320 VTA520	
	20 - 55°C					VTA370 VTA570	VTA370 VTA570
	30 - 70°C	VTA310 VTA320					VTA370 VTA570 VTA320
	32 - 49°C	VTA330	VTA330			VTA330	
	35 - 50°C	VTA530				VTA530	
	35 - 60°C	VTA310 VTA320 VTA330	VTA330				VTA320 VTA330
	45 - 65°C	VTA520 VTA530 VTS520		VTS520			VTA520 VTA530 VTS520
	50 - 75°C	VTA520 VTS520		VTS520			VTA520 VTS520
	20 - 43°C	VTA550				VTA550	
	32 - 49°C	VTA360	VTA360			VTA360	
	35 - 50°C	VTA560				VTA560	
	35 - 60°C	VTA350 VTA360	VTA360				VTA360
	45 - 65°C	VTA550 VTA560 VTS550		VTS550			VTA550 VTA560 VTS550
	50 - 75°C	VTA550 VTS550		VTS550			VTA550 VTS550

-  Recommended alternative
-  Secondary alternative

## THERMOSTATIC MIXING VALVES DIMENSIONING

### DIMENSIONING OF DOMESTIC WATER APPLICATIONS

The thermostatic mixing valves for domestic hot water applications can be dimensioned according to the number of households in the house or the number of showers in, for example sports centers.

The ESBE thermostatic mixing valves are available with Kvs-values from 1,2 up to 4,8 and is to be dimensioned as below.

### RECOMMENDED KVS-VALUES

Kvs	Typical households <sup>1)</sup>	Showers <sup>2)</sup>	Shower heads <sup>3)</sup>	Under floor heating <sup>4)</sup>	Radiator heating <sup>5)</sup>
	Quantity*	Quantity*	Quantity*	m <sup>2</sup>	kW
1,2 - 1,3	1	2	2	< 80	< 12
1,5 - 1,6	≤ 3	3	2	40 - 105	6 - 16
2,2 - 2,5	≤ 6	5	3	60 - 165	10 - 26
3,0 - 3,2	≤ 15	6	4	75 - 210	12 - 33
3,4 - 3,6	≤ 20	7	5	85 - 230	13 - 36
4,5 - 4,8 <sup>6)</sup>	—	—	—	110 - 315	18 - 49

\* Number of households in the house or the number of showers in, for example sports centers.

1) A typical household consist of bath, shower, kitchen sink and washbasin with a design flow evaluated from probability curve in reference with EN 806-3:2006, and with a supply pressure >300kPa (3 bar). ESBE recommends max. allowed pressure drop (instant use) over valve <200 kPa (2 bar)

2) Showers in for example sport centers (simultaneous usage) meaning supply of scald safe hot water to shower mixer with supply pressure >300kPa (3 bar)

3) Showers in for example sport centers (simultaneous usage) meaning supply of scald safe mixed water to shower head with supply pressure >300kPa (3 bar)

4) Under floor heating calculated for: q = 55W/m<sup>2</sup>, Δt = 7K and Δp = 3-20kPa

5) Power calculated for: Δt = 20K and Δp = 3-20kPa

6) Kvs-values available only for heating valves

### CAPACITY DIAGRAM

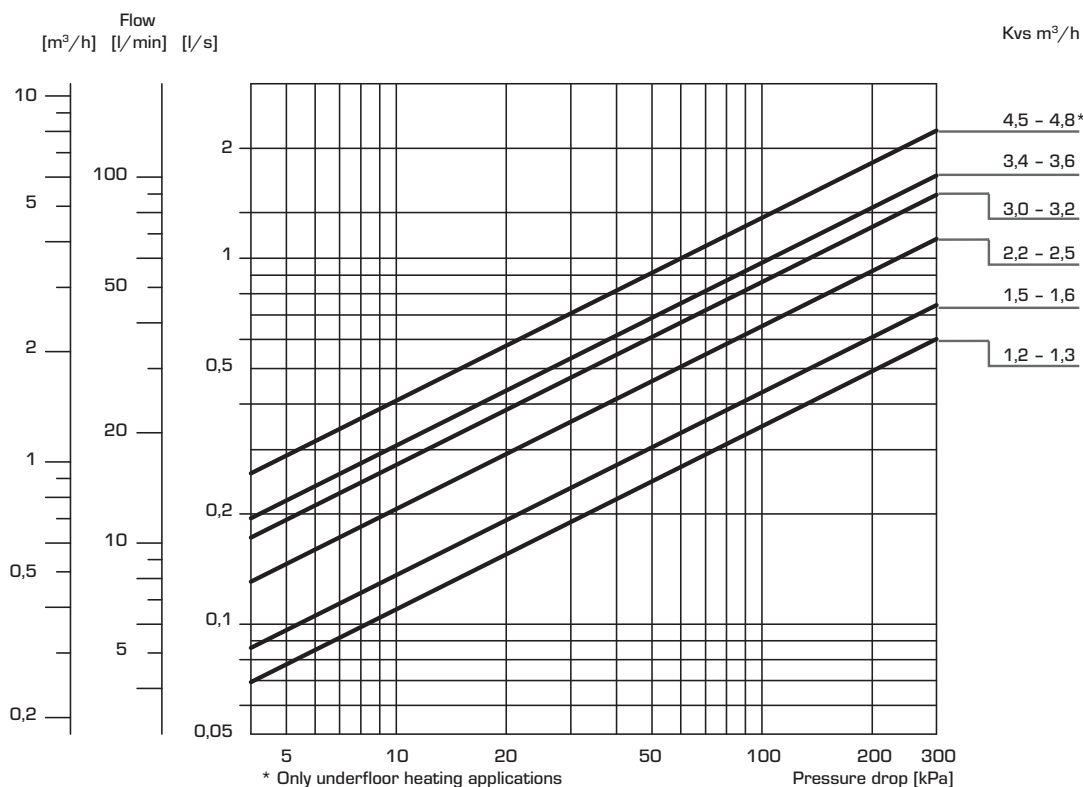

# THERMOSTATIC MIXING VALVES

## SELECTION GUIDE : INSTALLATION EXAMPLES

### FACTORS BEHIND HIGH OPERATING SAFETY

To achieve a good and safe function it is important to follow the installation instructions. This applies to all products, including the ESBE thermostatic mixing valves!

### PERIODIC FUNCTION CONTROL - CAUSE OF FAILURE

The function of the mixing valve is especially important at scald safe installations. We recommend performing a periodic check of the function at least once a year. Adjust the mixing temperature if required. If the required temperature cannot be achieved, a valve insert exchange may be required.

### SERVICE AND MAINTENANCE

Under normal conditions maintenance will not be required for ESBE thermostatic mixing valves. If, however, it should prove necessary, the seals (O-rings), the sensing element and the valve plug are easily replaced.

NOTE! Before dismantling the valve the water supply should be shut off. Where the valve is fitted below the storage tank this should be drained first.

### INSTALLATION

The thermostatic mixing valve should not be under constant thermal load. We therefore recommend heat traps in the piping arrangement. This should be taken into account during installation.

The mixing valve function regardless of mounting position.

### APPLICATION EXAMPLES - DOMESTIC HOT WATER

The ESBE thermostatic mixing valves can be used in a great number of applications. Please see the illustrations below for examples of how to install the thermostatic mixing valves in a domestic hot water system.

#### CONNECTION OF THE SERIES VTA330/VTA360 AT A WASHBASIN

In applications with high requirements for scald safety (hospitals, child care centers etc.) and/or quick and exact regulation accuracy, the series VTA330/VTA360 is the recommended choice.

Please see below for two illustrations of connections at a washbasin. The two mixing valve inlets shall be equipped with check valves.

**(A) VTA330**

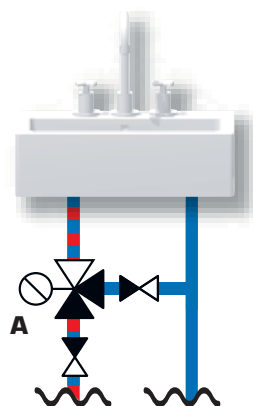

**(A) VTA360**

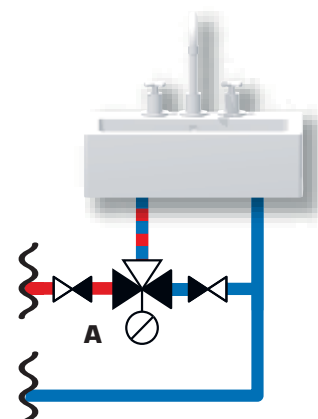

## THERMOSTATIC MIXING VALVES SELECTION GUIDE : INSTALLATION EXAMPLES

### DOMESTIC HOT WATER WITHOUT HWC\*

If no hot-water circulation exists, the valve should be equipped with hot-water blocking devices (heat traps) in the hot-water and the cold-water feed line.

\* HWC = Hot-water circulation

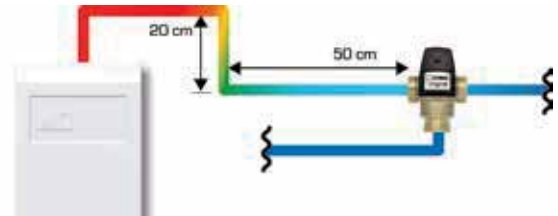

- (A) VTA320/VTA310/VTA520
- (B) VTA530

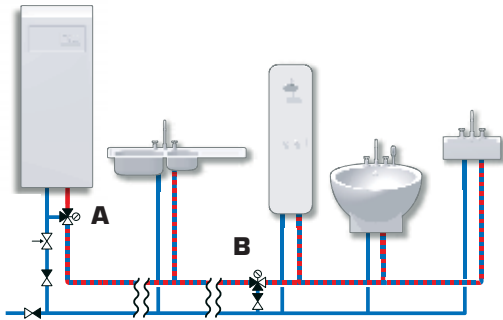

### TAP WATER WITH HWC\*

To get access to hot-water at a tap without waiting, an HWC-pipe with circulation pump should be installed. Connect each tap to the HWC-pipe. N.B! series VTA310 is not suitable for HWC.

\* HWC = Hot-water circulation

- (A) VTA320/VTA520/VTA530/VTS520

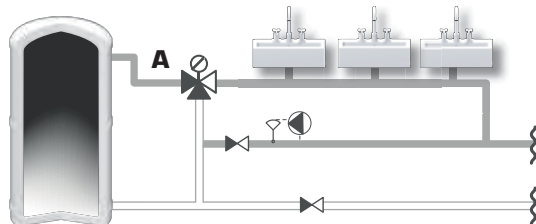

- (A) VTR300/VTR500

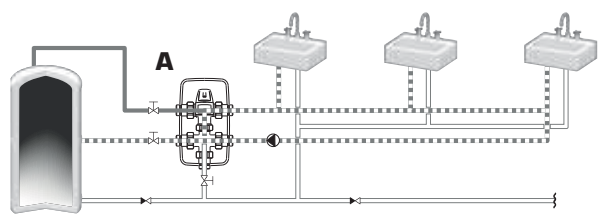

# THERMOSTATIC MIXING VALVES

## SELECTION GUIDE : INSTALLATION EXAMPLES

When refurbishing your home you may wish to install an underfloor heating in the bathroom, in the entrance or in any other room. ESBE thermostatic mixing valves series VTA300 alt. series VTA500 offer a simple and economical solution for underfloor heating regulation. The advantage of choosing a thermostatic mixing valve for underfloor heating applications is that it limits the supply line temperature without any needs for an automatic control device/bypass.

### APPLICATION EXAMPLES - UNDERFLOOR HEATING

There are some differences in regulating underfloor heating compared to radiator systems, such as;

- 1) The supply line temperature should not exceed 55°C.  
For concrete beams normally 40°C is enough, timber joist floor, however, can require up to 55°C.
- 2) The difference between the supply line temperature and the return temperature  $\Delta t$  is lower, normally 5°C

### DIMENSIONING OF UNDERFLOOR HEATING

Normal power requirement = 50 W/m<sup>2</sup>.  $\Delta t = 5^\circ\text{C}$  requires a flow of approx. 0,25 l/s per 100 m<sup>2</sup>.

Ex.: A valve of type VTA320 DN20 manages approx. 50 m<sup>2</sup> with a pressure drop of 8 kPa and VTA520 DN25 approx. 150 m<sup>2</sup> with a pressure drop of 10 kPa. For more details on dimensioning in heating applications, see diagrams in chapter "Rotary motorized valves".

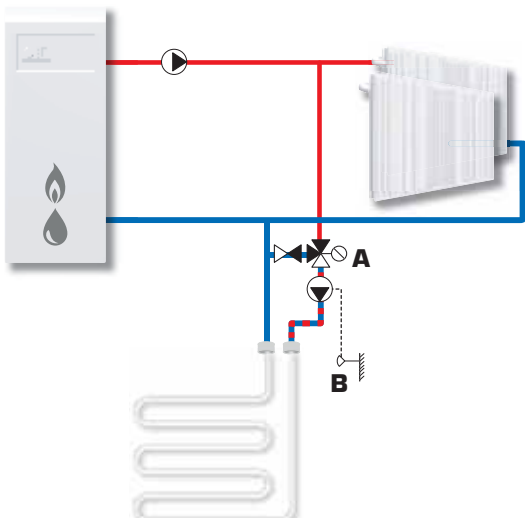
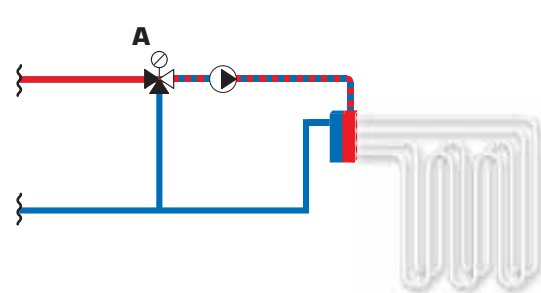
<p><b>ONE UNDERFLOOR HEATING LOOP</b></p> <p>The mixing valve has a constant temperature regulation at the set value. Please note that the underfloor heating circuit requires a separate circulation pump and that it can be equipped with a sensor.</p>	<p><b>SEVERAL UNDERFLOOR HEATING LOOPS</b></p> <p>The mixing valve has a constant temperature regulation at the set value. This type of application requires valves to balance the flow between the different underfloor heating circuits. For room control facilities, valves with separate sensors can be installed.</p>
<p><b>(A)</b> VTA320/VTA370/VTA520/VTA570 <b>(B)</b> Separate room sensor series Tx which starts and stops the required pump, if room control is required.</p> 	<p><b>(A)</b> VTA320/VTA370/VTA520/VTA570</p> 

## THERMOSTATIC MIXING VALVES SELECTION GUIDE : INSTALLATION EXAMPLES

To connect two thermostatic mixing valves in series can be beneficial whenever you have a storage tank with a two level domestic hot water outlet or when the hot water is processed in two different heaters. Preference can then be given to the most effective option.

ESBE thermostatic mixing valves can also be suitable for obtaining the highest possible level of energy from the most beneficial heat source of the system.

### APPLICATION EXAMPLES - SOLAR HEATING AND OTHERS

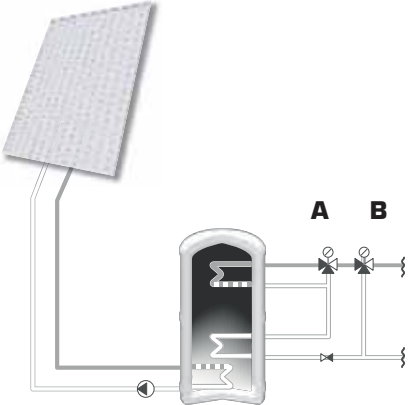
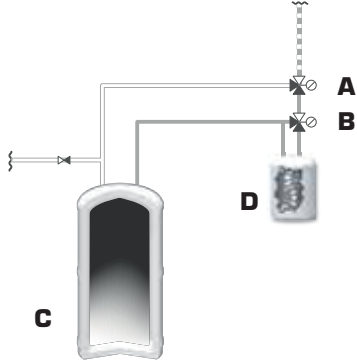
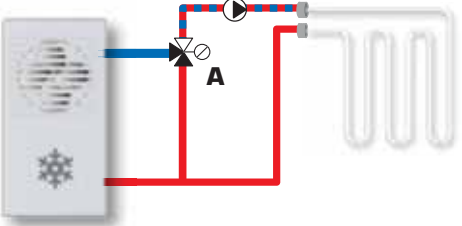
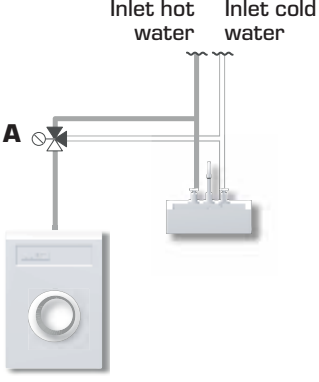
<p><b>IN SERIES WITH DOUBLE LOOPS</b> Series connection in hot-water heaters with double loops. Should the temperature in the bottom loop be insufficient, the top one will provide the peak heat.</p>	<p><b>TWO HEATERS IN SERIES</b> Series connection of two heaters. Should the temperature in the first heater be insufficient, the second heater will provide the peak heat. N.B.! Heater No. 2 must constantly be kept hot to avoid cold water addition.</p>
<p><b>(A)</b> VTS520/VTA520/(VTA320) <b>(B)</b> VTA520/VTA 320</p> 	<p><b>(A)</b> VTS520/VTA520/(VTA320) <b>(B)</b> VTA520/VTA 320 <b>(C)</b> Heater 1, Storage tank or heat pump <b>(D)</b> Heater 2, Electrical backup heating</p> 
<p><b>COOLING</b> A mixing valve has a constant temperature regulation at the set value. The high kvs value and the specific temperature range of the VTA570 series are suitable for cooling application.</p>	<p><b>HOT WATER TO A WASHING MACHINE</b> A mixing valve can be used to temper the hot water for a washing machine. This can be cost-effective if you have access to hot water from a solar collector, heatpump or a solid fuel system. In this case, the mixing valve is equipped with an adjusting knob to easily adjust to the desired washing temperature. Maximum recommended mixed water temperature setting: 40°C.</p>
<p><b>(A)</b> VTA570</p> 	<p><b>(A)</b> VTA320</p> 

# LINEAR VALVES

## EXCELLENT REGULATION

**Our range of linear motorized valves** includes several innovative solutions for applications in district heating stations, central heating systems and district cooling and hot tap water systems. All ensure precise adjustment and problem-free operation for many years.



### Valve operation overview

2-way valve



3-way valve







Patented

## CONTROL VALVE Series VLF100

- **Superb regulation for best mixing and flow regulating performance up to 6 bar (PN6)**
- **Real low internal leakrate and 100% tested product**
- **Long lasting and high durability**
- **Perfect match between the valve and ESBE actuators**

Series VLF are 2-way and 3-way control valves with flange connection PN6, suitable for mixing and flow regulation up to 6 bar. The valves are made for use in heating and cooling installations. The VLF series is available in 2-way DN15-DN50 ; 3-way DN15-DN50 and comes with a PN6 flange to suit PN6 flange pipe connections. The valve is perfectly combined with ESBE actuators.

### TECHNICAL DATA

Type: \_\_\_\_\_ 2- and 3-way plug valve  
 Pressure class: \_\_\_\_\_ PN 6  
 Flow characteristic A-AB: \_\_\_\_\_ EQM  
 Flow characteristic B-AB: \_\_\_\_\_ Complementary  
 Stroke: \_\_\_\_\_ 20 mm  
 Rangeability  $K_v/K_v^{min}$ : \_\_\_\_\_ see table  
 Leakrate A-AB: \_\_\_\_\_ Tight sealing  
 Leakrate B-AB: \_\_\_\_\_ Tight sealing  
 $\Delta P_{max}$ : \_\_\_\_\_ see tables pages 152 - 155  
 Media temperature: \_\_\_\_\_ max. +120°C, min. -20°C  
 Connection: \_\_\_\_\_ Flange, ISO 7005-2  
 Media: \_\_\_\_\_ Heating water (in accordance with VDI2035)  
 \_\_\_\_\_ Water / Glycol mixtures, max. 50%  
 (above 20% admixture, the pumping data must be checked)

Material  
 Body, Seat: \_\_\_\_\_ Nodular iron EN-JS 1030  
 Stem: \_\_\_\_\_ Stainless steel SS 2346  
 Plug, Blind plug: \_\_\_\_\_ Brass CW602N  
 Seat seal: \_\_\_\_\_ EPDM  
 Packing box seal: \_\_\_\_\_ PTFE / EPDM

PED 2014/68/EU, article 4.3

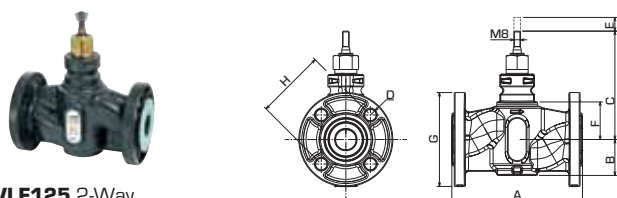

**VLF125** 2-Way

Art. No.	Reference	DN	Kvs	A	B	C	D	E	F	G	H	Rangeability $K_v/K_v^{min}$	Weight [kg]	Note
21000400	VLF125	20	6,3	150	44	126	4x11	20	41	90	65	>50	2,4	1)
21000500		25	10	160	44	131	4x11	20	46	100	75	>50	2,9	
21000600		32	16	180	58	144	4x14	20	60	120	90	>50	4,2	
21000700		40	25	200	60	146	4x14	20	61	130	100	>50	5,4	
21000800		50	38	230	74	161	4x14	20	76	140	110	>50	6,7	

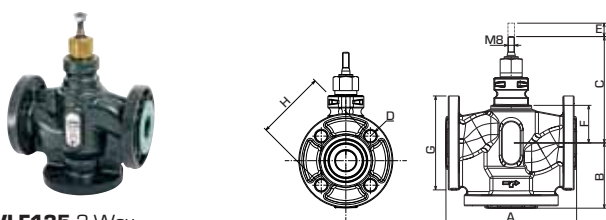

**VLF135** 3-Way

Art. No.	Reference	DN	Kvs	A	B	C	D	E	F	G	H	Rangeability $K_v/K_v^{min}$	Weight [kg]	Note
21001200	VLF135	20	6,3	150	75	126	4x11	20	41	90	65	>50	2,9	1)
21001300		25	10	160	80	131	4x11	20	46	100	75	>50	3,4	
21001400		32	16	180	90	144	4x14	20	60	120	90	>50	6,0	
21001500		40	25	200	100	146	4x14	20	61	130	100	>50	6,5	
21001600		50	38	230	115	161	4x14	20	76	140	110	>50	8,2	



### ADDITIONAL GUIDANCE

Guide & Dimensioning..... 152–157  
 Installation examples.....160

For further detailed information ..... [www.esbe.eu](http://www.esbe.eu)

Notes: 1) With premounted flange gasket

Patented



## CONTROL VALVE Series VLA100

- **Superb regulation for best mixing and flow regulating performance up to 16 bar (PN16)**
- **Superb low internal leakrate and 100% tested product**
- **Long lasting and high durability**
- **Perfect match between the valve and ESBE actuators**

Series VLA are 2-way and 3-way control valves suitable for mixing and flow regulation up to 16 bar. The valves are made of high-performing nodular iron allowing use in heating and cooling installations. The VLA series is available in 2-way DN15-DN50 ; 3-way DN15-50 and comes with one type of connection. The valve is perfectly combined with ESBE actuators.

### TECHNICAL DATA

Type: \_\_\_\_\_ 2- and 3-way plug valve  
 Pressure class: \_\_\_\_\_ PN 16  
 Flow characteristic A-AB: \_\_\_\_\_ EQM  
 Flow characteristic B-AB: \_\_\_\_\_ Complementary  
 Stroke: \_\_\_\_\_ 20 mm  
 Rangeability Kv/Kv<sup>min</sup>: \_\_\_\_\_ see table  
 Leakrate A-AB: \_\_\_\_\_ Tight sealing  
 Leakrate B-AB: \_\_\_\_\_ Tight sealing  
 ΔPmax: \_\_\_\_\_ see tables pages 152 - 155  
 Media temperature: \_\_\_\_\_ max. +130°C  
 \_\_\_\_\_ min. -20°C  
 Connection: \_\_\_\_\_ Internal thread (Rp), EN 10226-1  
 Media: \_\_\_\_\_ Heating water (in accordance with VDI2035)  
 \_\_\_\_\_ Water / Glycol mixtures, max. 50%  
 (above 20% admixture, the pumping data must be checked)  
 Material  
 Body, Seat: \_\_\_\_\_ Nodular iron EN-JS 1030  
 Stem: \_\_\_\_\_ Stainless steel SS 2346  
 Plug, Blind plug: \_\_\_\_\_ Brass CW602N  
 Seat seal: \_\_\_\_\_ EPDM  
 Packing box seal: \_\_\_\_\_ PTFE/EPDM  
 PED 2014/68/EU, article 4.3

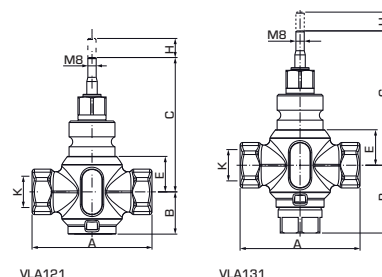

### VLA121 2-Way

Art. No.	Reference	DN	Kvs	A	B	C	E	H	K	Rangeability Kv/Kv <sup>min</sup>	Weight [kg]	Note
21150100	VLA121	15	1,6	85	38	108	24	20	Rp ½"	>50	1,0	
21150200			2,5									
21150300			4									
21150400		20	6,3	100	40	115	30	20	Rp ¾"	>50	1,2	
21150500		25	10	115	40	119	34	20	Rp 1"	>50	1,3	
21150600		32	16	130	41	120	35	20	Rp 1¼"	>50	1,8	
21150700		40	25	150	50	128	42	20	Rp 1½"	>50	2,7	
21150800		50	38	180	59	138	53	20	Rp 2"	>50	4,2	

### VLA131 3-Way

Art. No.	Reference	DN	Kvs	A	B	C	E	H	K	Rangeability Kv/Kv <sup>min</sup>	Weight [kg]	Note
21150900	VLA131	15	1,6	85	58	108	24	20	Rp ½"	>50	1,1	
21151000			2,5									
21151100			4									
21151200		20	6,3	100	61	115	30	20	Rp ¾"	>50	1,3	
21151300		25	10	115	65	119	34	20	Rp 1"	>50	1,5	
21151400		32	16	130	70	120	35	20	Rp 1¼"	>50	2,1	
21151500		40	25	150	74	128	42	20	Rp 1½"	>50	3,0	
21151600		50	38	180	90	138	53	20	Rp 2"	>50	4,7	



### ADDITIONAL GUIDANCE

Guide & Dimensioning..... 152–157  
 Installation examples.....160

For further detailed information ..... [www.esbe.eu](http://www.esbe.eu)



Patented

**CONTROL VALVE**  
Series VLA300, VLB300

- **Superb regulation for best mixing and flow regulating performance up to 16 bar (PN16)**
- **Real low internal leakrate and 100% tested product**
- **Long lasting and high durability**
- **Perfect match between the valve and ESBE actuators**

Series VLA-VLB are 2-way and 3-way control valves with flange connection PN16 and higher flow rates, suitable for mixing and flow regulation up to 16 bar. The valves are made for use in heating and cooling installations. The VLA-VLB series is available in 2-way DN15-DN150 ; 3-way DN15-150 and comes with one type of connection. The valve is perfectly combined with ESBE actuators.

**TECHNICAL DATA**

Type: \_\_\_\_\_ 2- and 3-way plug valve  
 Pressure class: \_\_\_\_\_ PN 16  
 Flow characteristic A-AB: \_\_\_\_\_ EQM  
 Flow characteristic B-AB, DN 15-50: \_\_\_\_\_ Complementary  
 DN 65-150: \_\_\_\_\_ Linear  
 Stroke, DN 15-50: \_\_\_\_\_ 20 mm  
 DN 65: \_\_\_\_\_ 25 mm  
 DN 80-150: \_\_\_\_\_ 45 mm  
 Rangeability Kv/Kv<sup>min</sup>: \_\_\_\_\_ see table  
 Leakrate A-AB, DN 15-50: \_\_\_\_\_ Tight sealing  
 DN 65-150: \_\_\_\_\_ 0,03% of Kvs  
 Leakrate B-AB, DN 15-50: \_\_\_\_\_ Tight sealing  
 DN 65-150: \_\_\_\_\_ 2% of Kvs  
 ΔPmax, DN 15-50: \_\_\_\_\_ see tables pages 152 - 155  
 DN 65-150: \_\_\_\_\_ Mixing: 200 kPa (2 bar)  
 \_\_\_\_\_ Diverting: 70 kPa (0,7 bar)  
 Media temperature, DN 15-50: \_\_\_\_\_ max. +130°C  
 \_\_\_\_\_ min. -20°C  
 DN 65-150: \_\_\_\_\_ max. +150°C  
 \_\_\_\_\_ min. -10°C  
 Connection: \_\_\_\_\_ Flange, ISO 7005-2  
 Media: \_\_\_\_\_ Heating water (in accordance with VD12035)  
 \_\_\_\_\_ Water / Glycol mixtures, max. 50%  
 (above 20% admixture, the pumping data must be checked)

Material DN 15 - 50  
 Body, Seat: \_\_\_\_\_ Nodular iron EN-JS 1030  
 Stem: \_\_\_\_\_ Stainless steel SS 2346  
 Plug, Blind plug: \_\_\_\_\_ Brass CW602N  
 Seat seal: \_\_\_\_\_ EPDM  
 Packing box seal: \_\_\_\_\_ PTFE/EPDM

Material DN 65 - 150  
 Body, Seat: \_\_\_\_\_ Grey cast iron EN-JL 1040  
 Stem: \_\_\_\_\_ Stainless steel DIN 1.4305  
 Plug: \_\_\_\_\_ Brass CW617N  
 Seat seal: \_\_\_\_\_ Metallic  
 Packing box seal: \_\_\_\_\_ EPDM

DN15-50 PED 2014/68/EU, article 4.3  
 DN65-150 PED 2014/68/EU, Annex IV



**VLA325 2-Way**

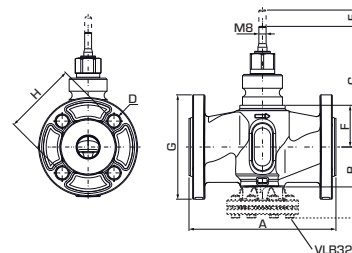

Art. No.	Reference	DN	Kvs	A	B	C	D	E	F	G	H	Rangeability Kv/Kv <sup>min</sup>	Weight [kg]	Note
21200100	VLA325	15	1,6	130	42	123	4x14	20	38	95	65	>50	2,1	1)
21200200			2,5											
21200300			4											
21200400		20	6,3	150	44	126	4x14	20	41	105	75	>50	2,6	
21200500		25	10	160	44	131	4x14	20	46	115	85	>50	3,2	
21200600		32	16	180	58	144	4x19	20	60	140	100	>50	4,6	
21200700		40	25	200	60	146	4x19	20	61	150	110	>50	5,8	
21200800		50	38	230	74	161	4x19	20	76	165	125	>50	8,0	



**ADDITIONAL GUIDANCE**

Guide & Dimensioning..... 152—156, 158  
 Installation examples.....160

For further detailed information ..... [www.esbe.eu](http://www.esbe.eu)

Notes: 1) With premounted flange gasket

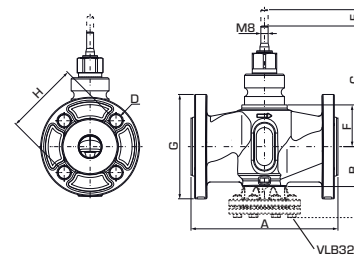

**VLB325 2-Way**

Art. No.	Reference	DN	Kvs	A	B	C	D	E	F	G	H	Rangeability Kv/Kv <sup>min</sup>	Weight [kg]	Note
21220100	VLB325	65	63	290	175	155	4x18	25	95	185	145	>50	23,0	
21220200		80	100	310	187	165	8x18	45	105	200	160	>50	30,0	
21220300		100	130	350	207	176	8x18	45	116,5	220	180	>50	45,6	
21220400		125	200	400	234	199	8x18	45	139	250	210	>50	55,0	
21220500		150	300	480	277	217	8x22	45	157	285	240	>50	71,0	

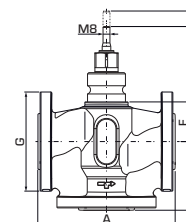

**VLA335, VLB335 3-Way**

Art. No.	Reference	DN	Kvs	A	B	C	D	E	F	G	H	Rangeability Kv/Kv <sup>min</sup>	Weight [kg]	Note
21200900	VLA335	15	1,6	130	65	123	4x14	20	38	95	65	>50	2,5	1)
21201000			2,5											
21201100			4											
21201200		20	6,3	150	75	126	4x14	20	41	105	75	>50	3,2	
21201300		25	10	160	80	131	4x14	20	46	115	85	>50	3,8	
21201400		32	16	180	90	144	4x19	20	60	140	100	>50	6,6	
21201500		40	25	200	100	146	4x19	20	61	150	110	>50	7,5	
21201600	50	38	230	115	161	4x19	20	76	165	125	>50	10,0		
21221100	VLB335	65	63	290	145	155	4x18	25	95	185	145	>50	19,0	
21221200		80	100	310	155	165	8x18	45	105	200	160	>50	24,0	
21221300		100	130	350	175	176	8x18	45	116,5	220	180	>50	32,0	
21221400		125	200	400	200	199	8x18	45	139	250	210	>50	46,0	
21221500		150	300	480	240	217	8x22	45	157	285	240	>50	61,0	



**ADDITIONAL GUIDANCE**

Guide & Dimensioning..... 152–156, 158  
 Installation examples.....160

For further detailed information ..... [www.esbe.eu](http://www.esbe.eu)

Notes: 1) With premounted flange gasket

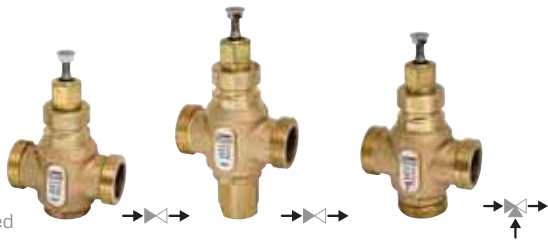

Patented

**CONTROL VALVE**  
Series VLE100, VLE200

- **Superb regulation for best mixing, diverting ( $\Delta P < 50\text{kPa}$ ) and flow regulating performance up to 16 bar (PN16)**
- **Real low internal leakrate and 100% tested product**
- **Long lasting and high durability**
- **Pressure balancing plug available**
- **Perfect match between the valve and ESBE actuators**

Series VLE are 2-way and 3-way control valves suitable for mixing, diverting ( $\Delta P < 50\text{kPa}$ ) and flow regulation up to 16 bar. The valves are made of high-performing bronze allowing use in heating and cooling installations. The VLE series is available in 2-way DN15-DN50 ; 2-way with pressure balancing plug DN25-DN50 ; 3-way DN15-50 and comes with one type of connection. The valve is perfectly combined with ESBE actuators.

**TECHNICAL DATA**

Type: \_\_\_\_\_ 2- and 3-way plug valve  
 Pressure class: \_\_\_\_\_ PN 16  
 Flow characteristic A-AB: \_\_\_\_\_ EGM  
 Flow characteristic B-AB: \_\_\_\_\_ Complementary  
 Stroke: \_\_\_\_\_ 20 mm  
 Rangeability  $K_v/K_v^{\text{min}}$ : \_\_\_\_\_ see table  
 Leakrate A-AB - DN15: \_\_\_\_\_ max. 0,02% of  $K_v$  4  
 - DN 20-50: \_\_\_\_\_ max. 0,02% of  $K_v$  5  
 Leakrate B-AB - DN15: \_\_\_\_\_ max. 0,05% of  $K_v$  4  
 - DN 20-50: \_\_\_\_\_ max. 0,05% of  $K_v$  5  
 $\Delta P_{\text{max}}$ : \_\_\_\_\_ see tables pages 152 - 155  
 Media temperature: \_\_\_\_\_ max. +150°C  
 \_\_\_\_\_ min. -20°C  
 Connection: \_\_\_\_\_ External pipe thread (G), ISO 228/1  
 Media: \_\_\_\_\_ Heating water (in accordance with VDI2035)  
 \_\_\_\_\_ Water / Glycol mixtures, max. 50%  
 (above 20% admixture, the pumping data must be checked)  
 Material  
 Body: \_\_\_\_\_ Bronze Rg5  
 Stem, Plug, Seat: \_\_\_\_\_ Stainless steel SS 2346  
 Blind plug: \_\_\_\_\_ Brass CW602N  
 Seat seal: \_\_\_\_\_ Metallic  
 Packing box seal: \_\_\_\_\_ PTFE/EPDM  
 PED 2014/68/EU, article 4.3

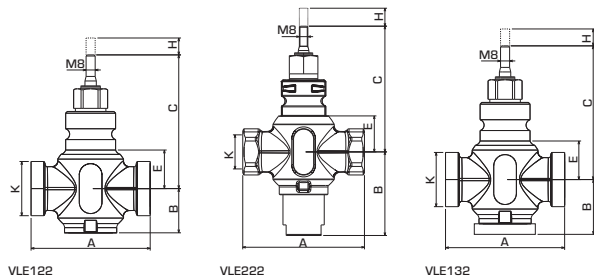

**VLE122 2-Way**

Art. No.	Reference	DN	Kvs	A	B	C	E	H	K	Rangeability $K_v/K_v^{\text{min}}$	Weight [kg]	Note
21250100	VLE122	15	0,25	100	36	110	24	20	G 1"	>50	1,0	
21250200			0,4									
21250300			0,63									
21250400			1									
21250500			1,6									
21250600			2,5									
21250700		4										
21250800		20	6,3	100	38	116	30	20	G 1 1/4"	>100	1,2	
21250900		25	10	105	39	120	34	20	G 1 1/2"	>100	1,4	
21251000		32	16	105	39	121	35	20	G 2"	>100	1,8	
21251100	40	25	130	48	128	42	20	G 2 1/4"	>100	2,6		
21251200	50	38	150	58	139	53	20	G 2 3/4"	>100	4,3		

**VLE222 2-Way, with pressure balanced plug**

Art. No.	Reference	DN	Kvs	A	B	C	E	H	K	Rangeability $K_v/K_v^{\text{min}}$	Weight [kg]	Note
21252100	VLE222	25	10	105	78	120	34	20	G 1 1/2"	>100	1,4	
21252200		32	16	105	81	121	35	20	G 2"	>100	1,8	
21252300		40	25	130	78	128	42	20	G 2 1/4"	>100	2,6	
21252400		50	38	150	80	139	53	20	G 2 3/4"	>100	4,3	

**VLE132 3-Way**

Art. No.	Reference	DN	Kvs	A	B	C	E	H	K	Rangeability $K_v/K_v^{\text{min}}$	Weight [kg]	Note
21251300	VLE132	15	1,6	100	50	110	24	20	G 1"	>50	1,1	
21251400			2,5									
21251500			4									
21251600		20	6,3	100	50	116	30	20	G 1 1/4"	>100	1,3	
21251700		25	10	105	52	120	34	20	G 1 1/2"	>100	1,6	
21251800		32	16	105	52	121	35	20	G 2"	>100	2,0	
21251900		40	25	130	65	128	42	20	G 2 1/4"	>100	2,9	
21252000		50	38	150	75	139	53	20	G 2 3/4"	>100	4,6	



Patented



## CONTROL VALVE Series VLE300

- Especially designed for replacements of STL-valves in existing applications up to 16 bar (PN16)
- Real low internal leakrate and 100% tested product
- Long lasting and high durability
- Perfect match between the valve and ESBE actuators

Series VLE325 is a 2-way PN16 flanged control valve, especially designed for replacement of STL valves in existing applications for flow regulation up to 16 bar. The valves are made of high-performing bronze allowing use in heating and cooling installations. The VLE325 is available in 2-way DN20-40 and comes with a PN16 flange to suit PN16 flange pipe connections. The valve is perfectly combined with ESBE actuators and controllers.

### TECHNICAL DATA

Type: \_\_\_\_\_ 2-way plug valve  
 Pressure class: \_\_\_\_\_ PN 16  
 Flow characteristic A-AB: \_\_\_\_\_ EQM  
 Stroke: \_\_\_\_\_ 20 mm  
 Rangeability Kv/Kv<sup>min</sup>: \_\_\_\_\_ see table  
 Leakrate A-AB - DN 20-25: \_\_\_\_\_ max. 0,02% of Kv 4  
 - DN 32-40: \_\_\_\_\_ max. 0,02% of Kv 6,3  
 ΔP<sub>max</sub>: \_\_\_\_\_ see tables pages 152 - 155  
 Media temperature: \_\_\_\_\_ max. +130°C  
 \_\_\_\_\_ min. -20°C  
 Connection: \_\_\_\_\_ Flange, ISO 7005-2  
 Media: \_\_\_\_\_ Heating water (in accordance with VDI2035)  
 \_\_\_\_\_ Water / Glycol mixtures, max. 50%  
 (above 20% admixture, the pumping data must be checked)

Material  
 Body: \_\_\_\_\_ Bronze Rg5  
 Flanges: \_\_\_\_\_ Steel SS 1914  
 Stem, Plug, Seat: \_\_\_\_\_ Stainless steel SS 2346  
 Blind plug: \_\_\_\_\_ Brass CW602N  
 Seat seal: \_\_\_\_\_ Metallic  
 Packing box seal: \_\_\_\_\_ PTFE/EPDM

PED 2014/68/EU, article 4.3

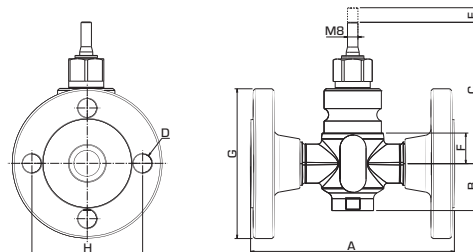

### VLE325 2-Way

Art. No.	Reference	DN	Kvs	A	B	C	D	E	F	G	H	Rangeability Kv/Kv <sup>min</sup>	Weight [kg]	Note
21400100	VLE325	20	0,63	143	36	110	4x14	20	24	105	75	>100	3,0	
21400200			1											
21400300			1,6											
21400400			2,5											
21400500			4											
21400600	VLE325	25	1	156	36	110	4x14	20	24	115	85	>100	3,7	
21400700			1,6											
21400800			2,5											
21400900			4											
21401000	VLE325	32	1,6	165	36	110	4x18	20	24	140	100	>100	5,0	
21401100			2,5											
21401200			4											
21401600			6,3											
21401300	VLE325	40	1,6	170	36	110	4x18	20	24	150	110	>100	5,6	
21401400			2,5											
21401500			4											
21401700			6,3											



### ADDITIONAL GUIDANCE

Guide & Dimensioning.....152–156, 158–159  
 Installation examples.....160

For further detailed information ..... [www.esbe.eu](http://www.esbe.eu)

Note: \* ΔP<sub>max</sub> = Max. differential pressure for valve and actuator combinations.



Patented

**CONTROL VALVE**  
Series VLC100, VLC200

- **Superb regulation for best flow regulating performance up to 25 bar (PN25)**
- **Real low internal leakrate and 100% tested product**
- **Long lasting and high durability**
- **Pressure balancing plug available**
- **Perfect match between the valve and ESBE actuators**

Series VLC125-225 are 2-way control valves with flange connection PN25, suitable for flow regulation up to 25 bar. The valves are made of high-performing nodular iron allowing use in heating and cooling installations. The VLC series is available in 2-way DN15-DN50 ; 2-way with pressure balancing plug and comes with a PN25 flange to suit PN25 flange pipe connections. The valve is perfectly combined with ESBE actuators.

**TECHNICAL DATA**

Type: \_\_\_\_\_ 2-way plug valve  
 Pressure class: \_\_\_\_\_ PN25  
 Flow characteristic A-AB: \_\_\_\_\_ EQM  
 Stroke: \_\_\_\_\_ 20 mm  
 Rangeability Kv/Kv<sup>min</sup>: \_\_\_\_\_ see table  
 Leakrate A-AB - DN15: \_\_\_\_\_ max. 0,02% of Kvs 4  
 - DN25: \_\_\_\_\_ max. 0,02% of Kvs 10  
 - DN40: \_\_\_\_\_ max. 0,02% of Kvs 25  
 - DN20, DN32, DN50: \_\_\_\_\_ max. 0,02% of Kvs  
 ΔPmax: \_\_\_\_\_ see tables pages 152 - 155  
 Temperature of medium: \_\_\_\_\_ max. +150°C  
 \_\_\_\_\_ min. -20°C  
 Connection: \_\_\_\_\_ Flange, ISO 7005-2  
 Media: \_\_\_\_\_ Heating water (in accordance with VDI2035)  
 \_\_\_\_\_ Water / Glycol mixtures, max. 50%  
 (above 20% admixture, the pumping data must be checked)

Material  
 Body: \_\_\_\_\_ Nodular iron EN-JS 1030  
 Stem, Plug, Seat: \_\_\_\_\_ Stainless steel SS 2346  
 Seat seal: \_\_\_\_\_ Metallic  
 Packing box seal: \_\_\_\_\_ PTFE/EPDM

DN15-40 PED 2014/68/EU, article 4.3  
 DN50 PED 2014/68/EU, category I, Module A, Fluid group 2



**VLC125 2-Way**

**VLC225 2-Way, with pressure balanced plug.**

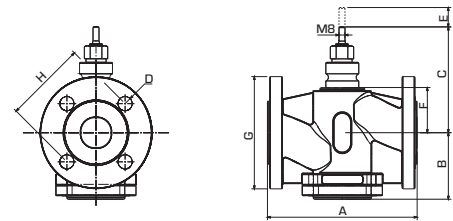

Art. No.	Reference	DN	Kvs	A	B	C	D	E	F	G	H	Rangeability Kv/Kv <sup>min</sup>	Weight [kg]	Note	
21300100	VLC125	15	0,25	130	81	122	4x14	20	37	95	65	>50	3,6		
21300200			0,4												
21300300			0,63												
21300400			1												
21300500			1,6												
21300600			2,5												
21300700			4												
21300800		20	6,3	150	92	124	4x14	20	40	105	75	>200	4,4		
21301700		25	1,6	160	96	130	4x14	20	45	115	85	85	>30	4,4	
21301800			2,5										>70		
21301900			4										>100		
21302000			6,3										>200		
21300900			10										>200		
21301000		32	16	180	100	143	4x19	20	58	140	100	>200	7,7		
21302100		40	1,6	200	99	144	4x19	20	60	150	110	110	>30	7,7	
21302200			2,5										>70		
21302300			4										>70		
21302400			6,3										>100		
21302500			10										>200		
21302600			16										>200		
21301100	25		>200												
21301200	50	38	230	111	160	4x19	20	75	165	125	>200	12,6			

Art. No.	Reference	DN	Kvs	A	B	C	D	E	F	G	H	Rangeability Kv/Kv <sup>min</sup>	Weight [kg]	Note
21301300	VLC225	25	10	160	96	130	4x14	20	45	115	85	>200	5,9	
21301400		32	16	180	100	143	4x19	20	58	140	100	>200	8,1	
21301500		40	25	200	99	144	4x19	20	60	150	110	>200	9,3	
21301600		50	38	230	111	160	4x19	20	75	165	125	>200	13,5	





KTB100  
Internal thread



KSB100  
Soldering type

## CONNECTION KITS

Options valves DN15–50

### SUITABLE VALVES

The connection kit series KTB112, KSB114 may most easily be fitted with ESBE control valve series VLE122, VLE222 and VLE132.

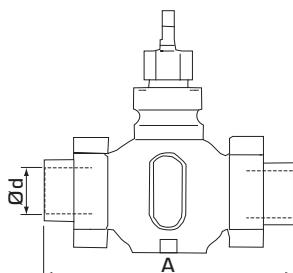

### TECHNICAL DATA

Max. working pressure: \_\_\_\_\_ PN 16  
 Max. temperature of medium: \_\_\_\_\_ +150°C  
 Min. temperature of medium: \_\_\_\_\_ -20°C  
 Connection: \_\_\_\_\_ Internal thread (Rp), EN 10226-1  
 \_\_\_\_\_ External thread (G), ISO 228/1

#### Material KTB112

Union nut: \_\_\_\_\_ Malleable iron casting, galv.  
 Union end: \_\_\_\_\_ Malleable iron casting, galv.  
 Standard gasket: \_\_\_\_\_ Klingersil C4400

#### Material KSB114

Union nut: \_\_\_\_\_ Brass, CW614N  
 Union end: \_\_\_\_\_ Bronze, SS5204  
 Standard gasket: \_\_\_\_\_ Klingersil C4400

### KTB112 Fittings Internal thread



Art. No.	DN	Valves thread	Connection Ød	A (VLE100/VLE200)	Weight [kg]	Note
26100700	15	G 1"	Rp 1/2"	146	0,12	1)
26100800	20	G 1 1/4"	Rp 3/4"	146	0,20	
26100900	25	G 1 1/2"	Rp 1"	159	0,23	
26101000	32	G 2"	Rp 1 1/4"	169	0,41	
26101100	40	G 2 1/4"	Rp 1 1/2"	197	0,45	
26101200	50	G 2 3/4"	Rp 2"	222	0,64	





### KSB114 Fittings Soldering type

Art. No.	DN	Valves thread	Connection Ød	A (VLE100/VLE200)	Weight [kg]	Note
26101300	15	G 1"	15 mm	136	0,13	1)
26101400	20	G 1 1/4"	22 mm	146	0,19	
26101500	25	G 1 1/2"	28 mm	155	0,23	
26101600	32	G 2"	35 mm	163	0,45	
26101700	40	G 2 1/4"	42 mm	200	0,48	
26101800	50	G 2 3/4"	54 mm	232	0,77	

Notes: 1) 1 connection/package

## LINEAR VALVES + ACTUATORS SELECTION GUIDE



			Force [N]	800	600	1000	1500	2200	900
			Stroke [mm]	52	30	60	60	60	30
			Running time [s]	15-60	15-60	15-60	15-60	60	15-300
			Actuator series	ALB	ALF				ALH
<b>ACTUATORS</b>									
Supply voltage	3-point	Proportional							
24 VAC	●	●	22050100						
24 V AC/DC	●	●		22201100	22201200	22201300	22201400		
230 VAC	●	●		22200100	22200200	22200300	22200400		
Safety function 24 V Spring return; Up ↑	●	●							† 22220100
Safety function 24 V Spring return; Down ↓	●	●							‡ 22221100

<b>2-WAY VALVES</b>													
PN [bar]	T [°C]	Series	Art. No.	DN	Kvs [m <sup>3</sup> /h]	Stroke [mm]	Δp max [kPa]	Δp max [kPa]	Δp max [kPa]	Δp max [kPa]	Δp max [kPa]	Δp max [kPa]	
6	-20 ... +120		VLF125	21000100	15	1,6	20	600	600	600			600
			21000200	15	2,5	20	600	600	600			600	
			21000300	15	4,0	20	600	600	600			600	
			21000400	20	6,3	20	600	600	600			600	
			21000500	25	10	20	600	600	600			600	
			21000600	32	16	20	600	600	600			600	
			21000700	40	25	20	570	570	600			600	
			21000800	50	38	20	390	270	450			400	
16	-20 ... +130		VLA325	21200100	15	1,6	20	1600	1200	1600	1600		1600
			21200200	15	2,5	20	1600	1200	1600	1600		1600	
			21200300	15	4,0	20	1600	1200	1600	1600		1600	
			21200400	20	6,3	20	1400	970	1550	1600		1400	
			21200500	25	10	20	1100	760	1250	1600		1120	
			21200600	32	16	20	800	550	900	1330		810	
			21200700	40	25	20	570	390	640	950		580	
			21200800	50	38	20	390	270	450	660		400	
16	-10 ... +150		VLB325	21220100	65	63	25	180		310	480	710	180
			21220200	80	100	45	110		200	310	460		
			21220300	100	130	45	70		120	190	280		
			21220400	125	200	45	40		70	120	180		
			21220500	150	300	45	30		50	80	120		
16	-20 ... +130		VLA425	21201700	25	10	20	1600	1320	1600	1600		1600
			21201800	32	16	20	1600	1320	1600	1600		1600	
			21201900	40	25	20	1600	1320	1600	1600		1600	
			21202000	50	38	20	1600	1320	1600	1600		1600	
16	-20 ... +130		VLA121	21150100	15	1,6	20	1600	1200	1600	1600		1600
			21150200	15	2,5	20	1600	1200	1600	1600		1600	
			21150300	15	4,0	20	1600	1200	1600	1600		1600	
			21150400	20	6,3	20	1400	970	1550	1600		1400	
			21150500	25	10	20	1100	760	1250	1600		1120	
			21150600	32	16	20	800	550	900	1330		810	
			21150700	40	25	20	570	390	640	950		580	
			21150800	50	38	20	390	270	450	660		400	



Δp max: Closing pressure. For further information about maximum pressure drop limits where cavitation might occur, see diagrams for each specific type of valve.

# LINEAR VALVES + ACTUATORS

## SELECTION GUIDE

			Force [N]	800	600	1000	1500	2200	900
			Stroke [mm]	52	30	60	60	60	30
			Running time [s]	15-60	15-60	15-60	15-60	60	15-300
			Actuator series	ALB	ALF				ALH
<b>ACTUATORS</b>									
Supply voltage	3-point	Proportional							
24 VAC	●	●	22050100						
24 V AC/DC	●	●		22201100	22201200	22201300	22201400		
230 VAC	●	●		22200100	22200200	22200300	22200400		
Safety function 24 V Spring return; Up ↑	●	●							† 22220100
Safety function 24 V Spring return; Down ↓	●	●							‡ 22221100



### 2-WAY VALVES

PN [bar]	T [°C]	Series	Art. No.	DN	Kvs [m <sup>3</sup> /h]	Stroke [mm]	Δp max [kPa]	Δp max [kPa]	Δp max [kPa]	Δp max [kPa]	Δp max [kPa]	Δp max [kPa]	
16	-20 ... +150		VLE122	21250100	15	0,25	20	1600	1200	1600	1600	1600	1600
			21250200	15	0,4	20	1600	1200	1600	1600	1600	1600	1600
			21250300	15	0,63	20	1600	1200	1600	1600	1600	1600	1600
			21250400	15	1,0	20	1600	1200	1600	1600	1600	1600	1600
			21250500	15	1,6	20	1600	1200	1600	1600	1600	1600	1600
			21250600	15	2,5	20	1600	1200	1600	1600	1600	1600	1600
			21250700	15	4,0	20	1600	1200	1600	1600	1600	1600	1600
			21250800	20	6,3	20	1400	970	1550	1600			1400
			21250900	25	10	20	1100	760	1250	1600			1120
			21251000	32	16	20	800	550	900	1330			810
21251100	40	25	20	570	390	640	950			580			
21251200	50	38	20	390	270	450	660			400			
16	-20 ... +150		VLE222	21252100	25	10	20	1600	1320	1600	1600		1600
			21252200	32	16	20	1600	1320	1600	1600		1600	
			21252300	40	25	20	1600	1320	1600	1600		1600	
			21252400	50	38	20	1600	1320	1600	1600		1600	
16	-20 ... +130		VLE325	21400100	20	0,63	20	1600	1200	1600	1600		1600
			21400200	20	1,0	20	1600	1200	1600	1600		1600	
			21400300	20	1,6	20	1600	1200	1600	1600		1600	
			21400400	20	2,5	20	1600	1200	1600	1600		1600	
			21400500	20	4,0	20	1600	1200	1600	1600		1600	
			21400600	25	1,0	20	1600	1200	1600	1600		1600	
			21400700	25	1,6	20	1600	1200	1600	1600		1600	
			21400800	25	2,5	20	1600	1200	1600	1600		1600	
			21400900	25	4,0	20	1600	1200	1600	1600		1600	
			21401000	32	1,6	20	1600	1200	1600	1600		1600	
			21401100	32	2,5	20	1600	1200	1600	1600		1600	
			21401200	32	4,0	20	1600	1200	1600	1600		1600	
			21401600	32	6,3	20	1600	1200	1600	1600		1600	
			21401300	40	1,6	20	1600	1200	1600	1600		1600	
21401400	40	2,5	20	1600	1200	1600	1600		1600				
21401500	40	4,0	20	1600	1200	1600	1600		1600				
21401700	40	6,3	20	1400	970	1550	1600			1400			





Δp max: Closing pressure. For further information about maximum pressure drop limits where cavitation might occur, see diagrams for each specific type of valve.

# LINEAR VALVES + ACTUATORS

## SELECTION GUIDE

			Force [N]	800	600	1000	1500	2200	900
			Stroke [mm]	52	30	60	60	60	30
			Running time [s]	15-60	15-60	15-60	15-60	60	15-300
			Actuator series	ALB	ALF				ALH
<b>ACTUATORS</b>									
Supply voltage	3-point	Proportional							
24 VAC	●	●	22050100						
24 V AC/DC	●	●		22201100	22201200	22201300	22201400		
230 VAC	●	●		22200100	22200200	22200300	22200400		
Safety function 24 V Spring return; Up ↑	●	●							† 22220100
Safety function 24 V Spring return; Down ↓	●	●							‡ 22221100



### 2-WAY VALVES

PN [bar]	T [°C]	Series	Art. No.	DN	Kvs [m <sup>3</sup> /h]	Stroke [mm]	Δp max [kPa]	Δp max [kPa]	Δp max [kPa]	Δp max [kPa]	Δp max [kPa]	Δp max [kPa]
25	-20 ... +150		VLC125	21300100	15	0,25	20	1780	1240	2030	2500	1840
			21300200	15	0,4	20	1780	1240	2030	2500	1840	
			21300300	15	0,63	20	1780	1240	2030	2500	1840	
			21300400	15	1,0	20	1780	1240	2030	2500	1840	
			21300500	15	1,6	20	1780	1240	2030	2500	1840	
			21300600	15	2,5	20	1780	1240	2030	2500	1840	
			21300700	15	4,0	20	1780	1240	2030	2500	1840	
			21300800	20	6,3	20	1410	970	1590	2360	1430	
			21301700	25	1,6	20	1080	760	1250	1860	1120	
			21301800	25	2,5	20	1080	760	1250	1860	1120	
			21301900	25	4,0	20	1080	760	1250	1860	1120	
			21302000	25	6,3	20	1080	760	1250	1860	1120	
			21300900	25	10	20	1080	760	1250	1860	1120	
			21301000	32	16	20	790	550	900	1330	810	
			21302100	40	1,6	20	560	390	640	950	580	
			21302200	40	2,5	20	560	390	640	950	580	
			21302300	40	4,0	20	560	390	640	950	580	
			21302400	40	6,3	20	560	390	640	950	580	
			21302500	40	10	20	560	390	640	950	580	
			21302600	40	16	20	560	390	640	950	580	
21301100	40	25	20	560	390	640	950	580				
21301200	50	38	20	380	270	440	660	400				
25	-20 ... +150		VLC225	21301300	25	10	20	2100	1470	2430	2500	2200
			21301400	32	16	20	2100	1470	2430	2500	2200	
			21301500	40	25	20	2100	1470	2430	2500	2200	
			21301600	50	38	20	2100	1470	2430	2500	2200	
25	-20 ... +180		VLC325	21350100	15	0,25	20	1780	1240	2030	2500	1840
			21350200	15	0,4	20	1780	1240	2030	2500	1840	
			21350300	15	0,63	20	1780	1240	2030	2500	1840	
			21350400	15	1,0	20	1780	1240	2030	2500	1840	
			21350500	15	1,6	20	1780	1240	2030	2500	1840	
			21350600	15	2,5	20	1780	1240	2030	2500	1840	
			21350700	15	4,0	20	1780	1240	2030	2500	1840	
			21350800	20	6,3	20	1410	970	1590	2360	1430	
			21350900	25	10	20	1080	760	1250	1860	1120	
			21351000	32	16	20	790	550	900	1330	810	
			21351100	40	25	20	560	390	640	950	580	
			21351200	50	38	20	380	270	440	660	400	
			25	-20 ... +180		VLC425	21351300	25	10	20	2100	1470
21351400	32	16				20	2100	1470	2430	2500	2200	
21351500	40	25				20	2100	1470	2430	2500	2200	
21351600	50	38				20	2100	1470	2430	2500	2200	





Δp max: Closing pressure. For further information about maximum pressure drop limits where cavitation might occur, see diagrams for each specific type of valve.

# LINEAR VALVES + ACTUATORS

## SELECTION GUIDE

			Force [N]	800	600	1000	1500	2200	900
			Stroke [mm]	52	30	60	60	60	30
			Running time [s]	15-60	15-60	15-60	15-60	60	15-300
			Actuator series	ALB	ALF				ALH
<b>ACTUATORS</b>									
Supply voltage	3-point	Proportional							
24 VAC	●	●	22050100						
24 V AC/DC	●	●		22201100	22201200	22201300	22201400		
230 VAC	●	●		22200100	22200200	22200300	22200400		
Safety function 24 V Spring return; Up ↑	●	●							† 22220100
Safety function 24 V Spring return; Down ↓	●	●							‡ 22221100

### 3-WAY VALVES

PN [bar]	T [°C]	Series	Art. No.	DN	Kvs [m <sup>3</sup> /h]	Stroke [mm]	Δp max [kPa]	Δp max [kPa]	Δp max [kPa]	Δp max [kPa]	Δp max [kPa]	Δp max [kPa]	
6	-20 ... +120		VLF135	21000900	15	1,6	20	600	600	600			600
			21001000	15	2,5	20	600	600	600			600	
			21001100	15	4,0	20	600	600	600			600	
			21001200	20	6,3	20	600	600	600			600	
			21001300	25	10	20	600	600	600			600	
			21001400	32	16	20	600	600	600			600	
			21001500	40	25	20	570	570	600			600	
			21001600	50	38	20	390	270	450			400	
16	-20 ... +130		VLA335	21200900	15	1,6	20	1600	1200	1600	1600		1600
			21201000	15	2,5	20	1600	1200	1600	1600		1600	
			21201100	15	4,0	20	1600	1200	1600	1600		1600	
			21201200	20	6,3	20	1400	970	1550	1600		1400	
			21201300	25	10	20	1100	760	1250	1600		1120	
			21201400	32	16	20	800	550	900	1330		810	
			21201500	40	25	20	570	390	640	950		580	
			21201600	50	38	20	390	270	450	660		400	
16	-10 ... +150		VLB335	21221100	65	63	25	180		310	480	710	180
			21221200	80	100	45	110		200	310	460		
			21221300	100	130	45	70		120	190	280		
			21221400	125	200	45	40		70	120	180		
			21221500	150	300	45	30		50	80	120		
16	-20 ... +130		VLA131	21150900	15	1,6	20	1600	1200	1600	1600		1600
			21151000	15	2,5	20	1600	1200	1600	1600		1600	
			21151100	15	4,0	20	1600	1200	1600	1600		1600	
			21151200	20	6,3	20	1400	970	1550	1600		1400	
			21151300	25	10	20	1100	760	1250	1600		1120	
			21151400	32	16	20	800	550	900	1330		810	
			21151500	40	25	20	570	390	640	950		580	
			21151600	50	38	20	390	270	450	660		400	
16	-20 ... +150		VLE132	21251300	15	1,6	20	1600	1200	1600	1600		1600
			21251400	15	2,5	20	1600	1200	1600	1600		1600	
			21251500	15	4,0	20	1600	1200	1600	1600		1600	
			21251600	20	6,3	20	1400	970	1550	1600		1400	
			21251700	25	10	20	1100	760	1250	1600		1120	
			21251800	32	16	20	800	550	900	1330		810	
			21251900	40	25	20	570	390	640	950		580	
			21252000	50	38	20	390	270	450	660		400	

Δp max: Closing pressure. For further information about maximum pressure drop limits where cavitation might occur, see diagrams for each specific type of valve.

# LINEAR VALVES DIMENSIONING

## FLOW CHART

To be considered: As both the viscosity and the thermal conduction are affected when glycol is added to the system water, this fact has to be considered when dimensioning the valve.

A good rule is to choose one size higher Kv-value when 30 – 50% glycol is added. A lower concentration of glycol may be disregarded.

N.B.! Maximum 50% glycol for freezing protection and oxygen absorbing compounds are allowed as additives.

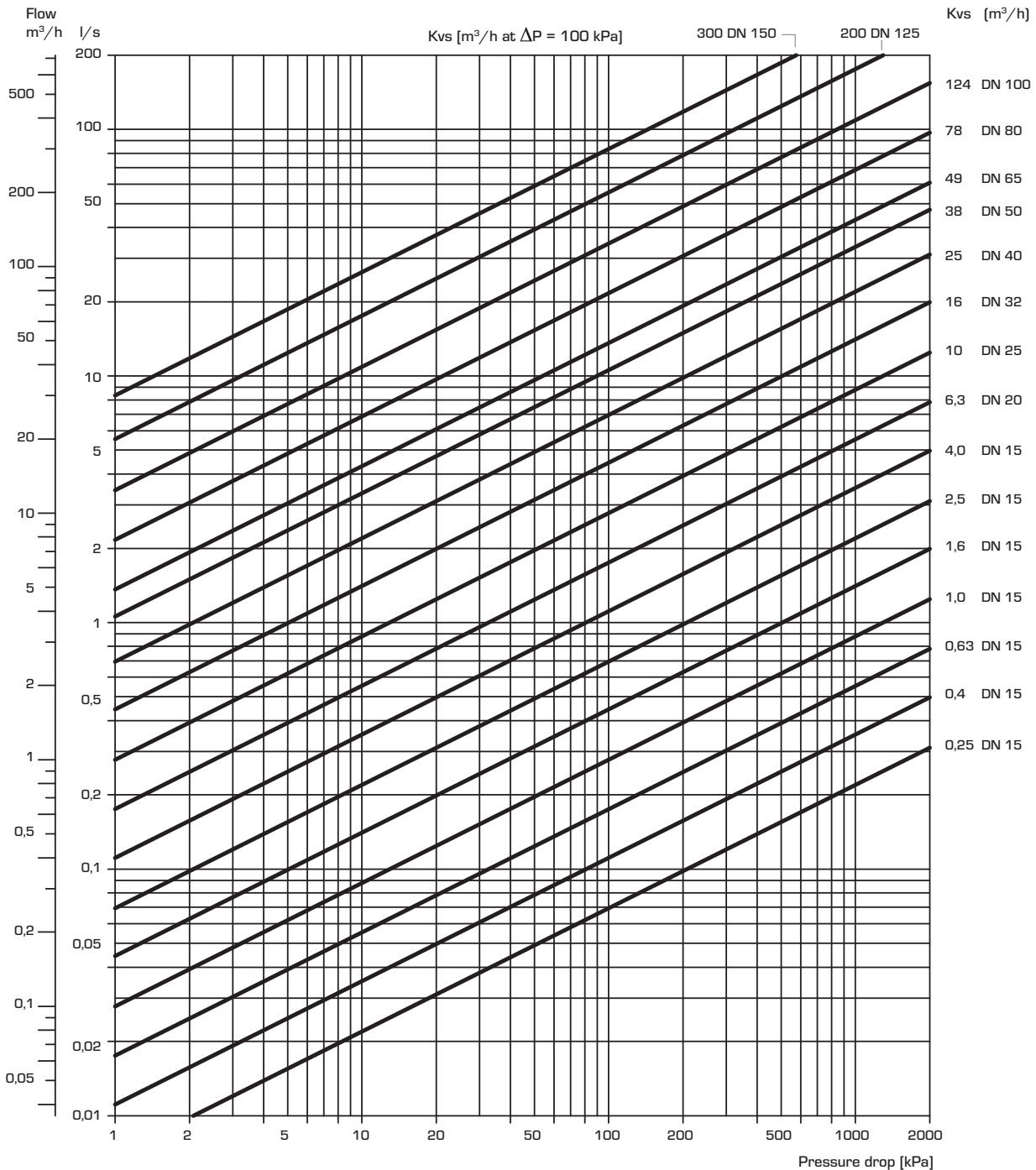

# LINEAR VALVES

## VALVE CHARACTERISTICS

### SERIES VLF125 & VLF135

2-way valves, DN15-50

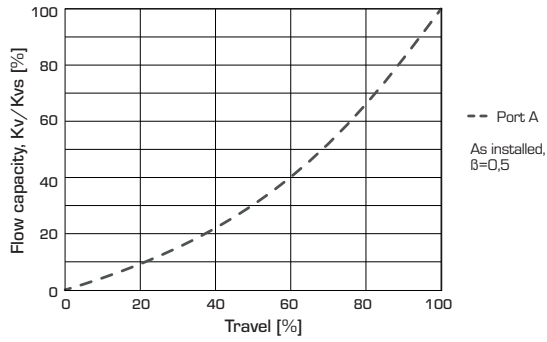

3-way valves, DN15-50

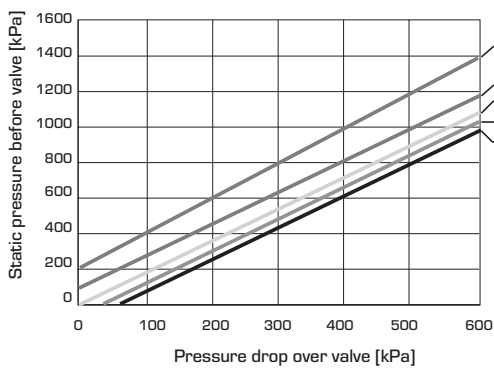
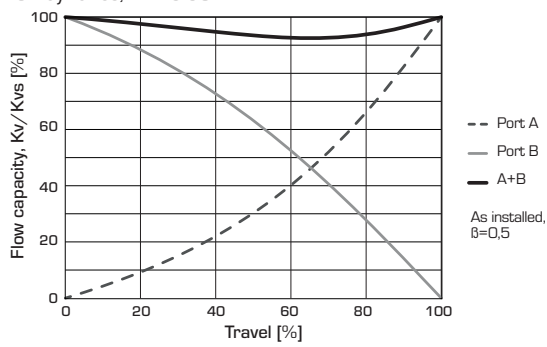

Pressure drop limit where cavitation might occur. Is dependent of valve inlet pressure and temperature of water.

### SERIES VLA100

2-way valves, DN15-50

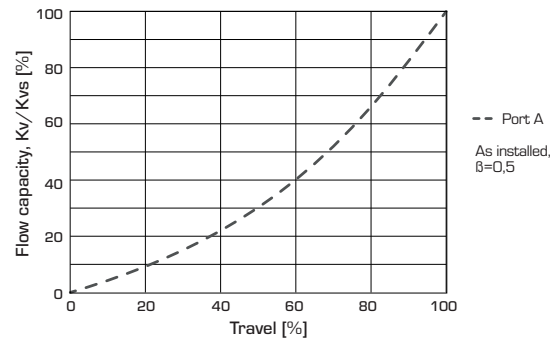

3-way valves, DN15-50

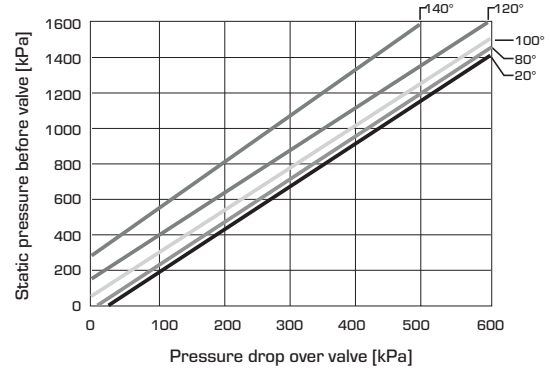
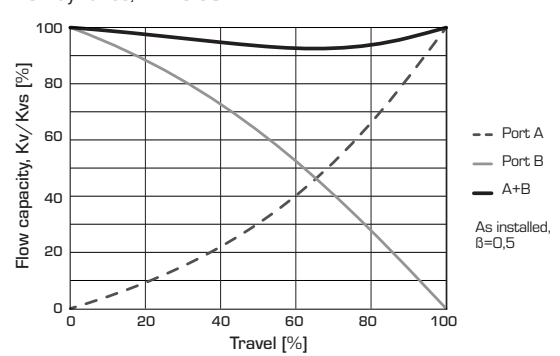

Pressure drop limit where cavitation might occur. Is dependent of valve inlet pressure and temperature of water.



# LINEAR VALVES

## VALVE CHARACTERISTICS

### SERIES VLA300 & VLB300

2-way valves, DN15-50

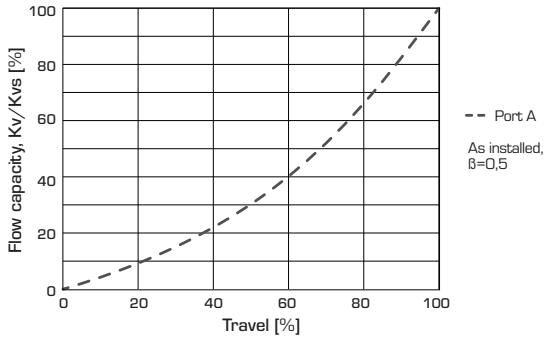

3-way valves, DN15-50

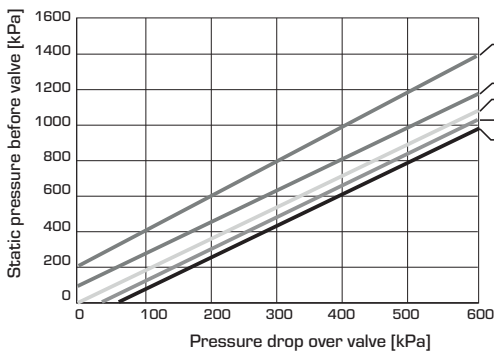
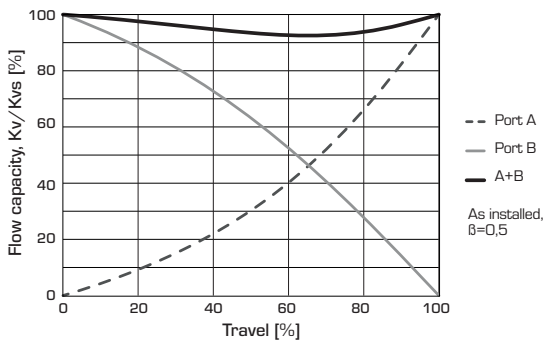

Pressure drop limit where cavitation might occur. Is dependent of valve inlet pressure and temperature of water.

### SERIES VLE100 & VLE200

2-way valves, DN15-50

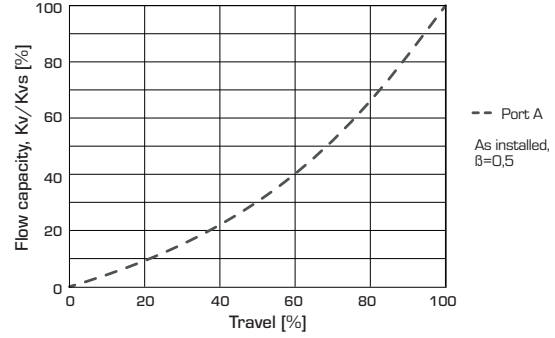

3-way valves, DN15-50

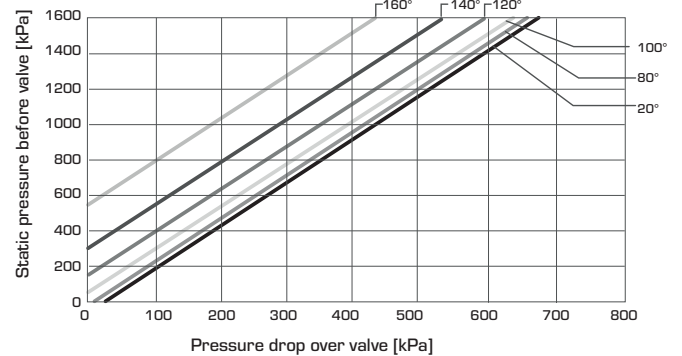
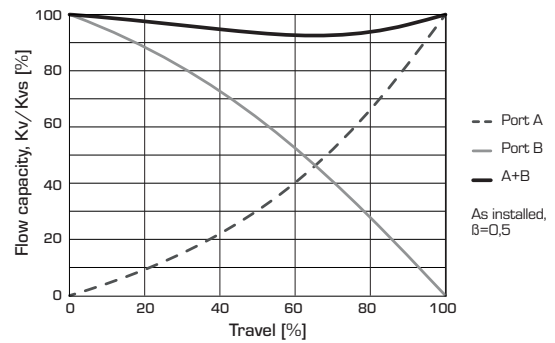

Pressure drop limit where cavitation might occur. Is dependent of valve inlet pressure and temperature of water.

# LINEAR VALVES

## VALVE CHARACTERISTICS

### SERIES VLB300

2-way valves, DN65-150

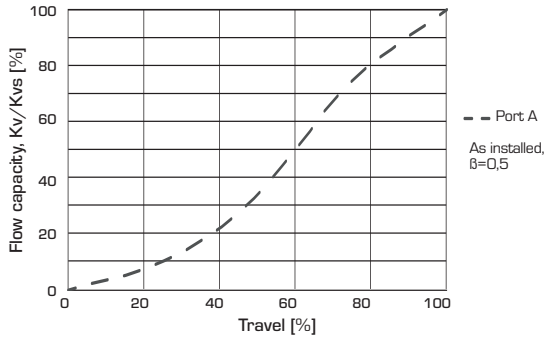

3-way valves, DN65-150

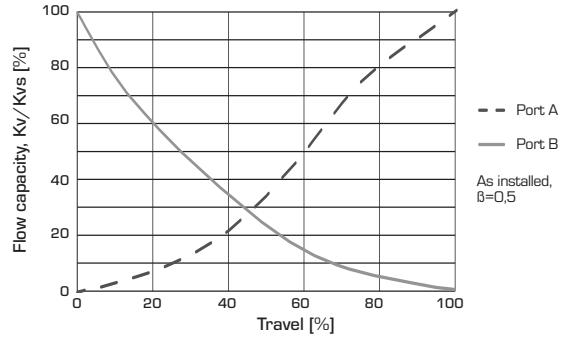

### SERIES VLE300

2-way valves, DN15-50

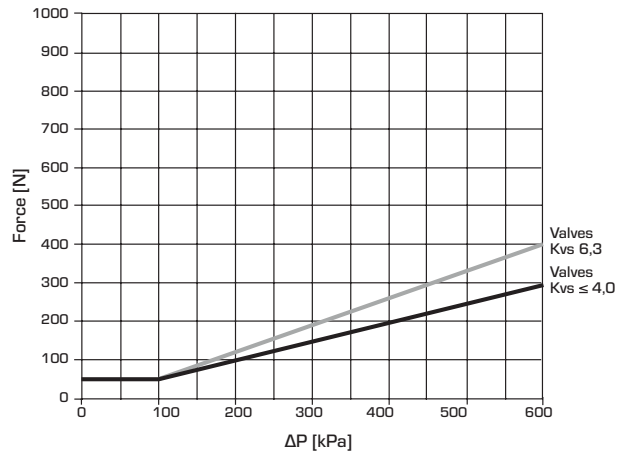
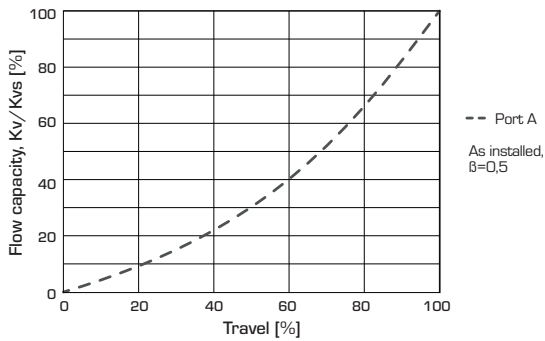

Required clamping force of the control unit for tightness 0,02% of Kvs.

### SERIES VLC100 & 200

2-way valves, DN15-50

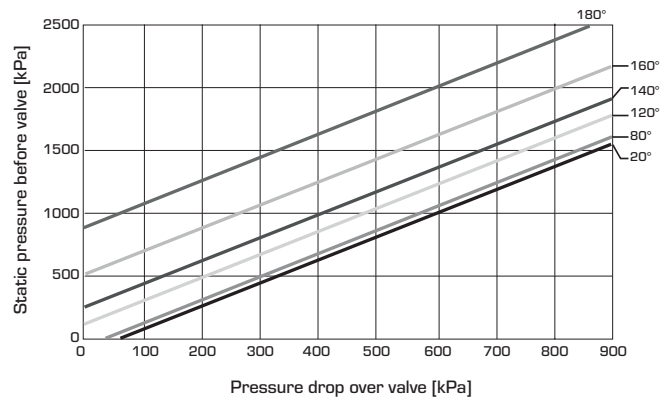
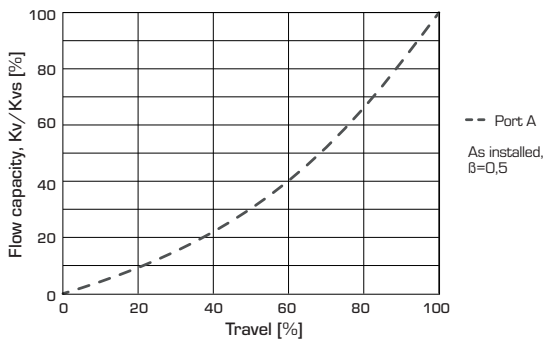

Pressure drop limit where cavitation might occur. Is dependent of valve inlet pressure and temperature of water.

# LINEAR VALVES + ACTUATORS INSTALLATION EXAMPLES

## INSTALLATION

The valve should be mounted with flow direction in accordance with the valve marking.

If possible, the valve should be installed in the return pipe, in order to avoid exposing the actuator to high temperatures.

The valve must not be installed with the actuator mounted below the valve.

### Mounting positions:

A = Allowed mounting position with fluid temperature between  $-20^{\circ}\text{C}$  to  $+120^{\circ}\text{C}$ .

B = Allowed mounting position with fluid temperature between  $0^{\circ}\text{C}$  to  $+150^{\circ}\text{C}$ .

C = Not allowed mounting position.

To ensure that suspended solids will not become jammed between the valve plug and seat, a filter should be installed upstream of the valve, and the pipe system should be flushed before the valve is installed.

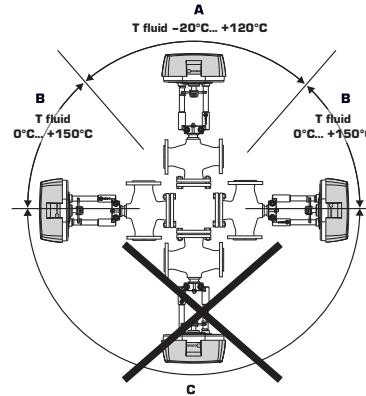

## VALVE AUTHORITY [ $\beta$ ]

$\Delta p_v$  - pressure losses over the valve [bar]

$\Delta p_{sys}$  - pressure losses over the system with variable flow [bar]

$\Delta p_{inst}$  - pressure losses over the installation [bar]

Recommendation : Valve authority [ $\beta$ ] shall be between 0,3 to 0,7

a) 2-way valve

$$\beta = \frac{\Delta p_v}{\Delta p_v + \Delta p_{inst}}$$

b) 3-way valve

$$\beta = \frac{\Delta p_v}{\Delta p_v + \Delta p_{sys}}$$

## 2-WAY CONTROL VALVES, EXAMPLE A-B

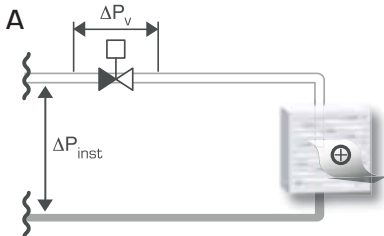

Installation without local circulating pump

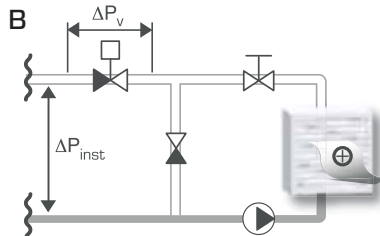

Installation with local circulating pump

## 3-WAY CONTROL VALVES, EXAMPLE C-E

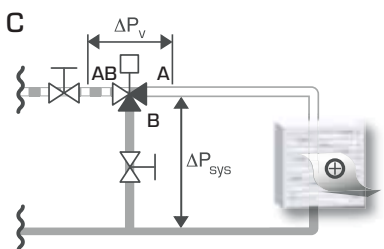

Circuit without local circulation pump

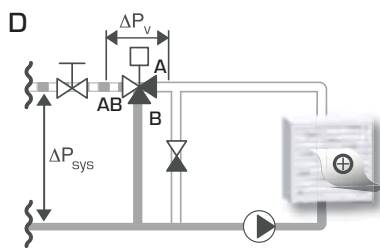

Circuit with local circulation pump

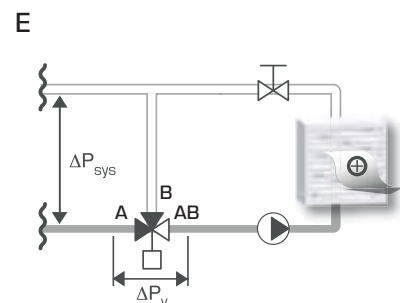

Circuit with local circulating pump

# LINEAR ACTUATORS FAST IN. FAST OUT. JOB WELL DONE.

**Reliable valves and actuators** for energy-efficient regulation in heating and cooling systems. And don't forget. The products are easy to use and install.



#### Legend

**3-P** 3-point SPDT = Single Pole Double Throw

**Prop.** Proportional = 0..10 V, 2..10 V, 0..20mA, 4..20mA





**ACTUATOR**  
Series ALFxx1, ALFxx4

- Actuator is available with both 3-point floating control mode and modulating / proportional control mode
- Position feedback signal (only available in modulating / proportional control mode)
- Fast running time

Series ALFxx1 is a range of 230V version linear actuators available with 3-point floating control mode (extend/retract) and modulating / proportional control mode (voltage/current). The series is available with different levels of force and stroke possibilities

Series ALFxx4 is a range of 24V version linear actuators available with 3-point floating control mode (extend/retract) and modulating / proportional control mode (voltage/current). The series is available with different levels of force and stroke possibilities

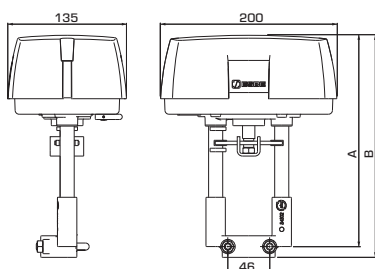

**TECHNICAL DATA**

Supply voltage ALFxx1: \_\_\_\_\_ 230 VAC ±10%, 50/60 Hz  
 Supply voltage ALFxx4: \_\_\_\_\_ 24 VAC ±20%, 50/60 Hz  
 \_\_\_\_\_ 24 VDC (22-30 VDC)  
 Power consumption: \_\_\_\_\_ see table  
 Stroke: \_\_\_\_\_ 5..30 / 5..60 mm  
 Force: \_\_\_\_\_ 600 - 2200 N  
 Duty cycle: \_\_\_\_\_ max. 50%/h  
 Ambient temperature: \_\_\_\_\_ -10°C - +50°C +  
 Ambient humidity: \_\_\_\_\_ max. 90% RH  
 Enclosure rating: \_\_\_\_\_ IP 54  
 Feedback signal, "U": \_\_\_\_\_ 2 - 10 VDC (0 - 100%)  
 Modulating / proportional control signal, "Y":  
 \_\_\_\_\_ 0 - 10 VDC, 2 - 10 VDC  
 \_\_\_\_\_ 0 - 5 VDC, 5 - 10 VDC  
 \_\_\_\_\_ 2 - 6 VDC, 6 - 10 VDC  
 \_\_\_\_\_ 4 - 20mA  
 Running time by modulating/proportional signal  
 600, 1000, 1500 N version:  
 Valve with stroke between 5 - 15 mm: \_\_\_\_\_ 15 s  
 Valve with stroke between 16 - 25 mm: \_\_\_\_\_ 20 s  
 Valve with stroke between 26 - 60 mm: \_\_\_\_\_ 30 s  
 2200 N version:  
 Valve with stroke between 5 - 60 mm: \_\_\_\_\_ 60 s  
 3-point floating operating voltage ALFxx1 : \_\_\_\_\_ 230 VAC  
 3-point floating operating voltage ALFxx4 (source): \_\_\_\_\_ 24 VAC  
 3-point floating operating voltage ALFxx4 (sink): \_\_\_\_\_ 24 V AC/DC  
 Running time by floating control signal: \_\_\_\_\_ 60 s  
 Weight: \_\_\_\_\_ 1,5 kg  
 Material  
 Cover: \_\_\_\_\_ Plastic  
 Housing: \_\_\_\_\_ Aluminum

\* If the actuator is used in applications with media temperatures below 0°C, the valve should be equipped with a stem heater.

CE LVD 2014/35/EU - EMC 2014/30/EU - RoHS 2011/65/EU

**ALFxx1** Modulating/proportional or 3-point floating control signal, power supply 230V AC

Art. No.	Reference	Supply voltage [V]	Force [N]	Stroke [mm]	Power consumption		A	B	Note
					Running	Holding			
22200100	ALF131	230V AC, 50Hz	600	30	13VA/6W	11VA/5W	216	228	
22200200	ALF261		1000	60	18VA/8W	11VA/5W	240	252	
22200300	ALF361		1500		21VA/11W	13VA/7W			
22200400	ALF461		2200		25VA/10W	25VA/4W			

**ALFxx4** Modulating/proportional or 3-point floating control signal, power supply 24V AC/DC

Art. No.	Reference	Supply voltage [V]	Force [N]	Stroke [mm]	Power consumption		A	B	Note
					Running	Holding			
22201100	ALF134	24V AC/DC	600	30	13VA/6W	11VA/5W	216	228	
22201200	ALF264		1000	60	18VA/8W	11VA/5W	240	252	
22201300	ALF364		1500		21VA/11W	13VA/7W			
22201400	ALF464		2200		25VA/10W	25VA/4W			



**ADDITIONAL GUIDANCE**

Accessories.....165

For further detailed information ..... www.esbe.eu



## ACTUATOR Series ALHx00

- Can be used with both 3-point or proportional control signal
- Fail-safe spring return functionality
- Position feedback signal
- Perfect match with ESBE valves

Series ALHxx4 is a range of 24V linear spring return actuators available with 3-point floating control mode (extend/retract) and proportional control mode (voltage/current). The series is available with different stem spring return directions (up/down).

### TECHNICAL DATA

Supply voltage: \_\_\_\_\_ 24V AC/DC ± 20%, 50/60 Hz  
 Power consumption: \_\_\_\_\_ see table  
 Transformer size: \_\_\_\_\_ 50 VA  
 Stroke: \_\_\_\_\_ 9-30 mm  
 Force: \_\_\_\_\_ 900 N  
 Duty cycle -  
     full load, high ambient temperature: \_\_\_\_\_ max. 20%/60 minutes  
     half load, room temperature: \_\_\_\_\_ 80%/60 minutes  
 Output Y, Voltage: \_\_\_\_\_ 2-10 or 0-5V DC (0-100%)  
     - Load 2 mA  
 Ambient temperature: \_\_\_\_\_ -10°C - +50°C \*  
 Ambient humidity: \_\_\_\_\_ max. 90% RH  
 Enclosure rating: \_\_\_\_\_ IP 54  
 Modulating control signal: \_\_\_\_\_ 0-10V DC, 2-10V DC  
     \_\_\_\_\_ 0-5V DC, 5-10V DC  
     \_\_\_\_\_ 2-6V DC, 6-10V DC  
 Running time by modulating/proportional signal,  
     Valve with stroke 9-25 mm: \_\_\_\_\_ 15 s  
     Valve with stroke 26-30mm: \_\_\_\_\_ 20 s  
 Running time by 3-point floating control signal: \_\_\_\_\_ 60 s/300 s  
 Running time spring return,  
     Valve with stroke 9-25 mm: \_\_\_\_\_ 13 s  
     Valve with stroke 26-30 mm: \_\_\_\_\_ 18 s  
 Weight: \_\_\_\_\_ 2,8 kg

Material  
 Cover: \_\_\_\_\_ ABS Plastic  
 Housing: \_\_\_\_\_ Aluminum  
 \* If the actuator is used in applications with media temperatures below 0°C, the valve should be equipped with a stem heater.

CE LVD 2014/35/EU - EMC 2014/30/EU - RoHS 2011/65/EU

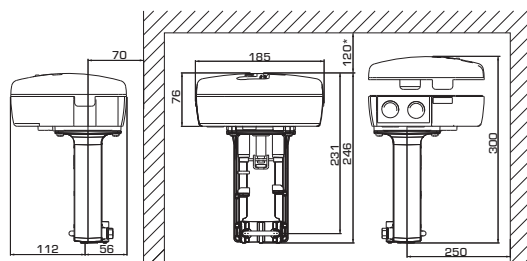

Art. No.	Reference	Supply voltage [V]	Force [N]	Stroke [mm]	Power consumption,		Note
					Running [W]	Holding [W]	
22220100	ALH134	24V AC/DC, 50/60Hz	900	30	21	7	Spring return stem direction up
22221100	ALH234						Spring return stem direction down



### ADDITIONAL GUIDANCE

Accessories.....165 For further detailed information ..... [www.esbe.eu](http://www.esbe.eu)

Notes: \* Minimum distance needed for manual override operation.



3-P  
 Prop.

**ACTUATOR**  
 Series ALB100

- **Fast running time**
- **Can be used for both 3-point and proportional control signal**
- **Position feedback signal**
- **Perfect match between the actuator and ESBE valve**

Series ALB100 with voltage proportional or 3-point (open / close) signal is a actuator with fast running time and large available force. The electronic circuitry ensure that the working range is automatically adjusted and that the running time is the same, regardless of the stroke of the valve.

**TECHNICAL DATA**

Supply voltage: \_\_\_\_\_ 24 VAC ±10%, 50/60 Hz  
 Power consumption: \_\_\_\_\_ 15 VA  
 Running time by proportional signal,  
     Valve with stroke 10–25 mm: \_\_\_\_\_ 15 s  
     Valve with stroke 10–32 mm: \_\_\_\_\_ 20 s  
     Valve with stroke 10–52 mm: \_\_\_\_\_ 30 s  
 Running time by increase/decrease signal: \_\_\_\_\_ 300 s/60 s  
 Stroke: \_\_\_\_\_ 10–52 mm  
 Force: \_\_\_\_\_ 800 N  
 Duty cycle: \_\_\_\_\_ max. 20%/h  
 Output Y, Voltage: \_\_\_\_\_ 2–10 V (0–100%)  
 Ambient temperature: \_\_\_\_\_ -10°C – +50°C \*  
 Ambient humidity: \_\_\_\_\_ max. 90% RH  
 Enclosure rating: \_\_\_\_\_ IP 54

Material  
 Cover: \_\_\_\_\_ Plastic / Metal  
 Housing: \_\_\_\_\_ Aluminum  
 Weight: \_\_\_\_\_ 1,8 kg

\* If the actuator is used in applications with media temperatures below 0°C, the valve should be equipped with a stem heater.

CE LVD 2014/35/EU - EMC 2014/30/EU - RoHS 2011/65/EU

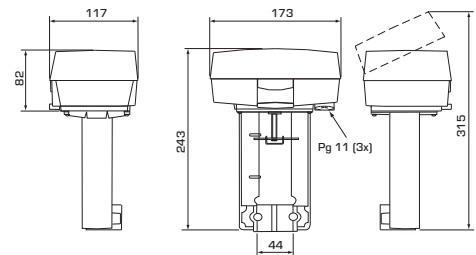

Art. No.	Reference	Supply voltage [V]	Force [N]	Power consumption [VA]	Note
22050100	ALB144	24 V AC, 50/60Hz	800	15,0	1)



**ADDITIONAL GUIDANCE**

Accessories.....165

For further detailed information ..... [www.esbe.eu](http://www.esbe.eu)

Notes: 1) 0...10V, 2...10V or 3-point control signal



## ADAPTOR KITS

Options ESBE actuators to other valves

Art. No.	Ref.	Actuator					Designation	Note
		ALA*	ALB	ALF13x	ALF26x, ALF36x, ALF46x	ALHxxx		
26000400	ALA823	●	●	●	●	●	Danfoss VF2, VF3, VL2, VL3, VRG3, VRB2, VRB3	
26001000	ALA827	●	●	●	●	●	Honeywell V5011R, V5013R, V538, V5049A, V5050A, V5328A, V5329A, V5329C, V5095A, V176, V5015	
26001100	ALA827	●	●	●	●	●	Osby/Regin MTV/MTVS, MTR/MTRS, 2SA/2SB, FRS, GTR/RTV/BTRV, GTVS/RTVS, GTRS/RTRS	
26000800	ALA826	●	●	●	●	●	Satchwell VZ, VJF, VSF 15-50, VZF, MZF 65-150	
26000500	ALA824	●	●	●	●	●	Sauter B6F, B6G, B6R, B6S, BXD, BXE, V6F, V6G, V6R, V6S, VXD, VXE	
26000100	ALA821	●		●			Siemens – with stroke 20 mm – WVF31..., WVF32..., WVF40... WVF41..., WVF42..., WVF42..K, WVF52..., WVF53..., WVG41..., VXF31..., VXF32..., VXF40..., VXF41..., VXF42..., VXF53..., VVG41..	
26000200	ALB841		●		●	●	Siemens WVF31..., WVF32..., WVF40... WVF41..., WVF42..., WVF42..K, WVF43..., WVF45..., WVG41..., WVF52..., WVF53..., WVF61..., VXF31..., VXF32..., VXF40..., VXF41..., VXF42..., VXF43..., VXF53..., VXF61..., VVG41..	

## STEM HEATER



Options actuators

Art. No.	Reference	For	Operating voltage	Note
26201200	ALF802	ALHxxx, ALFxxx, ALBxxx, ALAxxx*	24V AC/DC	

## END POSITION CONTACTS



Options actuators

Art. No.	Reference	For	Switching capabilities	Note
26200700	ALB841	ALBxxx	4A @ 24V AC/DC	
26201100	ALF801	ALFxxx	4A @ 24V AC/DC	

## ADAPTOR KITS



Options ESBE valves DN65–150 to ESBE actuators

Art. No.	Ref.	For	Adaptor kit to	Note
26001200	VLB891	ESBE VLB300	ESBE ALD14x, ALD24x	

Options ESBE valves DN15–50 to other actuators

Art. No.	Ref.	For	Adaptor kit to	Note
26000700	VLA821	ESBE VLx	Siemens SQX, SAX	

Notes: \*Actuator series ALA has expired from assortment and is replaced by series ALF

ESBE CATALOGUE • EN • A  
Valid from 01.06.2018

© Copyright. Rights reserved to make alterations.

# COMPLEMENTARY PRODUCTS SOMETIMES THE REALLY IMPORTANT ONES

**Our complementary might** often be small components, but sometimes real important ones, that complete the installation of the pipeline systems.



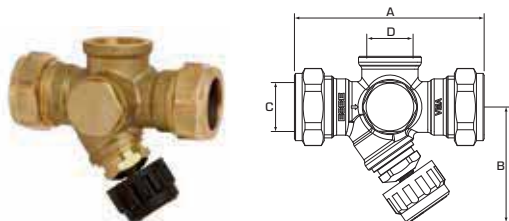

## MANIFOLD Series VMA200

- Built-in shut-off and check valve functions
- Connections for safety and maintenance equipment
- Complying with EN1717

Manifolds series VMA200 are inlet valves in domestic hot water systems. The manifolds are equipped with connections for safety valve, draining valve, filling valve and vacuum valve for protection and maintenance of installations.

### TECHNICAL DATA

Pressure class: \_\_\_\_\_ PN 16  
 Max. working temperature: \_\_\_\_\_ 100°C  
 Connection: \_\_\_\_\_ Internal thread (G), ISO 228/1  
 \_\_\_\_\_ Compression fitting (CPF), EN 1254-2

Material  
 Valve housing and other metal parts with fluid contact: \_\_\_\_\_ Dezincification resistant brass, DZR\*  
 Seat seal: \_\_\_\_\_ EPDM  
 O-rings: \_\_\_\_\_ EPDM  
 Knob: \_\_\_\_\_ Plastic  
 Regulating cone: \_\_\_\_\_ Plastic (PPA)

\* Suitable for drinking water applications

PED 2014/68/EU, article 4.3

### VMA213 Compression Fitting/internal thread

Art. No.	Reference	DN	Kvs	Connection		Dimension		Weight [kg]	Note
				C	D	A	B		
36401000	VMA213	15	2,5	CPF 15 mm	G 1/2"	86	53	0,30	
36401100		20	3,5	CPF 22 mm				0,35	

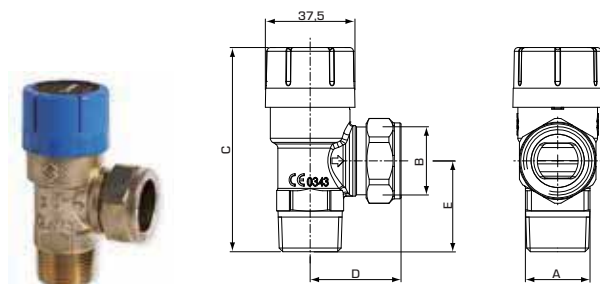

## SAFETY VALVE Series VSB100

- Available with opening pressure from 6 to 10 bar
- For temperatures up to 95°C
- Fits perfectly on series VMA200/VMB400
- Approved by TÜV and ACS

Safety valves series VSB100 are used to secure domestic hot water systems against excess pressure.

### TECHNICAL DATA

Pressure class: \_\_\_\_\_ PN 16  
 Temperature: \_\_\_\_\_ max. 95°C  
 \_\_\_\_\_ min. 0°C  
 Connection: \_\_\_\_\_ External thread (R), EN 10226-1  
 \_\_\_\_\_ Compression fitting (CPF), EN 1254-2

Material  
 Valve housing and other metal parts with fluid contact: \_\_\_\_\_ Dezincification resistant brass, DZR\*

\* Suitable for drinking water applications

CE PED 2014/68/EU TÜV TÜV ACS

### VSB132 External thread and Compression fitting

Art. No.	Reference	Opening pressure		Blow-off capacity*		DN	Connection		Dimension			Weight [kg]	Note
		[MPa]	[bar]	[kW] <sup>1)</sup>	[l/h] <sup>2)</sup>		A	B	C	D	E		
36020100	VSB132	0,6	6,0	75	76	15	R 1/2"	CPF 15 mm	81,2	40,5	34,0	0,18	1), 2)
36020300		0,8	8,0										
36020400		0,9	9,0										
36020500		1,0	10,0										

FOR MORE VERSIONS .....WWW.ESBE.EU

Safety valve - Notes: \* given at specified pressure +20% 1) Acc. to EN-1491 § 9 2) Acc. to EN-1491 § 6.2.4

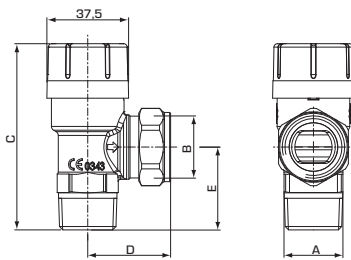

## SAFETY VALVE Series VSB200

- For temperatures up to 120°C
- Approved by TÜV

Safety valves series VSB200 are used to secure heating systems against excess pressure.

### TECHNICAL DATA

Pressure class: \_\_\_\_\_ PN 16  
 Temperature: \_\_\_\_\_ max. 120°C  
 \_\_\_\_\_ min. -10°C  
 Connection: \_\_\_\_\_ External thread (R), ISO 7/1  
 \_\_\_\_\_ Compression fitting (CPF), EN 1254-2  
 Media: \_\_\_\_\_ Heating water (in accordance with VDI2035)  
 \_\_\_\_\_ Water / Glycol mixtures, max. 50%  
 (above 20% admixture, the pumping data must be checked)  
 \_\_\_\_\_ Water / Ethanol mixtures, max. 28%

Material  
 Valve housing and other metal parts with fluid contact: \_\_\_\_\_ Brass CW 617N

CE PED 2014/68/EU TÜV

### VSB232 External thread and Compression fitting

Art. No.	Reference	Opening pressure		Blow-off capacity*		DN	Connection		Dimension			Weight [kg]	Note
		[MPa]	[bar]	[kW] <sup>1)</sup>	[l/h] <sup>2)</sup>		A	B	C	D	E		
36023500	VSB232	0,15	1,5	105	175	20	R 3/4"	CPF 22 mm	85,4	40,5	38,0	0,20	

FOR MORE VERSIONS ..... WWW.ESBE.EU

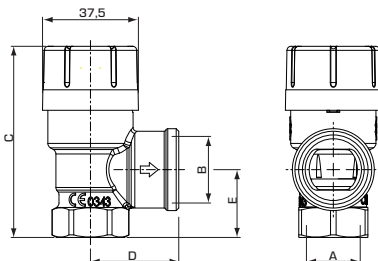

## SAFETY VALVE Series VSB300

- For temperatures up to 160°C
- Approved by TÜV

Safety valves series VSB300 are used to secure solar heating systems against excess pressure.

### TECHNICAL DATA

Pressure class: \_\_\_\_\_ PN 16  
 Temperature: \_\_\_\_\_ max. (continuously) +120°C  
 \_\_\_\_\_ max. (temporarily) +160°C  
 \_\_\_\_\_ min. -10°C  
 Connection: \_\_\_\_\_ Internal thread (G), ISO 228/1  
 \_\_\_\_\_ Internal thread (Rp), EN 10226-1  
 Media: \_\_\_\_\_ Heating water (in accordance with VDI2035)  
 \_\_\_\_\_ Water / Glycol mixtures, max. 50%  
 (above 20% admixture, the pumping data must be checked)

Material  
 Valve housing and other metal parts with fluid contact: \_\_\_\_\_ Brass CW 617N

CE PED 2014/68/EU TÜV

### VSB311 Internal thread

Art. No.	Reference	Opening pressure		Blow-off capacity*		DN	Connection		Dimension			Weight [kg]	Note
		[MPa]	[bar]	[kW] <sup>3)</sup>	[a <sub>w</sub> ] <sup>4)</sup>		A	B	C	D	E		
36025000	VSB311	0,35	3,5	50	0,58	15	G 1/2"	Rp 3/4"	74,7	34,5	26,5	0,16	

FOR MORE VERSIONS ..... WWW.ESBE.EU

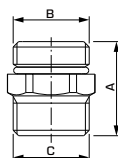

## DRAINING VALVE Series VDA100

- Available with external thread connection or by hose nipple

Draining valves series VDA100 for boilers, hot water tanks, pipes etc. Draining valves series VDA100 are opened by connecting a hose nipple. The spring-loaded plug is then moved to open position.

### TECHNICAL DATA

Pressure class: \_\_\_\_\_ PN 16  
 Max. working temperature: \_\_\_\_\_ 90°C  
 Connections: \_\_\_\_\_ External thread (G), ISO 228/1

Material  
 Valve housing and other metal parts with fluid contact: \_\_\_\_\_ Dezincification resistant brass, DZR\*  
 Plug: \_\_\_\_\_ Plastic  
 O-rings: \_\_\_\_\_ EPDM

\* Suitable for drinking water applications

PED 2014/68/EU, article 4.3

### VDA102 External thread

Art. No.	Reference	DN	Dimension		Connection		Cover	Weight [kg]	Note
			A	B	C	C			
36200100	VDA102	15	26	G 1/2"	G 1/2"	Brass	0,06		

Safety valve - Notes: \* given at specified pressure +20% 1) Measurements by supplier 2) Acc. to EN-1489 § 6.2.4 3) Acc. to TRD 721 § 7.2.4.2 4) Acc. to TRD 721 § 6.2.5

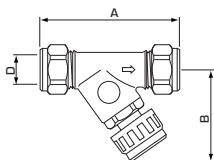

## FILLING VALVE

### Series VFA100

- Available with built-in shut-off and check valve functions

Filling valves series VFA100 for the filling of heating system and other closed fluid systems.

#### TECHNICAL DATA

Pressure class: \_\_\_\_\_ PN 16  
 Max. working temperature: \_\_\_\_\_ 100°C  
 Connections: \_\_\_\_\_ Compression fitting (CPF), EN 1254-2

#### Material

Valve housing and other metal parts with fluid contact:

\_\_\_\_\_ Dezinification resistant brass, DZR\*

Seat seal: \_\_\_\_\_ Silicone

O-rings: \_\_\_\_\_ EPDM

Knob: \_\_\_\_\_ Plastic

\* Suitable for drinking water applications

PED 2014/68/EU, article 4.3

### VFA103 Compression fitting

Art. No.	Reference	DN	Kvs	Dimension		Connection	Weight [kg]	Note
				A	B			
36300100	VFA103	15	2	75	58	CPF 15 mm	0,21	

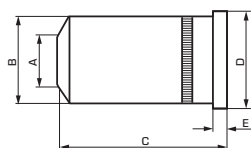

## CHECK VALVE

### Series VCA100

- Lowest possible pressure drop
- Low opening pressure

Check valves series VCA100, check valves for internal use in pipes the check valves are designed for lowest possible pressure drop combined with a low opening pressure.

#### TECHNICAL DATA

Max. working temperature: \_\_\_\_\_ 110°C

#### Material

Body - DN15: \_\_\_\_\_ Dezinification resistant brass, DZR\*

- DN 20: \_\_\_\_\_ Dezinification resistant brass, DZR\*/Copper

Plug: \_\_\_\_\_ Dezinification resistant brass, DZR\*

Spring resort: \_\_\_\_\_ Plastic

Spring: \_\_\_\_\_ Stainless steel

O-ring: \_\_\_\_\_ EPDM

\* Suitable for drinking water applications

Art. No.	Reference	DN	Kvs	Dimension					Opening pressure [kPa]	Weight [kg]	Note		
				A	B	C	D	E				↑	→
36500100	VCA100	15	1,5	8,0	12,8	27,0	14,5	2,0	4,0	3,8	3,5	0,01	
36500400		20	4,0	12,0	19,8	30,0	21,5		2,5	2,3	2,0	0,02	

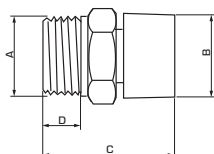

## VACUUM VALVE

### Series VVA100

- Protecting water heaters from under pressure and siphonage
- Fits perfectly on series VMA200/VMB400

Vacuum valves series VVA100, intended as anti-siphonage devices.

#### TECHNICAL DATA

Pressure class: \_\_\_\_\_ PN 10

Max. working temperature: \_\_\_\_\_ 90°C

Connection: \_\_\_\_\_ External thread (G), ISO 228/1

#### Material

Body: \_\_\_\_\_ Dezinification resistant brass, DZR\*

Plug: \_\_\_\_\_ Plastic

Spring: \_\_\_\_\_ Stainless steel

O-ring: \_\_\_\_\_ EPDM

\* Suitable for drinking water applications

PED 2014/68/EU, article 4.3

Art. No.	Reference	DN	Connection	Dimension				Weight [kg]	Note
				A	B	C	D		
36100100	VVA102	15	G 1/2"	22,0	33,0	9,0	0,03		



## IMMERSION ADJUSTABLE THERMOSTAT Series TIA100

- **Easy installation**
- **External temperature setting 0-90°C**
- **100 or 200 mm Immersion sleeve length**

The ESBE TIA100 is a ON/OFF thermostat, consisting of temperature probe connected to a switch. The switch can be used to control ON/OFF, based on the temperature measurement, any electrical device e.g. pump, boiler, etc.

### TECHNICAL DATA

Contacts rating: \_\_\_\_\_ (C-1) 10(2,5)A NC/250V~  
 \_\_\_\_\_ (C-2) 6(2,5)A NC/250V~  
 Enclosure rating: \_\_\_\_\_ IP40  
 Control range: \_\_\_\_\_ 0 ± 5°C - 90 ± 3°C  
 Maximum ambient temperature: \_\_\_\_\_ 80°C  
 Maximum bulb temperature: \_\_\_\_\_ 125°C  
 Temperature differential: \_\_\_\_\_ ΔT 4 ± 1K

Material  
 Cover: \_\_\_\_\_ Plastic  
 Sensor: \_\_\_\_\_ Copper

CE LVD 2014/35/EU - RoHS 2011/65/EU  
 PED 2014/68/EU, Annex III - Module H1

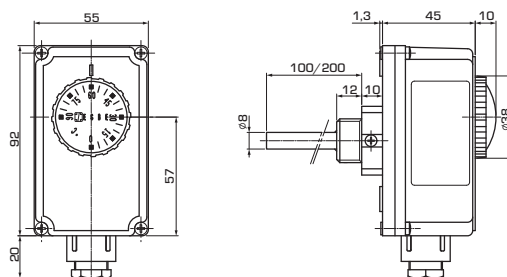

Art. No.	Reference	Immersion sleeve [mm]	Immersion pocket Connection	Weight [kg]	Note
86901100	TIA122	100	G 1/2"	0,23	
86901200		200		0,25	



## IMMERSION DOUBLE THERMOSTAT Series TIB100

- **Two in One solution - Temp. safety limiter and temperature regulation**
- **90-110°C Setable temperature of Safety limiter**
- **0-90°C setable temperature of Temperature regulator**

The ESBE TIB100 is a combination of temperature safety limiter (STB) and temperature regulator (TR), consisting of temperature probes connected to switches.

### TECHNICAL DATA

Contacts rating adjustable thermostat: \_\_\_\_\_ C1 10(2,5)A /250V~  
 \_\_\_\_\_ C2 6(2,5)A NC/250V~  
 Contacts rating limiter thermostat: \_\_\_\_\_ N-C 10(2,5)A/250V~  
 Enclosure rating: \_\_\_\_\_ IP40  
 Control range: \_\_\_\_\_ 0 - 90 ± 3°C  
 Limit temperature: \_\_\_\_\_ (90 -110°C) Fixed 110°C +0/-6°C  
 Fail safe: \_\_\_\_\_ Yes  
 Maximum ambient temperature: \_\_\_\_\_ 80°C  
 Maximum bulb temperature: \_\_\_\_\_ 125°C  
 Temperature differential, STB: \_\_\_\_\_ ΔT 15 ± 8K  
 TR: \_\_\_\_\_ ΔT 4 ± 1K

Material  
 Cover: \_\_\_\_\_ Plastic  
 Sensor: \_\_\_\_\_ Copper

CE LVD 2014/35/EU - RoHS 2011/65/EU  
 PED 2014/68/EU, Annex III - Module H1

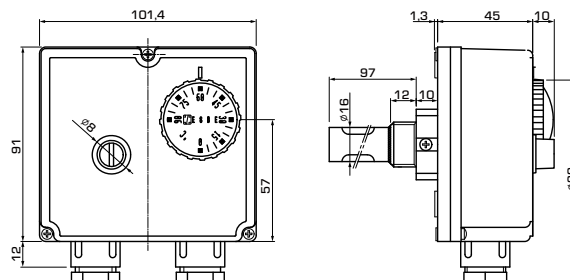

Art. No.	Reference	Immersion sleeve [mm]	Immersion pocket Connection	Weight [kg]	Note
86902100	TIB121	100	G 1/2"	0,38	



## CONTACT THERMOSTAT Series TSA100

- Internal and External setting
- On/Off principle
- Easy installation

The ESBE TSA100 is a ON/OFF thermostat, consisting of temperature probe connected to a switch. The switch can be used to control ON/OFF, based on the temperature measurement, any electrical device e.g. pump, boiler, etc.

### TECHNICAL DATA

Contacts rating adjustable thermostat: \_\_\_\_\_ see table  
 Enclosure rating: \_\_\_\_\_ see table  
 Control range: \_\_\_\_\_ see table  
 Limit temperature: \_\_\_\_\_ 125°C (Fixed 60°C TSA121)  
 Maximum ambient temperature: \_\_\_\_\_ 80°C (55°C TSA121)  
 Temperature differential: \_\_\_\_\_  $\Delta T 8 \pm 2K$

Material  
 Cover: \_\_\_\_\_ Plastic  
 Sensor: \_\_\_\_\_ Copper

CE LVD 2014/35/EU - RoHS 2011/65/EU

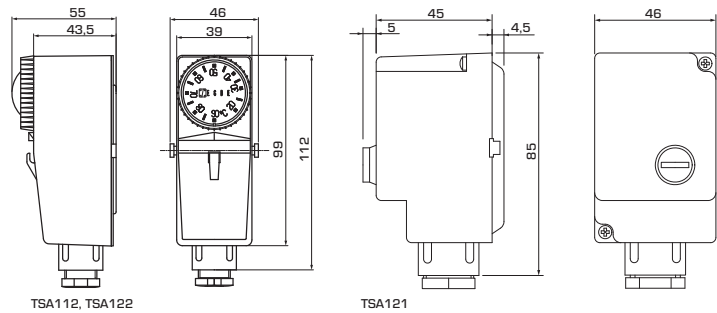

Art. No.	Reference	Control range	Contacts rating	Enclosure rating	Weight [kg]	Note
86900100	TSA121	40 - 70°C $\pm 5^\circ C$	[C-2] 10A	IP40	0,18	Internal setting
86900200	TSA122	20 - 90°C	[C-1] 10A/ [C-2] 6A 250V AC	IP30	0,15	External setting
86900300	TSA112	20 - 90°C	[C-1] 10A/ [C-2] 6A 250V AC	IP30	0,14	Internal setting



# INDEX, ART.NO. ORDER

Art.No.	Page	Art.No.	Page	Art.No.	Page	Art.No.	Page	Art.No.	Page	Art.No.	Page
<b>1100</b>		11660400	46	12642200	86	18004200	95	21302200	150	31102600	127
11005200	51	11660500	46	12660100	80	18004300	95	21302300	150	31102700	127
11005300	51	11660800	46	12661400	80	18004400	95	21302400	150	31102800	127
11100100	47	11660900	46	12662200	80	18004500	95	21302500	150	31102900	127
11100200	47	11661000	46	12662500	80	<b>2100</b>		21302600	150	31103200	127
11100300	47	11661100	46	12682200	84	21000400	144	21400100	149	31103900	127
11100400	47	11661200	46	12682500	84	21000500	144	21400200	149	31104700	web only
11100600	47	11661500	46	12720100	76	21000600	144	21400300	149	31104900	128
11100800	47	11661600	46	12720200	76	21000700	144	21400400	149	31105000	129
11101000	47	11661700	46	12720500	76	21000800	144	21400500	149	31105100	129
11101200	47	11662000	46	12723100	85	21001200	144	21400600	149	31105200	129
11101400	47	11662100	46	12723500	85	21001300	144	21400700	149	31106100	129
11101600	47	11662200	46	12724100	78	21001400	144	21400800	149	31150200	130
11101700	47	11662300	46	12725100	79	21001500	144	21400900	149	31150300	130
11101800	47	11662400	46	12742100	77	21001600	144	21401000	149	31150700	130
11101900	47	11700100	44	12742200	77	21150100	145	21401100	149	31150900	130
11102000	47	11700200	44	12742500	77	21150200	145	21401200	149	31151000	131
11102100	47	11700300	44	12820100	81	21150300	145	21401300	149	31151100	131
11102200	47	11700600	44	12820300	81	21150400	145	21401400	149	31151200	131
11102300	47	11700700	44	12820500	81	21150500	145	21401500	149	31151400	131
11102400	47	11700800	44	12824100	83	21150600	145	21401600	149	31152100	130
11300400	52	11701100	44	12842100	82	21150700	145	21401700	149	31200100	134
11300600	52	11701200	44	12842500	82	21150800	145	21500100	97	31200200	134
11300700	52	11701300	44	<b>1300</b>		21150900	145	21500200	97	31200300	134
11300900	52	11701400	44	13020600	74	21151000	145	21500300	97	31200400	134
11301000	52	11701500	44	13020700	74	21151100	145	21500400	97	31350500	web only
11350100	50	11720100	49	13020800	74	21151200	145	21500500	97	31400100	122
11350200	50	11720200	49	13022300	74	21151300	145	21500600	97	31400200	122
11350500	50	11720300	49	13022400	74	21151400	145	21500700	97	31400300	122
11350800	50	<b>1200</b>		13023500	114	21151500	145	21500800	97	31400400	122
11351100	50	12050200	70	13023600	114	21151600	145	21501100	97	31400500	122
11351200	50	12050400	web only	13023700	114	21200100	146	21501200	97	31405010	122
11600100	41	12050600	70	13040100	90	21200200	146	21501300	97	31502000	123
11600200	41	12050700	70	13041000	90	21200300	146	21501400	97	31502100	123
11600300	41	12050900	web only	13041100	90	21200400	146	21501500	97	31502200	123
11600400	41	12051100	70	13900100	48	21200500	146	21501600	97	31502300	123
11600500	41	12051300	70	13900200	48	21200600	146	21501700	97	31502400	123
11600600	41	12051500	web only	13900300	48	21200700	146	21501800	97	31502500	123
11600700	41	12051700	70	13900400	48	21200800	146	21502100	97	31502600	123
11600800	41	12051800	70	13900500	48	21200900	147	21502200	97	31521000	124
11600900	41	12051900	70	13900600	48	21201000	147	21502300	97	31521100	124
11601000	41	12052000	70	13900700	48	21201100	147	21502400	97	31521200	web only
11601100	41	12052100	70	13900800	48	21201200	147	21502500	97	31521300	124
11601200	41	12052200	70	13900900	48	21201300	147	21502600	97	31521400	124
11601500	42	12052300	70	13901000	48	21201400	147	21502700	97	31521500	web only
11601600	42	12052400	70	13901100	48	21201500	147	21502800	97	31523000	124
11601700	42	12052500	71	13905100	60, 88	21201600	147	<b>2200</b>		31523100	124
11601800	42	12052600	71	13905200	60, 88	21201800	147	22050100	164	31523200	web only
11601900	42	12053300	70	13906000	48	21220200	147	22200100	162	31523300	124
11602000	42	12100100	68	13906100	48	21220300	147	22200200	162	31523400	124
11602100	42	12100200	68	13906200	48	21220400	147	22200300	162	31523500	web only
11602200	42	12100300	68	13906300	48	21220500	147	22200400	162	31525000	123
11602300	42	12100400	68	13906400	48	21221100	147	22201100	162	31580100	119
11602400	42	12100500	68	<b>1600</b>		21221200	147	22201200	162	31580200	119
11602500	42	12100600	web only	16000500	88	21221300	147	22201300	162	31600100	119
11602600	42	12100700	68	16000600	88	21221400	147	22201400	162	31600200	119
11602900	42	12100800	68	16000700	88	21221500	147	22220100	163	31600300	119
11603000	42	12100900	web only	16000800	88	21250100	148	22221100	163	31600400	web only
11603100	42	12101000	web only	16000900	88	21250200	148	22500100	98	31620100	127
11603400	41	12101100	68	16001000	88	21250300	148	22500200	98	31620200	127
11603500	42	12101200	68	16001100	88	21250400	148	22500300	98	31620300	127
11603600	41	12101300	68	16051300	89	21250500	148	<b>2600</b>		31620400	127
11603700	42	12101400	68	16051400	89	21250600	148	26000100	165	31620500	127
11603800	42	12101500	68	16051500	89	21250700	148	26000200	165	31620600	127
11603900	42	12101600	68	16051700	89	21250800	148	26000400	165	31620700	128
11604000	42	12101700	68	16052500	89	21250900	148	26000500	165	31620800	128
11604100	42	12101800	68	16052600	89	21251000	148	26000700	165	31620900	128
11604400	42	12101900	68	16053300	89	21251100	148	26000800	165	31621000	128
11604500	42	12102000	web only	16053400	89	21251200	148	26000900	web only	31621100	128
11604600	42	12120100	69	16053600	89	21251300	148	26001000	165	31621200	128
11620100	45	12120200	69	16053700	89	21251400	148	26001100	165	31621300	web only
11620200	45	12120300	web only	16053900	89	21251500	148	26001200	165	31621400	128
11620300	45	12120400	web only	16103800	53	21251600	148	26100700	151	31621500	web only
11620600	45	12120500	web only	16103900	53	21251700	148	26100800	151	31621600	128
11620700	45	12120600	69	16104000	53	21251800	148	26100900	151	31621700	128
11620800	45	12120700	69	16104100	53	21251900	148	26101000	151	31640100	130
11621100	45	12120800	69	16200700	74	21252000	148	26101100	151	31640200	130
11621200	45	12120900	69	<b>1700</b>		21252100	148	26101200	151	31640300	130
11621300	45	12121000	69	17050700	90	21252200	148	26101300	151	31640400	130
11621400	45	12121100	69	17050800	90	21252300	148	26101400	151	31640600	130
11621500	45	12121200	69	17050900	90	21252400	148	26101500	151	31641000	130
11621600	45	12200100	72	17051000	90	21300100	150	26101600	151	31641100	130
11621700	45	12201100	72	17051100	90	21300200	150	26101700	151	31641200	130
11621800	web only	12220100	72	17053100	90	21300300	150	26101800	151	31641300	130
11621900	web only	12220200	72	17056000	90	21300400	150	26200700	165	31641500	130
11640100	43	12240100	73	17056100	90	21300500	150	26201100	165	31660100	129

# INDEX, ART.NO. ORDER

Art.No.	Page	Art.No.	Page	Art.No.	Page	Art.No.	Page	Art.No.	Page	Art.No.	Page
31680300	131	43102600	115	55004500	102	61241100	16				
31680400	131	43102700	115	55004600	102	<b>6400</b>					
31681000	131	43102800	115	55004700	102	64000100	37				
31681100	131	43122100	118	55004800	102	64020100	37				
31681200	131	43122200	118	55004900	102	<b>6600</b>					
31681300	131	43122300	118	55005000	102	66000100	19				
31700100	134	43122400	118	55005100	102	66000200	19				
31700400	134	43123100	116	55007100	102	66000300	19				
31702100	134	43123200	116	55007200	102	66000400	19				
31702200	134	43123300	116	55007300	102	66000500	19				
31702300	134	43123400	116	55007400	102	66000600	19				
31702400	134	<b>4600</b>		55007500	102	<b>8600</b>					
31702500	134	46050100	web only	55007600	102	86900100	171				
31702600	134	46050200	web only	55007700	102	86900200	171				
31720100	132	46050300	114	55007800	102	86900300	171				
31720200	132	46050400	114	55007900	102	86901100	170				
31720300	132	<b>5100</b>		55008000	102	86901200	170				
31720400	132	51000100	105	<b>5600</b>		86902100	170				
31720500	132	51000200	105	56001100	106	<b>9800</b>					
31720600	web only	51000300	105	56001200	106	98100690	74				
31720700	web only	51000400	web only	56001300	106						
31720800	web only	51000500	web only	56001500	106						
31720900	web only	51000800	105	56020100	107						
31721000	web only	51000900	105	56020200	107						
31721100	web only	51001000	105	56020300	107						
31721200	web only	51001100	web only	<b>5700</b>							
31740100	133	51001200	web only	57000100	108						
31740200	133	51001500	105	57000200	108						
31740300	133	51001600	105	57000300	108						
31740400	133	51001700	105	57000400	108						
31740500	133	51001800	web only	57000500	108						
31740600	133	51001900	web only	57000600	108, 124						
31740700	133	51002200	105	57000700	108						
31740800	web only	51002300	105	57020100	108						
31740900	web only	51002400	105	57020200	108						
31741000	web only	51002500	web only	57020300	108						
<b>3600</b>		51002600	web only	57020400	108						
36020100	167	51002900	105	57020500	108						
36020200	web only	51003000	105	57020600	108						
36020300	167	51003100	105	57020700	108						
36020400	167	51003200	web only	57020800	108						
36020500	167	51003300	web only	<b>6100</b>							
36020800	108	51020100	103	61000100	12						
36022000	web only	51020200	103	61000200	12						
36022300	web only	51020300	103	61000300	12						
36022500	web only	51020400	103	61000400	12						
36022600	web only	51020500	web only	61003100	12						
36022700	web only	51020600	103	61020100	13						
36022800	web only	51020700	103	61020200	13						
36023500	168	51020800	103	61020300	13						
36025000	168	51020900	103	61020400	13						
36025100	web only	51021000	web only	61023100	13						
36027000	web only	51021100	103	61040100	11						
36100100	169	51021200	103	61040200	10						
36200100	168	51021500	104	61040300	9						
36300100	169	51021600	104	61040400	11						
36401000	167	51021700	104	61040500	11						
36401100	167	51021800	104	61040600	11						
36500100	169	51021900	web only	61040700	10						
36500400	169	51022000	104	61040800	9						
36551700	53	51022100	104	61040900	10						
36551800	53	51022200	104	61041000	9						
36551900	53	51022300	104	61041100	10						
36552000	53	51022400	web only	61041200	9						
36552100	53	51022500	104	61041300	10						
36552200	136	51022600	104	61041400	10						
36552300	136	51025500	web only	61041500	10						
36552400	136	51025600	103	61041600	10						
36552500	136	51025700	103	61043100	11						
36552900	136	51025800	103	61043200	11						
<b>4300</b>		51025900	web only	61043300	11						
43060200	113	51026000	103	61043400	11						
43060600	113	51026100	103	61043500	11						
43060700	113	51026200	103	61060100	15						
43060800	113	51026300	web only	61060200	14						
43061200	113	51026500	103	61060300	15						
43061400	113	51026600	103	61060400	14						
43061600	113	51026700	103	61060500	15						
43080100	114	51026800	web only	61060600	14						
43080300	114	51026900	web only	61060700	15						
43080400	114	51027000	103	61060800	14						
43080700	114	51027100	103	61120100	31						
43080800	114	51027200	103	61120200	31						
43100100	118	51027300	web only	61120300	31						
43100200	118	51027400	web only	61120400	31						
43100300	118	51027500	web only	61120500	31						
43100400	118	51027600	web only	61120600	31						
43100500	118	51027700	web only	61140100	30						
43100600	118	51027800	103	61140200	29						
43100700	117	51060100	104	61140300	30						
43100800	117	51060200	104	61140400	29						
43100900	117	51060300	104	61140500	30						
43101000	117	51060400	104	61140600	29						
43101100	117	51060500	104	61140700	30						
43101200	117	51060600	104	61140800	29						
43101300	117	51500100	104	61160100	32						
43101400	117	<b>5500</b>		61160200	32						
43102100	115	55004000	102	61160300	32						
43102200	115	55004100	102	61160400	32						
43102300	115	55004200	102	61200100	17						
43102400	115	55004300	102	61220100	18						
43102500	115	55004400	102	61240100	16						

# INDEX, SERIES ORDER

Series	Page	Series	Page	Series	Page	Series	Page	Series	Page
<b>ALA</b>		<b>CRC</b>		<b>TEA</b>		<b>VRI</b>		<b>90C</b>	
ALA821	165	CRC111	81, 90	TEA111	94	VRI111	53	90C-1A-90	87
ALA823	165	CRC113	81	TEA114	94	<b>VSx</b>		90C-1B-90	87
ALA824	165	CRC115	81	TEA117	94	VS8132	167	90C-1C-90	87
ALA826	165	CRC121	82	TEA119	94	VS8232	168	90C-3B-90	87
ALA827	165	CRC125	82	TEA128	94	VS8311	168	90C-3C-90	87
<b>ALB</b>		CRC141	83	<b>TFC</b>		VST212	108	<b>900</b>	
ALB144	164	CRC911	90	TFC111	95	<b>VTA</b>		900	89
ALB841	165	CRC912	90	TFC112	95	VTA312	135	900-270	89
<b>ALF</b>		<b>CRD</b>		TFC121	95	VTA313	135	900A	89
ALF131	162	CRD122	84	TFC122	95	VTA321	127	900B	89
ALF134	162	CRD125	84	TFC139	95	VTA322	127	900C	89
ALF261	162	<b>CRS</b>		<b>Tlx</b>		VTA323	127	900CK	89
ALF264	162	CRS131	85	TIA122	170	VTA332	130	900F	89
ALF361	162	CRS135	85	TIB121	170	VTA333	130	900K	89
ALF364	162	CRS211	90	<b>TMA</b>		VTA351	128	900L	89
ALF461	162	CRS213	90	TMA115	93	VTA352	129		
ALF464	162	CRS214	90	TMA116	93	VTA353	129		
ALF801	165	CRS215	90	TMA117	93	VTA362	131		
ALF802	165	CRS231	90	<b>TPx</b>		VTA363	131		
<b>ALG</b>		<b>CTF</b>		TPD112	92	VTA372	134		
ALG434	98	CTF151	107	TPD214	93	VTA377	134		
ALG436	98	CTF271	107	TPE214	93	VTA378	134		
ALG438	98	CTF851	107	TPH114	92	VTA522	127, 128		
<b>ALH</b>		<b>CUA</b>		TPW114	92	VTA523	128		
ALH134	163	CUA111	86	TPW214	93	VTA532	130		
ALH234	163	CUA122	86	<b>TSA</b>		VTA533	130		
<b>ALZ</b>		<b>FSK</b>		TSA112	171	VTA552	129		
ALZ801	114	FSK101	37	TSA121	171	VTA562	131		
<b>ARA</b>		FSK803	37	TSA122	171	VTA572	134		
ARA635	69	<b>GBx</b>		<b>UTC</b>		VTA577	134		
ARA636	69	GBA111	15	UTC317	106	VTA578	134		
ARA637	69	GBA112	15	<b>VBF</b>		<b>VTC</b>			
ARA639	69	GBC211	14	VBF125	48	VTC311	105		
ARA641	68	GBC212	14	VBF801	88	VTC312	105		
ARA642	68	<b>GDx</b>		VBF802	88	VTC317	105		
ARA643	68	GDA111	12	VBF806	48	VTC318	105		
ARA645	69, 114	GDA112	12	<b>VCA</b>		VTC412	104		
ARA646	69	GDA311	12	VCA100	169	VTC422	104		
ARA647	69	GDF111	17	<b>VDA</b>		VTC511	103		
ARA651	68	<b>GFx</b>		VDA102	168	VTC512	104		
ARA652	68	GFA111	13	<b>VFA</b>		VTC531	103		
ARA653	68	GFA112	13	VFA103	169	VTC931	108, 124		
ARA654	68	GFA311	13	<b>VLA</b>		VTC951	108		
ARA655	69	FFF111	18	VLA121	145	VTC952	108		
ARA656	69	<b>GMA</b>		VLA131	145	VTC953	108		
ARA658	69	GMA121	19	VLA325	146	<b>VTD</b>			
ARA659	69	GMA131	19	VLA335	147	VTD322	119		
ARA661	68, 74	GMA221	19	VLA821	165	VTD582	119		
ARA662	68	GMA231	19	<b>VLB</b>		<b>VTR</b>			
ARA663	68	GMA321	19	VLB325	147	VTR322	122		
ARA664	68	GMA331	19	VLB335	147	VTR522	122		
ARA671	68	<b>GRx</b>		VLB891	165	VTR801	122		
ARA672	68	GRA111	11	<b>VLC</b>		<b>VTS</b>			
ARA673	68	GRA112	11	VLC125	150	VTS522	132		
ARA691	68	GRA131	11	VLC225	150	VTS552	133		
ARA693	68	GRA132	11	<b>VLE</b>		<b>VVA</b>			
ARA803	88	GRA311	11	VLE122	148	VVA102	169		
ARA805	88	GRC111	10	VLE132	148	<b>VZx</b>			
ARA806	88	GRC112	10	VLE222	148	VZC152	113		
ARA807	88	GRC141	10	VLE325	149	VZC161	113		
ARA808	88	GRC142	10	<b>VLF</b>		VZC162	113		
ARA809	88	GRC211	9	VLF125	144	VZC263	113		
ARA810	88	GRC212	9	VLF135	144	VZD161	114		
<b>ARC</b>		GRF111	16	<b>VLG</b>		VZD162	114		
ARC361	72	GRF121	16	VLG122	97	VZD263	114		
ARC363	72	<b>GSx</b>		VLG132	97	<b>ZRS</b>			
ARC368	72	GSA111	30	VLG142	97	ZRS224	118		
ARC369	72	GSA112	30	<b>VMx</b>		ZRS234	116		
<b>ARD</b>		GSC111	29	VMA213	167	3F	47		
ARD155	73	GSC112	29	VMB423	123	3HG	50		
ARD157	73	GSC121	32	VMC322	124	4F	47		
ARD169	73	GSC122	32	VMC522	124	4H	50		
ARD255	73	GST131	31	VMD322	123	5MG	51		
ARD257	73	GST132	31	<b>VRB</b>		<b>90</b>			
ARD269	73	GST141	31	VRB141	46, 90	91	70		
<b>ATA</b>		GST142	31	VRB142	46	92	70		
ATA212	106	<b>Kxx</b>		VRB143	46	92M	70		
ATA222	106	KCD313	136	<b>VRG</b>		92P	71		
<b>CRA</b>		KSB114	151	VRG131	41, 90	92P2	71		
CRA111	76, 90	KTB112	151	VRG132	42	92P4	71		
CRA112	76	KTD112	53	VRG133	42	92-2	70		
CRA115	76	KTD212	136	VRG138	42	93	70		
CRA121	77	KTD213	136	VRG139	42	94	70		
CRA122	77	<b>LTC</b>		VRG141	43	94M	70		
CRA125	77	LTC261	102	VRG142	43	95	70		
CRA141	78	LTC271	102	VRG231	45	95M	70		
CRA151	79	<b>MBA</b>		VRG232	45, 114	95-2	70		
CRA911	90	MBA121	118	VRG233	45	92-2M	70		
<b>CRB</b>		MBA122	117	VRG331	44	95-270M	70		
CRB111	80	MBA124	118	VRG332	44	96	70		
CRB114	80	MBA132	115	VRG338	44	96M	70		
CRB122	80	MBA135	115	VRG801	89	97	71		
CRB125	80	MBA136	115	VRG804	89	98	71		
		<b>T</b>		<b>VRH</b>					
		T	52	VRH139	49				
		TM	52						

# CERTIFICATES & PRODUCT DECLARATIONS

## ESBE PRODUCTS

We work hard to secure that our technical data in product documentation is correct. This is done partly through validation in our own advanced lab. In addition, if it is needed, we make external tests for our products at authorized test institutes. You will find the certificates and product declarations at our website. If you happen to miss something, don't hesitate to contact your usual ESBE contact.



**Valves, Re. PED 2014/68/EU**

Pressure Equipment in conformity with 2014/68/EU, article 4.3 (sound engineering practice). According to the directive the equipment shall not carry any CE-mark.

**Actuators and controllers, Re. LVD 2014/35/EU and EMC 2014/30/EU**

All our products, which are concerned by these directives, conform to the same. Those products carry accordingly a CE-sign.



**Disposal of valves**

The products must not be disposed of together with domestic waste, but should be treated as metal scrap. Local and currently valid legislation must be observed.

**Disposal of actuators and regulators**

The device must not be disposed of together with domestic waste. This applies in particular to the printed circuit card. Legislation may demand special handling of certain components, or it may be desirable from an ecological point of view. Local and currently valid legislation must be observed.



Declarations of conformity



GOST, PZH product certificates



- From fall 2014 all ESBE products containing brass which are recommended for use in drinking water are manufactured out of dezincification resistant brass DZR which are according to the "Hygienic copper alloy composition list HCACL" this includes the 4MS-Composition List of accepted metallic materials and the German UBA List.



ESBE AB is quality certified according to ISO9001 since 1995 and environmentally certified according to ISO14001 since 1999.





# MADE IN SWEDEN WITH THE WORLD IN MIND

**Five sales companies and partners in over 30 countries gives ESBE a large market presence throughout Europe.** The base is still in Reftete in the county of Småland, the tiny village in southern Sweden where it all began. The Swedish plant with head office, R&D department and factory is state-of-the-art and products are distributed all over Europe.

To meet the demands on high delivery reliability – and because our product portfolio is constantly growing in size as well as brand awareness – our products are delivered to central and southern Europe via ESBE's distribution centre in Munich.

**Find country specific contacts info >> [esbe.eu](http://esbe.eu)**

## ESBE COMPANIES

### Sweden • Head office and factory

ESBE AB  
Tel: +46 (0)371 - 570 000  
[www.esbe.se](http://www.esbe.se)

### Poland

ESBE Hydronic Systems Sp. z o.o.  
Tel: +48 61 85 10 728  
[www.esbe.pl](http://www.esbe.pl)

### Germany, Austria

ESBE GmbH  
Tel: +49 (0)8131 99 6670  
[www.esbe.de](http://www.esbe.de)

### France

ESBE S.a.r.l.  
Tel: +33 (0) 1 47 90 07 26  
[www.esbe.fr](http://www.esbe.fr)

### Italy

ESBE S.r.l.  
Tel: +39 059 280094  
[www.esbe-italia.it](http://www.esbe-italia.it)



**NO.1 IN HYDRONIC SYSTEM CONTROL**